

ZEXEL - TEST VALUES
Injection pumps

BOSCH No.	:	9 400 610 188	1/6
ZEXEL No.	:	101401-1123	
Date	:	31.10.1992	[3]
Company	:	MITSUBISHI	
Engine	:	4D31T / ME016321	

IP-Type number	:	101040-9280 / PES4A
Governor type number	:	105921-1713/EP/RLD-E

TEST PREREQUISITES

Test oil	:	ISO-4113
Test oil inlet temperature °C	:	40.00...45.00
Inlet pressure bar	:	1.6
Test nozzle holder combination	:	1 688 901 013
Opening pressure bar	:	175
Test pressure line	:	
Inner x Outer Dia - Length mm	:	2.00 x 6.00 x 600

PORT CLOSING

Prestroke	mm	:	3.6 ± 0.05
Rod position	mm	:	-
Port closing mark	Cyl. No.	:	-
Cam sequence		:	1 - 3 - 4 - 2

Port closing mark	Cyl. No.	:	-
Port closing difference	°NW	:	0-90-180-270

Tolerance	+ - °C	:	0.50 (0.75)
-----------	--------	---	-------------

A1

ZEXEL - Test values
Injection pumps



Injection Quantity :

Adjusting Point	Rack Position (mm)	P. Speed (r.p.m)	Injection Q'ty (cm ³ /1000 str.)	Difference (%)	Fixed	Remarks
	10.6	1000	55.1 ± 1.0	± 2.5	Rack	Basic
H	approx. 9.5	325	10.0 ± 1.3	± 10.0	Rack	
A	R ₁ (10.6)	1000	55.1 ± 1.0	-	Lever	Basic Boost pressure kPa (mmHg) above 42.6 (above 320)
B	R ₁ +0.3	1750	71.0 ± 2.0	-	Lever	
C	R ₂ (R ₁ -0.4)	700	(39.9 ± 2.0)	-	Lever	
D	R ₂ +0.4	500	(35.7 ± 2.0)	-	Lever	
I	-	100	69.5 ± 2.5	-	Lever	Control rack limit

Timing Advance Specification : EP/SCDM
105676-0250

Pump Speed (r.p.m)							
Advance Angle (deg.)							

A2

ZEXEL - Test values
Injection pumps



A3

ZEXEL - Test values
Injection pumps



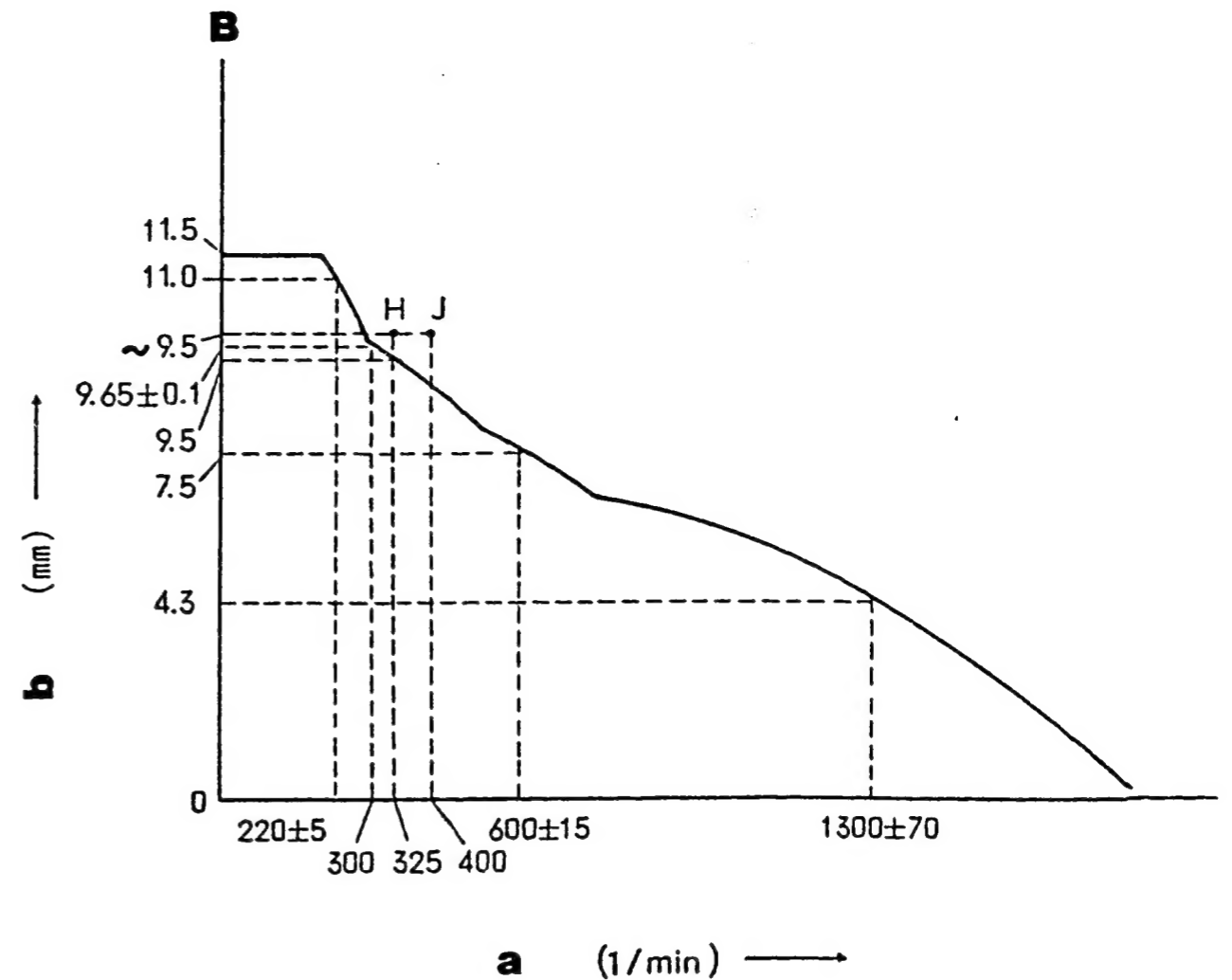
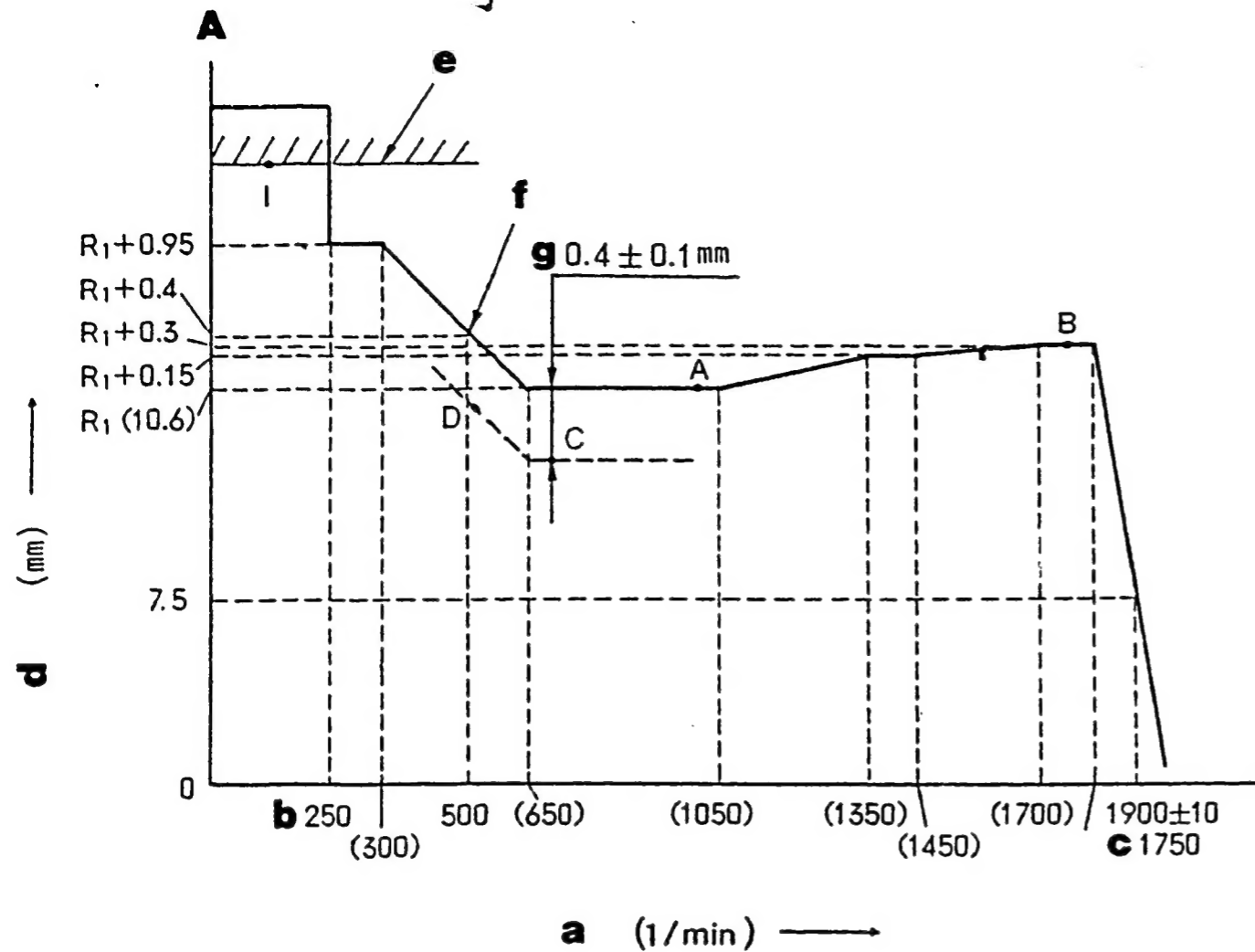

Figure 1

A = Full-Load Adjustment

- a = Pump speed
- b = Below
- c = Above
- d = Control rack position
- e = Control rack limit
- f = Torque cam adjustment
- g = Boost compensator stroke:

GOVERNOR ADJUSTMENT

101401-1123 2/6

B = Idle Adjustment

- a = Pump speed
- b = Control rack position

A4

ZEXEL - Test values

Injection pumps



A5

ZEXEL - Test values

Injection pumps



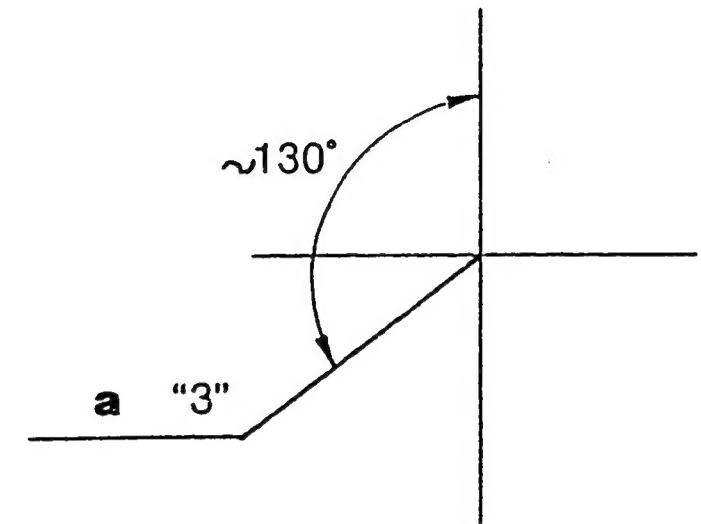
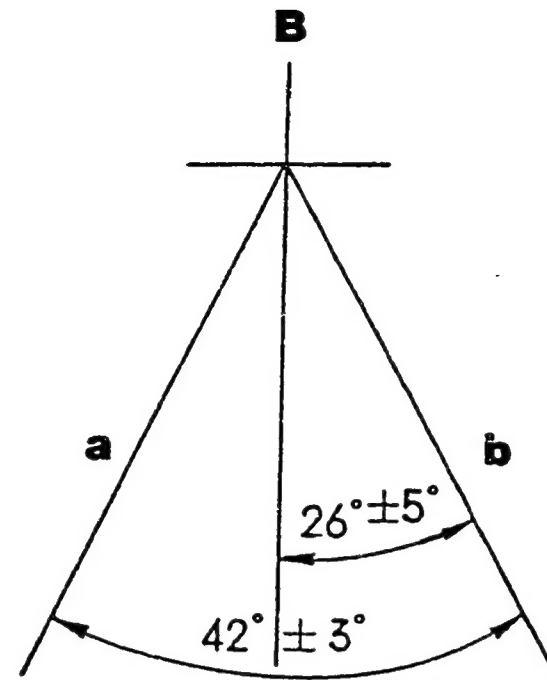
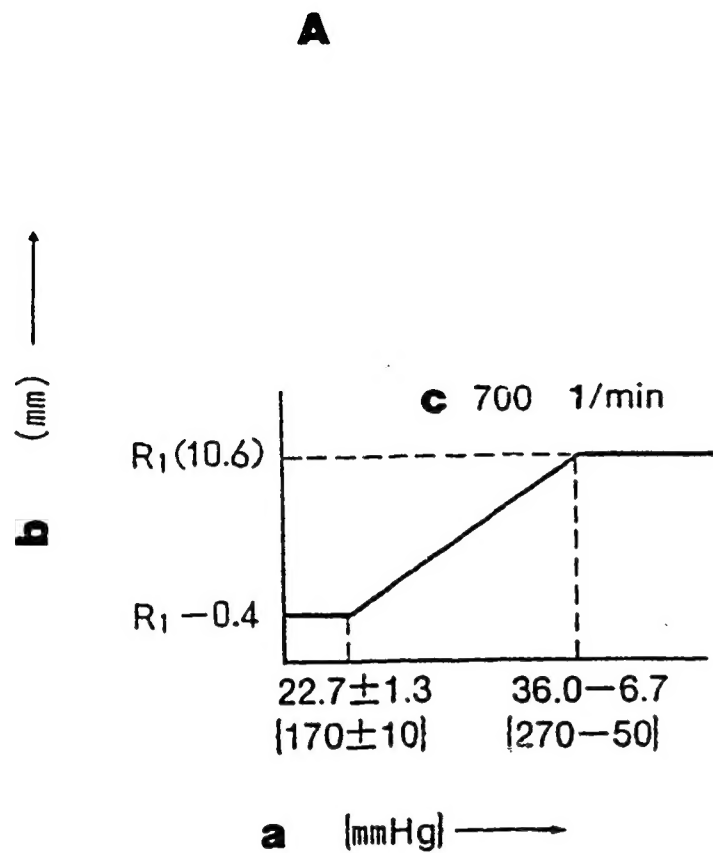

Figure 2

101401-1123 3/6

A = Boost Compensator Adjustment

a = Boost pressure
 b = Control rack position
 c = Perform at:

B = Speed Control Lever Angle

a = Full-speed
 b = Idling

■ **TIMING SETTING**

At No. 1 plunger's beginning of injection position B.T.D.C: 11°

a = Gear mark

A6

ZEXEL - Test values
 Injection pumps



A7

ZEXEL - Test values
 Injection pumps



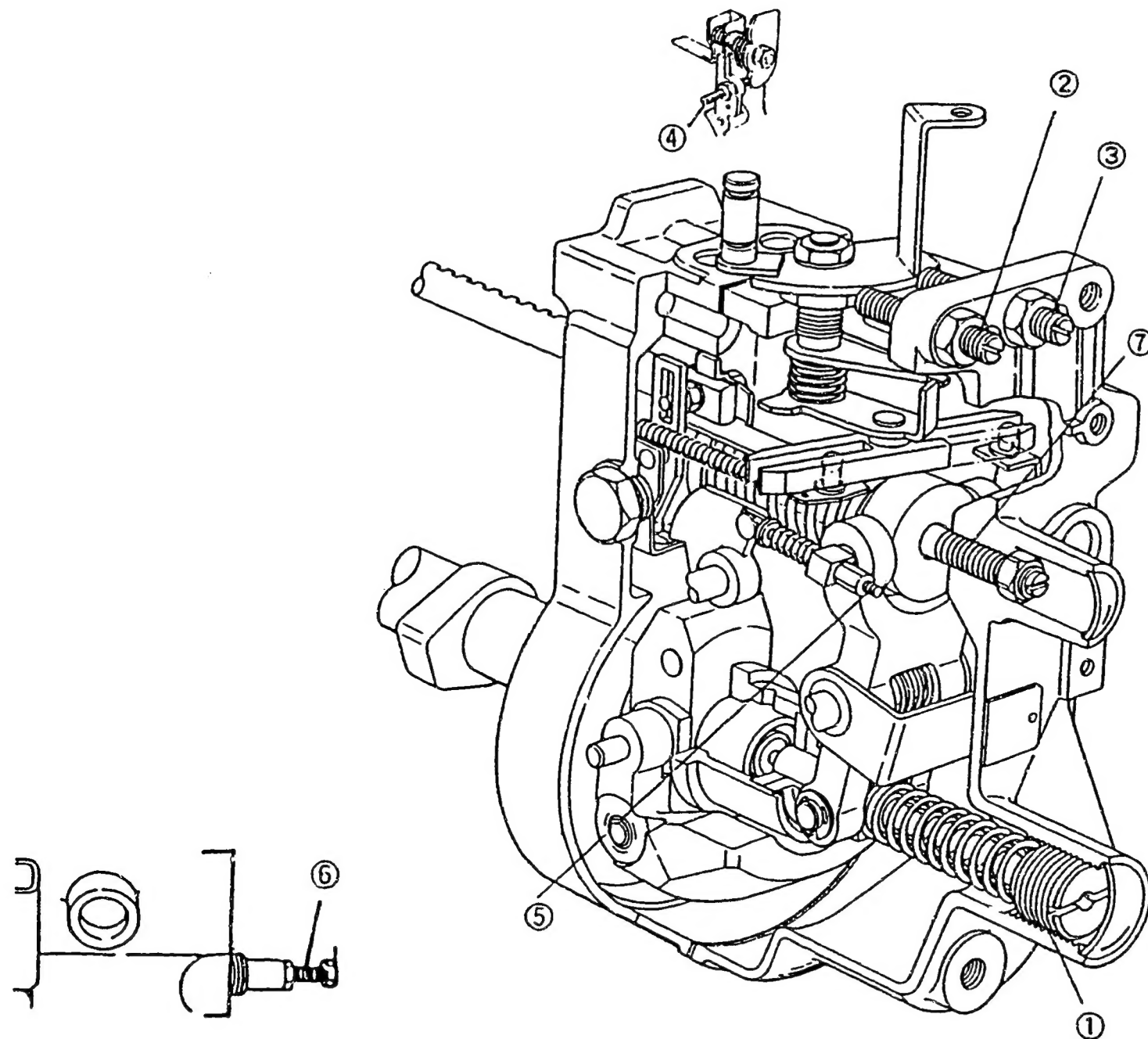

Figure 3

101401-1123 4/6

- 1 = Spring capsule
- 2 = Screw
- 3 = Screw
- 4 = Screw

- 5 = Screw
- 6 = Screw
- 7 = Governor shaft



	Pump Speed (rpm)	Rack Position (mm)	Remarks
Idling Lever Position Temporary Setting	100	11.5	• Adjust using screw (2)
Idling Position Setting	220 ± 5 325	11.0 9.5	• Adjust using spring capsule (1) • Adjust using screw (2)
Governor Spring Contact Adjustment	600 ± 15 1300 ± 70	7.5 4.3	• Adjust the governor shaft position • Confirm
Setting the Idling Lever Position	325 -	approx. 9.5 -	• Adjust using screw (2) • Confirm the control lever angle (21° - 31°)

	Pump Speed (r.p.m)	Rack Position (mm)	Remarks
Full Speed Lever Position Temporary Setting	1750	R_1 (10.6)	• Adjust using screw (3)
Full Load Position Adjustment	1000	R_1 (10.6)	• Adjust using screw (4)
Torque Cam Position Adjustment	500 approx. 300 650 1050 1350 1450 1700	$R_1 + 0.4$ $R_1 + 0.95$ R_1 (10.6) R_1 (10.6) $R_1 + 0.15$ $R_1 + 0.15$ $R_1 + 0.3$	• Adjust using screw (5) • Confirm • Confirm • Confirm • Confirm • Confirm • Confirm
	Confirm injection quantity at point A		
Maximum Speed Control Adjustment	above 1750 1900 ± 10 -	$R_1 + 0.3$ 7.5 -	• Adjust using screw (3) • Confirm • After adjustment confirm that the control lever angle is $39^\circ - 45^\circ$
Confirming Excess Fuel Limit for Engine Starting	400 0	approx. 9.5 11.5	• Set the control lever at point J • Confirm • Move the control lever to the "full-speed" position and then confirm the control rack position
Confirm the Black Smoke Limit	Fix the control lever at point H. Then operate the pump at 250 rpm. Confirm that the control rack does not move beyond $R_1 + 0.95$ mm. When the control lever is moved to the "full-speed" position again increase the pump speed and confirm that the control rack starts to move from a pump speed of 300 rpm.		
Rack Limiter Adjustment	Fix the control lever in the full speed position, and fix the control rack using the screw when the pump speed reaches 100 rpm and the fuel injection quantity obtained is 62 - 72 cm ³ /1000st.		
	Measure the depth of the control rack cap. Then adjust screw (6) so that it equals the depth of the rack cap and install the rack cap. Confirm injection quantities.		



	Boost pressure kPa (mmHg)	Rack position (mm)	Remarks
Boost Compensator Spring Adjustment	0	10.6 → 10.2	• Adjust using screw (8)
Setting the Boost Compensator Spring Force	22.7 ± 1.3 (170 ± 10)	R ₁ -0.4	• Adjust using screw (7)
	36.0 -6.7 (270 -50)	R ₁ (10.6)	• Confirm the boost compensator stroke is 0.4 ± 0.1 mm

■ BOOST COMPENSATOR ADJUSTMENT

Maintain the pump speed at 700 rpm and fix the control lever in the full load position.

In this condition, use calipers to measure the dimension „L” of the pushrod from the end face of the spacer.

(Inspection: 23.5 to 24.5 mm)

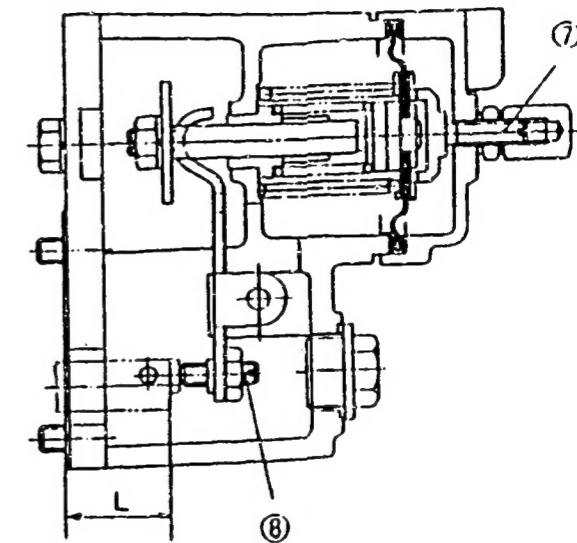

Figure 4

7 = Screw

8 = Screw

A14

ZEXEL - Test values
Injection pumps



A15

ZEXEL - Test values
Injection pumps



ZEXEL - TEST VALUES
Injection pumps

BOSCH No.	:	9 400 610 189	1/6
ZEXEL No.	:	101401-1223	
Date	:	31.10.1992	[3]
Company	:	MITSUBISHI	
Engine	:	4D31T / ME016740	

IP-Type number	:	101040-9530 / PES4A
Governor type number	:	105921-1713/EP/RLD-E

TEST PREREQUISITES

Test oil	:	ISO-4113
Test oil inlet temperature °C	:	40.00...45.00
Inlet pressure bar	:	1.6
Test nozzle holder combination	:	1 688 901 013
Opening pressure bar	:	175
Test pressure line	:	
Inner x Outer Dia - Length mm	:	2.00 x 6.00 x 600

PORT CLOSING

Prestroke	mm	:	3.6 ± 0.05
Rod position	mm	:	-
Port closing mark	Cyl. No.	:	-
Cam sequence		:	1 - 3 - 4 - 2

Port closing mark	Cyl. No.	:	-
Port closing difference	°NW	:	0-90-180-270

Tolerance	+ - °C	:	0.50 (0.75)
-----------	--------	---	-------------

B1

ZEXEL - Test values
Injection pumps



Injection Quantity :

Adjusting Point	Rack Position (mm)	Pump Speed (r.p.m)	Injection Q'ty (cm ³ /1000 str.)	Difference (%)	Fixed	Remarks
	10.6	1000	55.1 ± 1.0	± 2.5	Rack	Basic
	approx. 9.5	325	10.0 ± 1.3	± 10.0	Rack	
A	R ₁ (10.6)	1000	55.1 ± 1.0	-	Lever	Basic Boost pressure kPa (mmHg) above 42.6 (above 320)
B	R ₁ +0.3	1750	71.0 ± 2.0	-	Lever	Boost pressure kPa (mmHg) above 42.6 (above 320)
C	R ₂ (R ₁ -0.4)	700	(39.9 ± 2.0)	-	Lever	
D	R ₂ +0.4	500	(35.7 ± 2.0)	-	Lever	
E	-	100	69.5 ± 2.5	-	Lever	Control rack limit

Timing Advance Specification : EP/SCDM
105676-0250

Pump Speed (r.p.m)							
Advance Angle (deg.)							

B2

ZEXEL - Test values
Injection pumps



B3

ZEXEL - Test values
Injection pumps



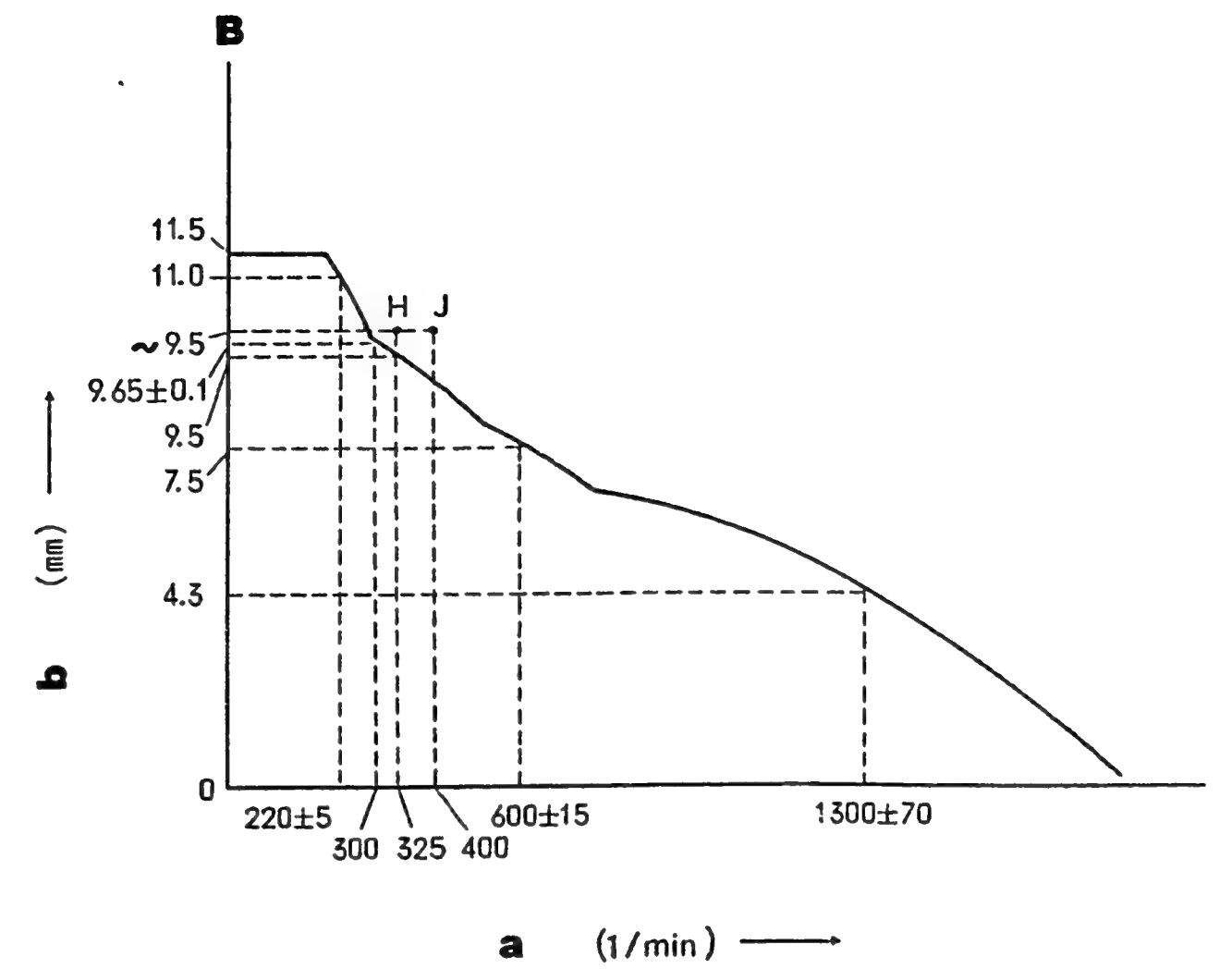
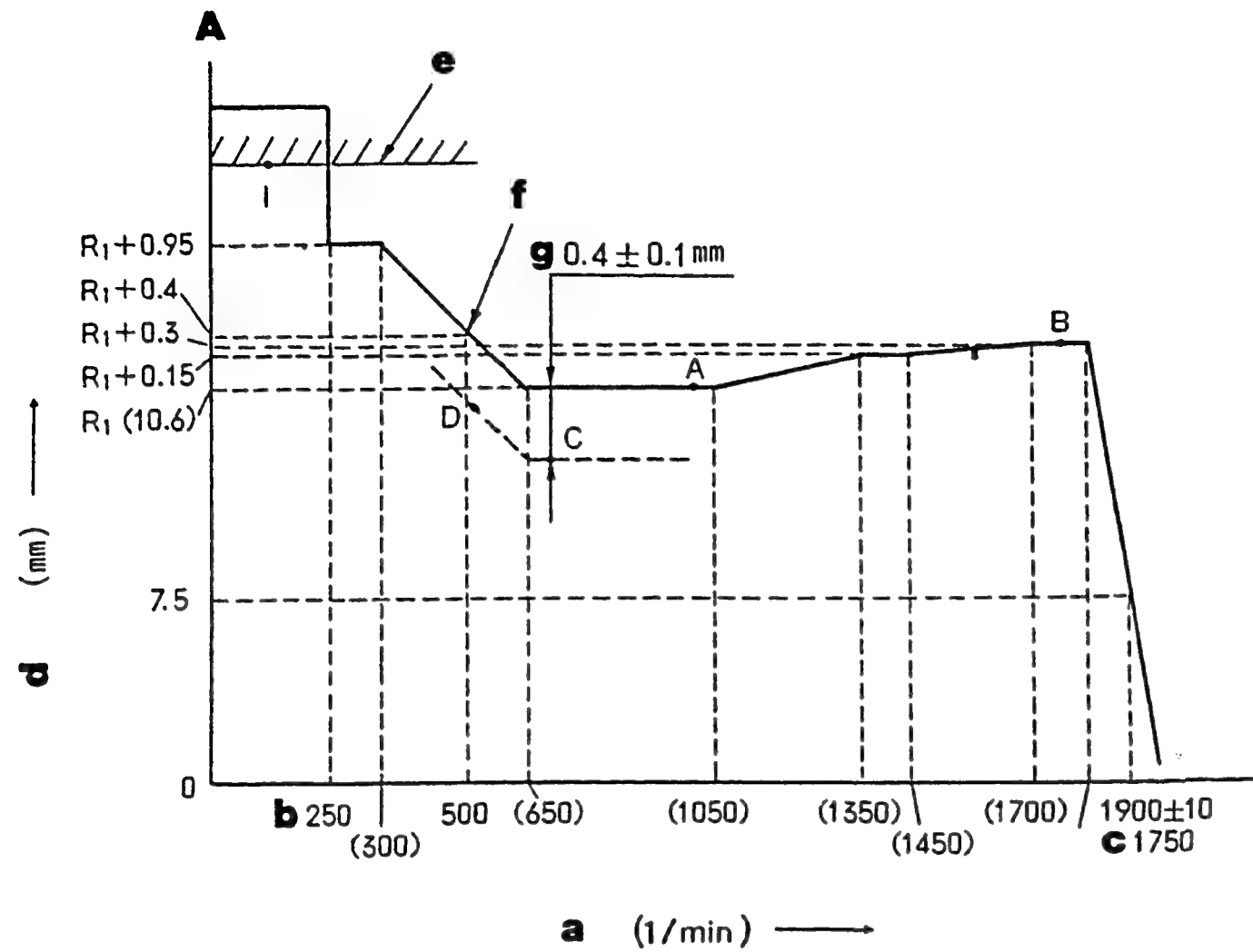

Figure 5

A = Full-Load Adjustment

- a = Pump speed
- b = Below
- c = Above
- d = Control rack position
- e = Control rack limit
- f = Torque cam adjustment
- g = Boost compensator stroke:

GOVERNOR ADJUSTMENT

B = Idle Adjustment

- a = Pump speed
- b = Control rack position

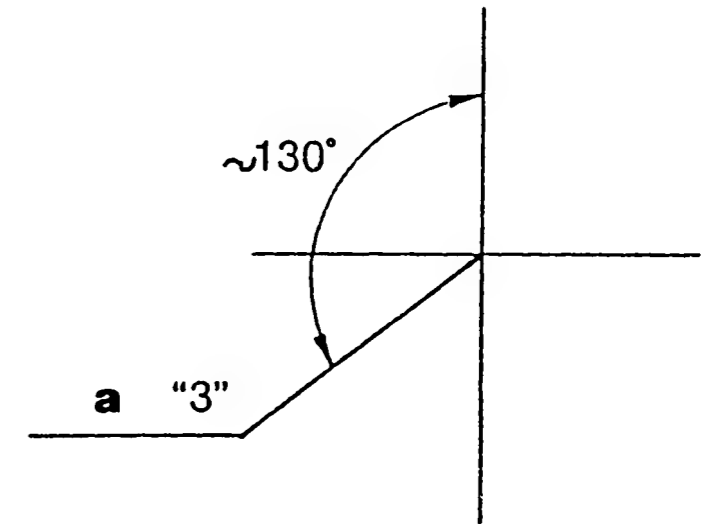
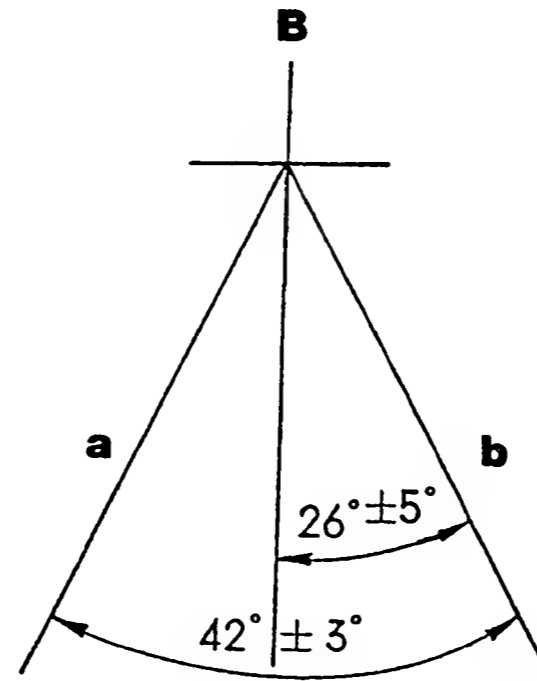
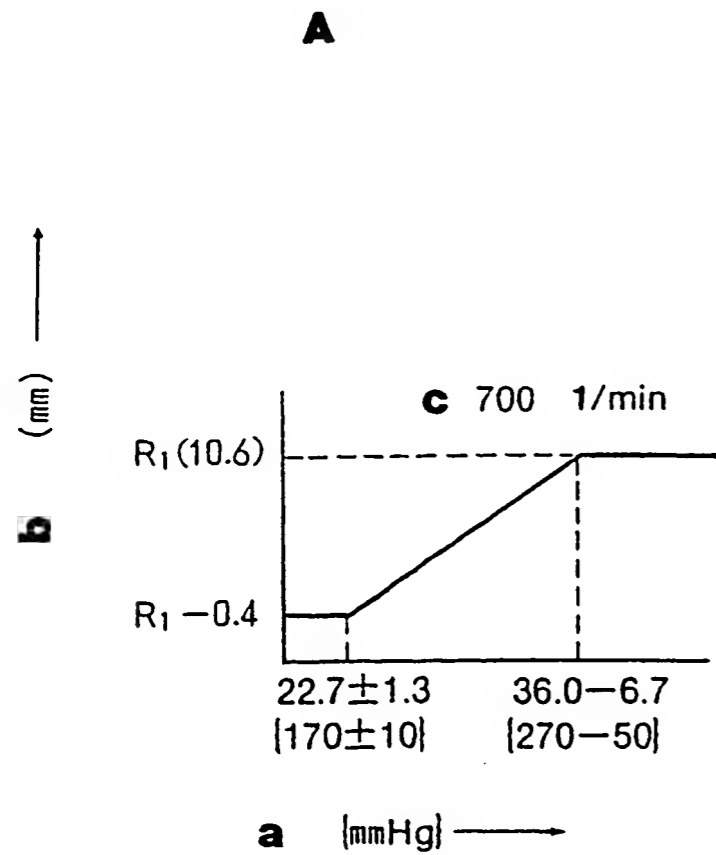

Figure 6

101401-1223 3/6

A = Boost Compensator Adjustment

a = Boost pressure
 b = Control rack position
 c = Perform at:

B = Speed Control Lever Angle

a = Full-speed
 b = Idling

■ **TIMING SETTING**

At No. 1 plunger's beginning of injection position B.T.D.C: 11°

a = Gear mark

B6

ZEXEL - Test values
 Injection pumps



B7

ZEXEL - Test values
 Injection pumps



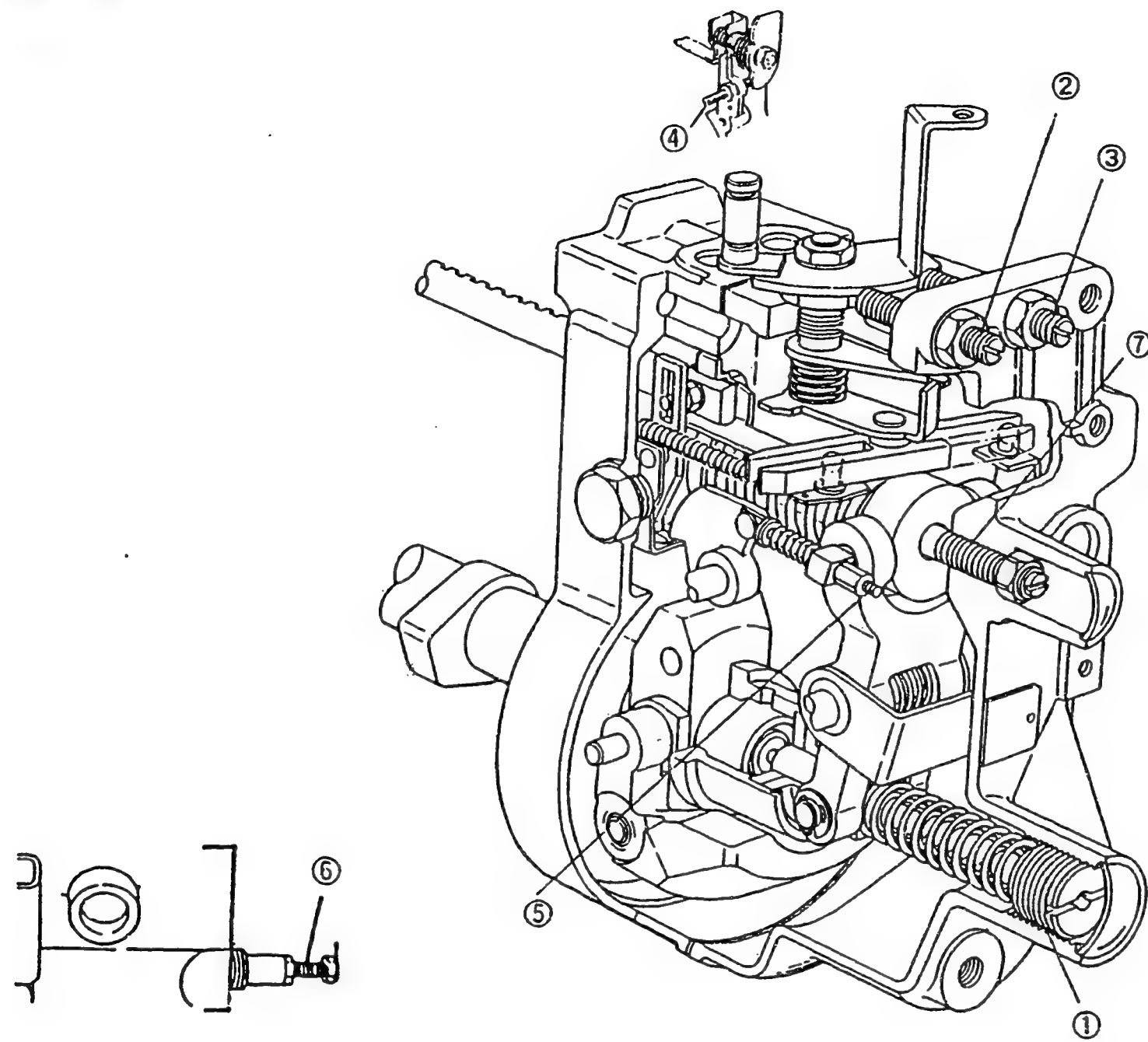

Figure 7

401-1223 4/6

- 1 = Spring capsule
- 2 = Screw
- 3 = Screw
- 4 = Screw

- 5 = Screw
- 6 = Screw
- 7 = Governor shaft

B8

ZEXEL - Test values
Injection pumps



B9

ZEXEL - Test values
Injection pumps



	Pump Speed (rpm)	Rack Position (mm)	Remarks
Idling Lever Position Temporary Setting	100	11.5	• Adjust using screw (2)
Idling Position Setting	220 ± 5 325	11.0 9.5	• Adjust using spring capsule (1) • Adjust using screw (2)
Governor Spring Contact Adjustment	600 ± 15 1300 ± 70	7.5 4.3	• Adjust the governor shaft position • Confirm
Setting the Idling Lever Position	325 -	approx. 9.5 -	• Adjust using screw (2) • Confirm the control lever angle (21° - 31°)

B10

ZEXEL - Test values

Injection pumps



B11

ZEXEL - Test values

Injection pumps



	Pump Speed (r.p.m)	Rack Position (mm)	Remarks
Full Speed Lever Position Temporary Setting	1750	R ₁ (10.6)	• Adjust using screw (3)
Full Load Position Adjustment	1000	R ₁ (10.6)	• Adjust using screw (4)
Torque Cam Position Adjustment	500 approx. 300 650 1050 1350 1450 1700	R ₁ + 0.4 R ₁ + 0.95 R ₁ (10.6) R ₁ (10.6) R ₁ + 0.15 R ₁ + 0.15 R ₁ + 0.3	• Adjust using screw (5) • Confirm • Confirm • Confirm • Confirm • Confirm • Confirm
Confirm injection quantity at point A			
Maximum Speed Control Adjustment	above 1750 1900 ± 10 -	R ₁ + 0.3 7.5 -	• Adjust using screw (3) • Confirm • After adjustment confirm that the control lever angle is 39° - 45°
Confirming Excess Fuel Limit for Engine Starting	400 0	approx. 9.5 11.5	• Set the control lever at point J • Confirm • Move the control lever to the "full-speed" position and then confirm the control rack position
Confirm the Black Smoke Limit	Fix the control lever at point H. Then operate the pump at 250 rpm. Confirm that the control rack does not move beyond R ₁ +0.95 mm. When the control lever is moved to the "full-speed" position again increase the pump speed and confirm that the control rack starts to move from a pump speed of 300 rpm.		
Rack Limiter Adjustment	Fix the control lever in the full speed position, and fix the control rack using the screw when the pump speed reaches 100 rpm and the fuel injection quantity obtained is 62 - 72 cm ³ /1000st.		
	Measure the depth of the control rack cap. Then adjust screw (6) so that it equals the depth of the rack cap and install the rack cap. Confirm injection quantities.		

B12 ZEXEL - Test values
Injection pumps



B13 ZEXEL - Test values
Injection pumps



	Boost pressure kPa (mmHg)	Rack position (mm)	Remarks
Boost Compensator Spring Adjustment	0	10.6 → 10.2	• Adjust using screw (8)
Setting the Boost Compensator Spring Force	22.7 ± 1.3 (170 ± 10)	R ₁ -0.4	• Adjust using screw (7)
	36.0 -6.7 (270 -50)	R ₁ (10.6)	• Confirm the boost compensator stroke is 0.4 ± 0.1 mm

■ BOOST COMPENSATOR ADJUSTMENT

Maintain the pump speed at 700 rpm and fix the control lever in the full load position.

In this condition, use calipers to measure the dimension „L” of the pushrod from the end face of the spacer.

(Inspection: 23.5 to 24.5 mm)

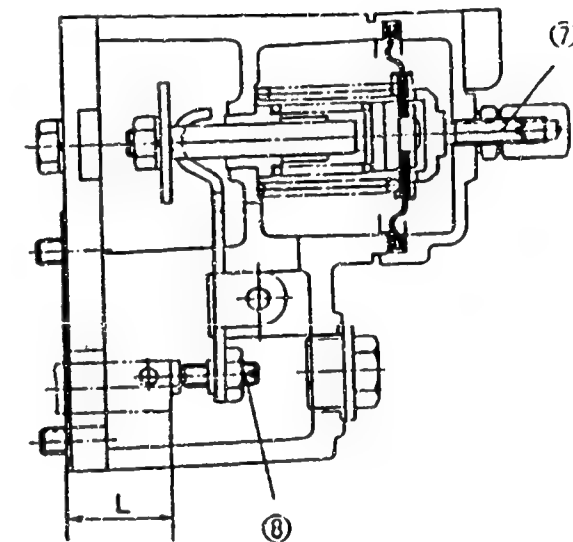

Figure 8

7 = Screw

8 = Screw

B14

ZEXEL - Test values

Injection pumps



B15

ZEXEL - Test values

Injection pumps



ZEXEL - TEST VALUES
Injection pumps

BOSCH No.	:	9 400 610 190	1/6
ZEXEL No.	:	101401-1342	
Date	:	31.10.1992	[1]
Company	:	MITSUBISHI	
Engine	:	4D31T / ME016751	

IP-Type number	:	101040-9550 / PES4A
Governor type number	:	105921-2851/EP/RLD-E

TEST PREREQUISITES

Test oil	:	ISO-4113
Test oil inlet temperature °C	:	40.00...45.00
Inlet pressure bar	:	1.6
Test nozzle holder combination	:	1 688 901 013
Opening pressure bar	:	175
Test pressure line	:	
Inner x Outer Dia - Length mm	:	2.00 x 6.00 x 600

PORT CLOSING

Prestroke	mm	:	3.6 ± 0.05
Rod position	mm	:	-
Port closing mark Cyl. No.	:	:	-
Cam sequence	:	:	1 - 3 - 4 - 2
Port closing mark Cyl. No.	:	:	-
Port closing difference °NW	:	:	0-90-180-270
Tolerance	+ - °C	:	0.50 (0.75)

C1

ZEXEL - Test values
Injection pumps



Injection Quantity :

Adjusting Point	Rack Position (mm)	Pump Speed (r.p.m)	Injection Q'ty (cm ³ /1000 str.)	Difference (%)	Fixed	Remarks
	12.1	1000	63.0 ± 1.6	± 2.5	Rack	Basic
H	approx. 9.5	325	10.2 ± 1.3	± 10.0	Rack	
A	R ₁ (12.1)	1000	63.0 ± 1.0	-	Lever	Basic Boost pressure kPa (mmHg) above 49.3 (above 370)
B	R ₁ +0.3	1750	(62.2 ± 2.0)	-	Lever	Boost pressure kPa (mmHg) above 49.3 (above 370)
C	R ₁ -0.7	700	(52.5 ± 2.0)	-	Lever	Boost pressure 0
D	-	500	(55.4 ± 2.0)	-	Lever	Boost pressure 0
I	-	100	(74.5 ± 2.5)	-	Lever	Control rack limit

Timing Advance Specification : EP/SCDM
105676-0250

Pump Speed (r.p.m)	1700						
Advance Angle (deg.)	Finish 3.5±0.5						

4

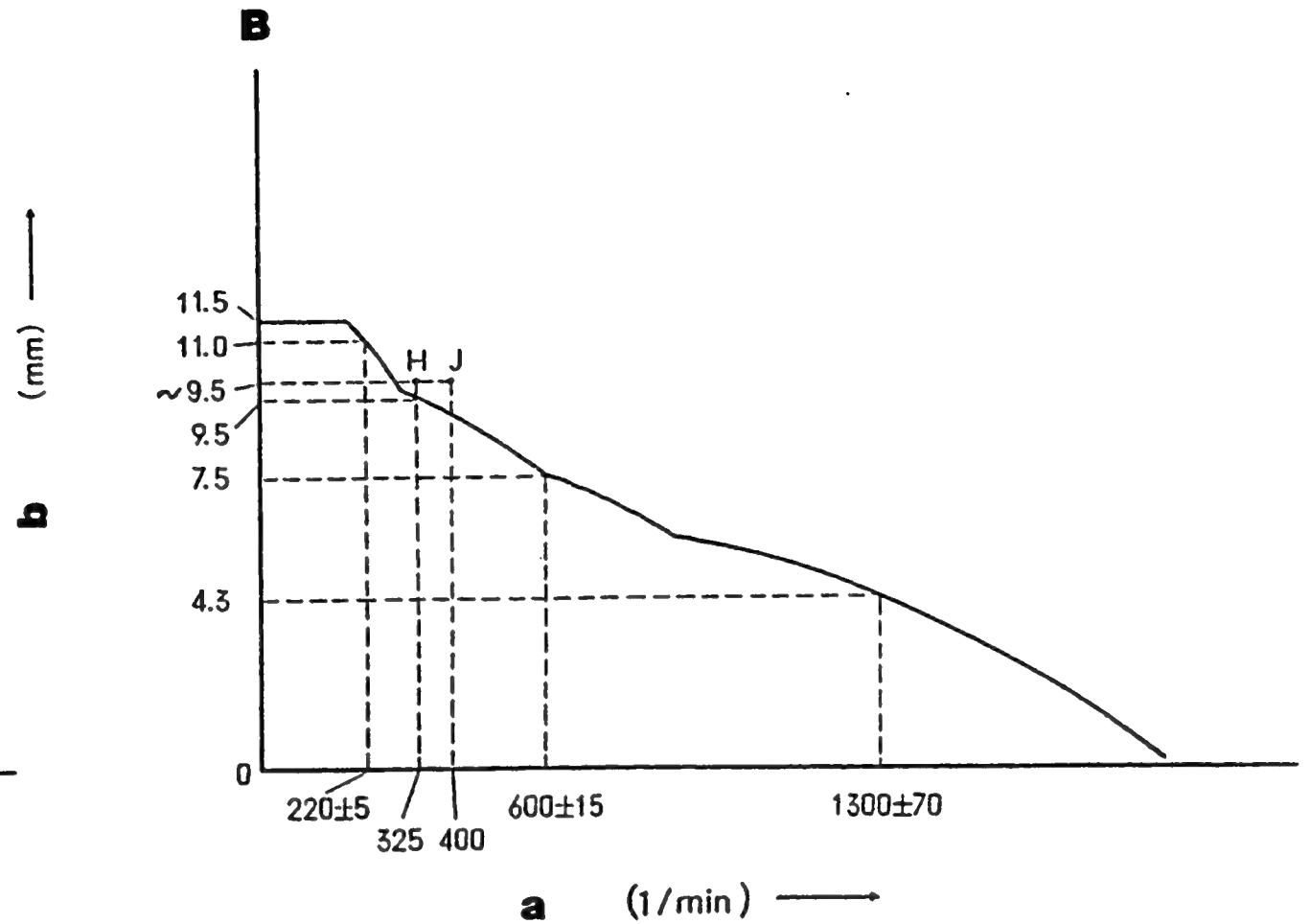
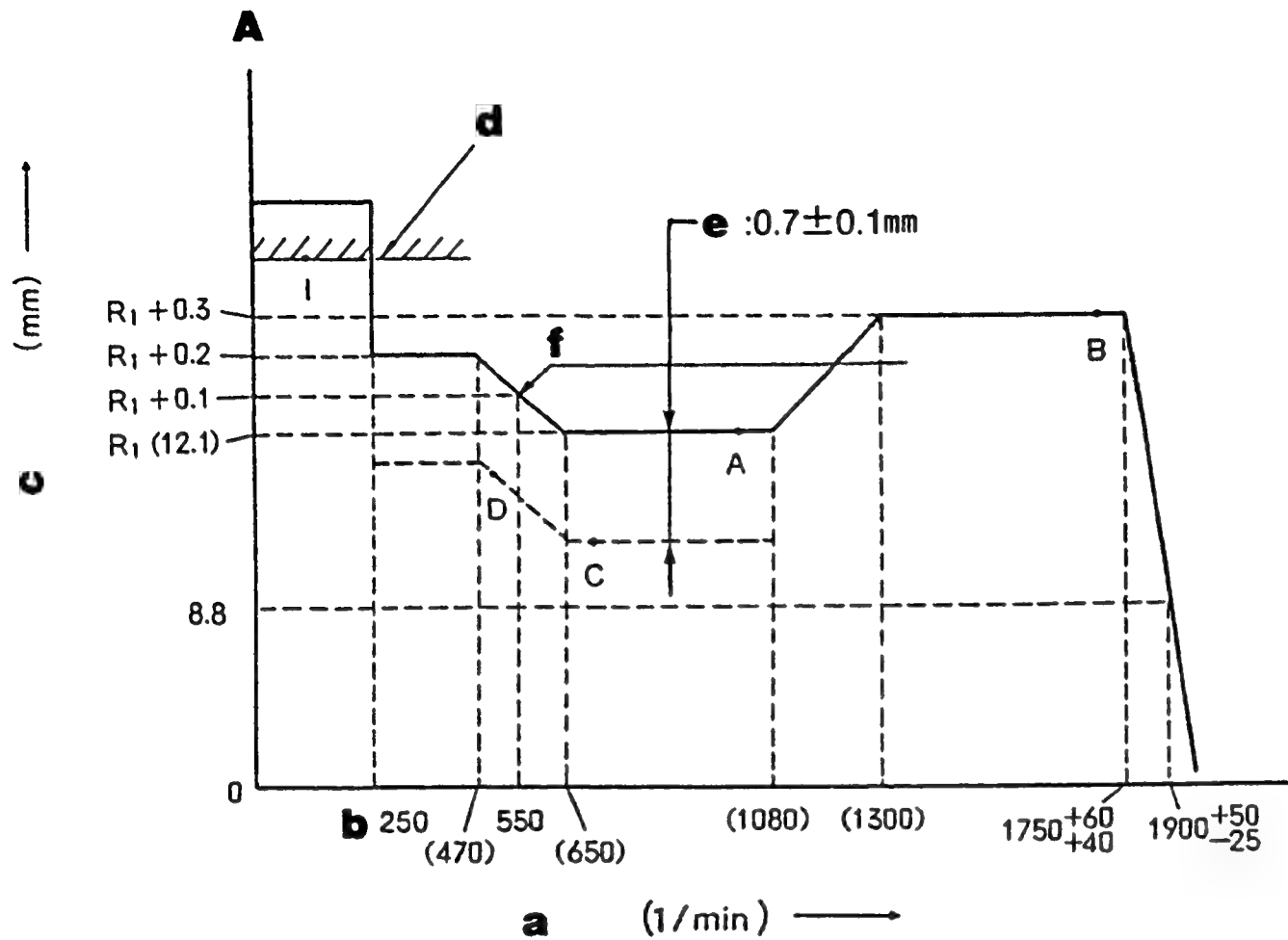

Figure 9

A = Full-Load Adjustment

- a = Pump speed
- b = Below
- c = Control rack position
- d = Control rack limit
- e = Boost compensator stroke:
- f = Torque cam adjustment

GOVERNOR ADJUSTMENT

101401-1342 2/6

B = Idle Adjustment

- a = Pump speed
- b = Control rack position

C4

ZEXEL - Test values
Injection pumps



C5

ZEXEL - Test values
Injection pumps



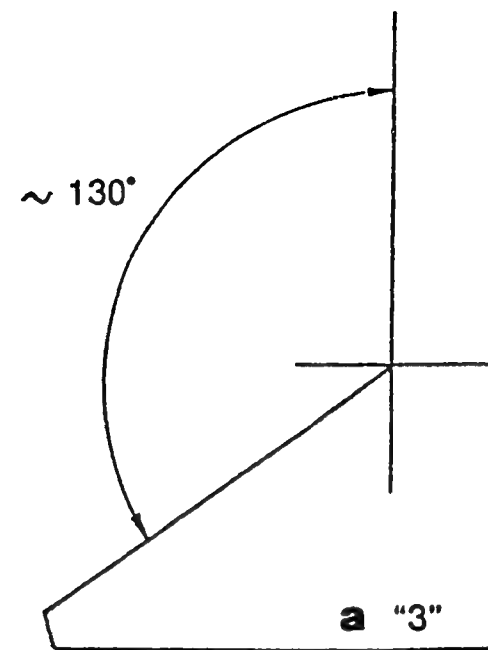
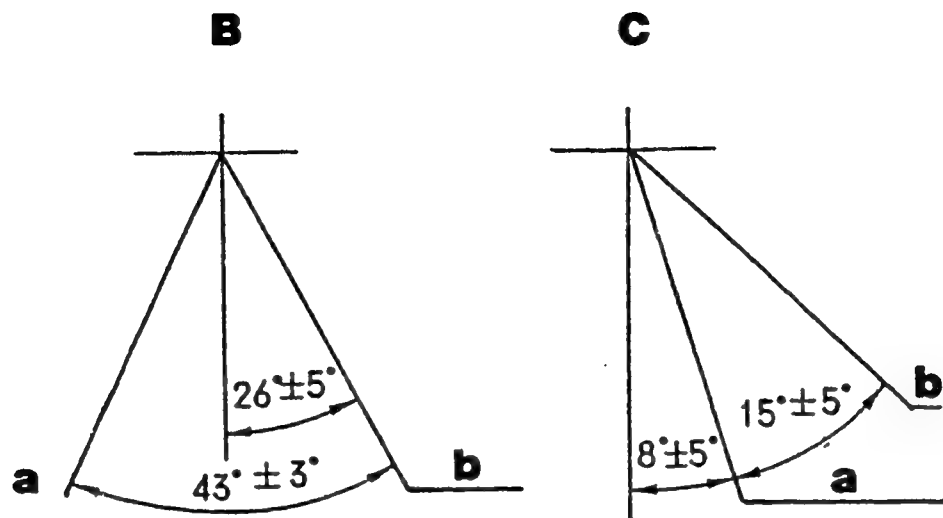
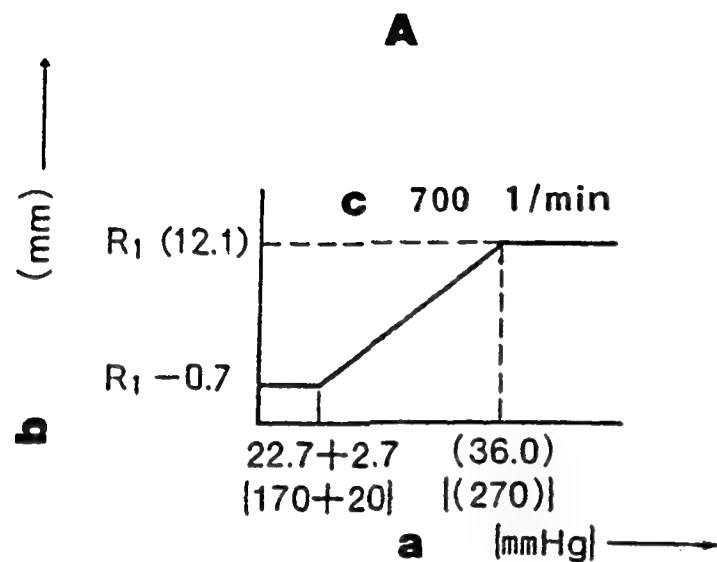

Figure 10

101401-1342 3/6

A = Boost Compensator Adjustment
a = Boost pressure
b = Control rack position
c = Perform at:

B = Speed Control Lever Angle
a = Full-speed
b = Idling

C = Stop Lever Angle
a = Stop
b = Normal

■ **TIMING SETTING**

At No. 1 plunger's beginning of injection position. B.T.D.C: 11°

a = Gear mark

C6

ZEXEL - Test values
 Injection pumps



C7

ZEXEL - Test values
 Injection pumps



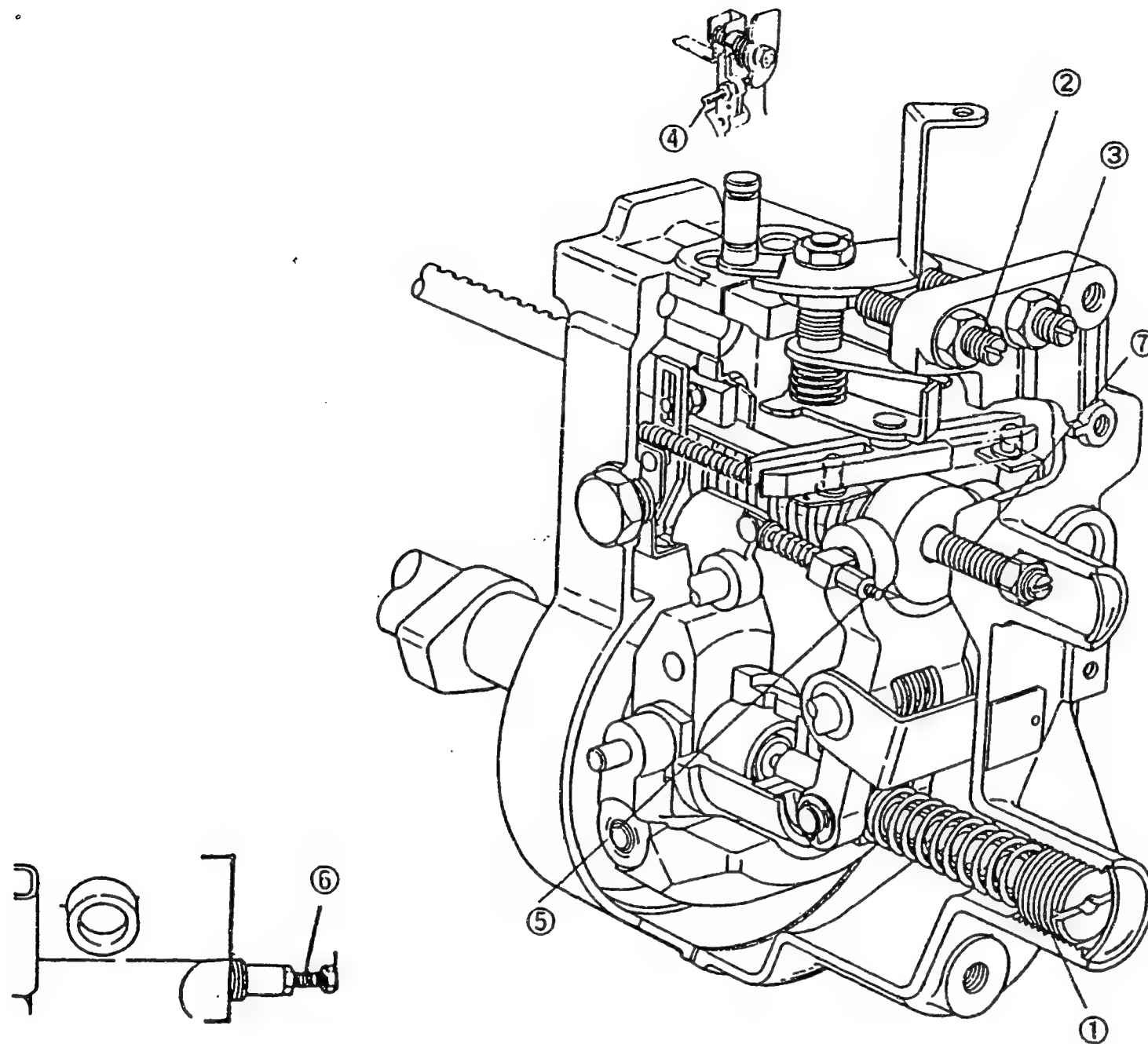

Figure 11

101401-1342 4/6

- 1 = Spring capsule
- 2 = Screw
- 3 = Screw
- 4 = Screw

- 5 = Screw
- 6 = Screw
- 7 = Governor shaft

C8

ZEXEL - Test values
Injection pumps



C9

ZEXEL - Test values
Injection pumps



	Pump Speed (rpm)	Rack Position (mm)	Remarks
Idling Lever Position Temporary Setting	100	11.5	• Adjust using screw (2)
Idling Position Setting	220 ± 5 325	11.0 9.5	• Adjust using spring capsule (1) • Adjust using screw (2)
Governor Spring Contact Adjustment	600 ± 15 1300 ± 70	7.5 4.3	• Adjust the governor shaft position • Confirm
Setting the Idling Lever Position	325	approx. 9.5	• Adjust using screw (2) • Confirm the control lever angle (21° - 31°)

C10	ZEXEL - Test values	
	Injection pumps	

C11	ZEXEL - Test values	
	Injection pumps	

	Pump Speed (r.p.m)	Rack Position (mm)	Remarks
Full Speed Lever Position Temporary Setting	1750	12.4	• Adjust using screw (3)
Full Load Position Adjustment	1000	R ₁ (12.1)	• Adjust using screw (4)
Torque Cam Position Adjustment	550 (470) (650) (1080) (1300)	R ₁ +0.1 R ₁ +0.2 R ₁ (12.1) R ₁ (12.1) R ₁ +0.3	• Adjust using screw (5) • Confirm • Confirm • Confirm • Confirm
Confirm injection quantity at point A			
Maximum Speed Control Adjustment	1750+60 +40 1900+50 -25	R ₁ +0.3 8.8	• Adjust using screw (3) • Confirm • After adjustment confirm that the control lever angle is 39° - 45°
Confirming Excess Fuel Limit for Engine Starting	400 0	approx. 9.5 11.5	• Set the control lever at point J • Confirm • Move the control lever to the "full-speed" position and then confirm the control rack position
Confirm the Black Smoke Limit	Fix the control lever at point H. Then operate the pump at 250 rpm. Confirm that the control rack does not move beyond R ₁ +0.95 mm. When the control lever is moved to the "full-speed" position again increase the pump speed and confirm that the control rack starts to move from a pump speed of 300 rpm.		
Rack Limiter Adjustment	Fix the control lever in the full speed position, and fix the control rack using the screw when the pump speed reaches 100 rpm and the fuel injection quantity obtained is 62 - 72 cm ³ /1000st.		
	Measure the depth of the control rack cap. Then adjust screw (6) so that it equals the depth of the rack cap and install the rack cap. Confirm injection quantities.		

C12

ZEXEL - Test values
Injection pumps



C13

ZEXEL - Test values
Injection pumps



	Boost pressure kPa (mmHg)	Rack position (mm)	Remarks
Boost Compensator Spring Adjustment	0	12.1 → 11.4	• Adjust using screw (7)
Setting the Boost Compensator Spring Force	22.7+2.7 (170+20)	R (12.1)	• Adjust using screw (8)
	approx. 36.0 (270)	R (12.1)	• Confirm the boost compensator stroke is 0.7 ± 0.1 mm

■ BOOST COMPENSATOR ADJUSTMENT

Maintain the pump speed at 700 rpm and fix the control lever in the full load position.

In this condition, use calipers to measure the dimension „L” of the pushrod from the end face of the spacer.

(Inspection: 23.5 to 24.5 mm)

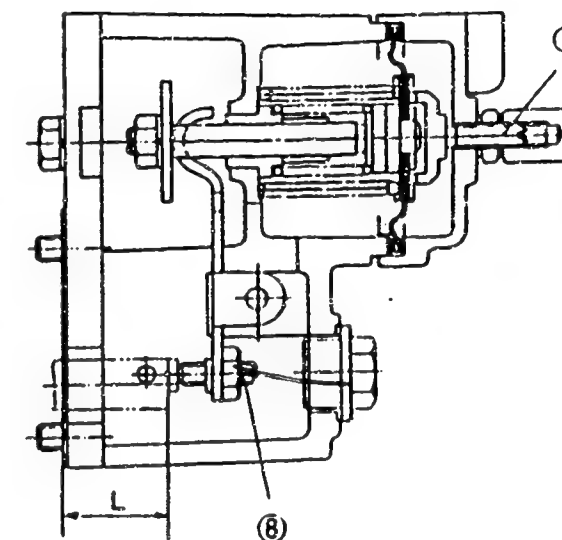

Figure 12

7 = Screw

8 = Screw

C14

ZEXEL - Test values
Injection pumps



C15

ZEXEL - Test values
Injection pumps



ZEXEL - TEST VALUES
Injection pumps

BOSCH No.	:	9 400 610 192	1/4
ZEXEL No.	:	101402-3300	
Date	:	31.10.1992	[2]
Company	:	KOMATSU	
Engine	:	S4D105 / 6131-71-1601	

IP-Type number : 101040-9000 / PES4AD
Governor type number : 105402-1790 / EP/RSV

TEST PREREQUISITES

Test oil : ISO-4113
Test oil inlet temperature °C : 40.00...45.00
Inlet pressure bar : 1.6
Test nozzle holder combination : 1 688 901 013
Opening pressure bar : 175
Test pressure line
Inner x Outer Dia - Length mm : 2.00 x 6.00 x 600

PORT CLOSING

Prestroke mm : 2.1 ± 0.05
Rod position mm : -
Port closing mark Cyl. No. : -
Cam sequence : 1 - 2 - 4 - 3

Port closing mark Cyl. No. : -
Port closing difference °NW : 0-90-180-270

Tolerance +- °C: 0.50 (0.75)



Injection Quantity :

Adjusting Point	Rack Pos. (mm)	P. Speed (rpm)	Injection Q'ty (cm ³ /1000 str.)	Difference (%)	Fixed	Remarks
A	8.4	1200	86.0 ± 1.0	± 2	Rack	Basic
H	6.4	375	14.0 ± 1.4	± 10	Rack	
A	8.4	1200	86.0 ± 1.0	-	Lever	Basic
C	11.9	100	118.0 ± 10.0	-	Lever	

Timing Advance Specification :

Speed (rpm)						
Advance Angle (deg)						

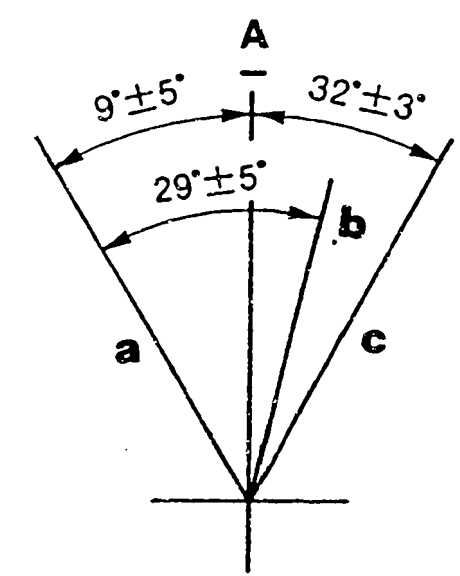
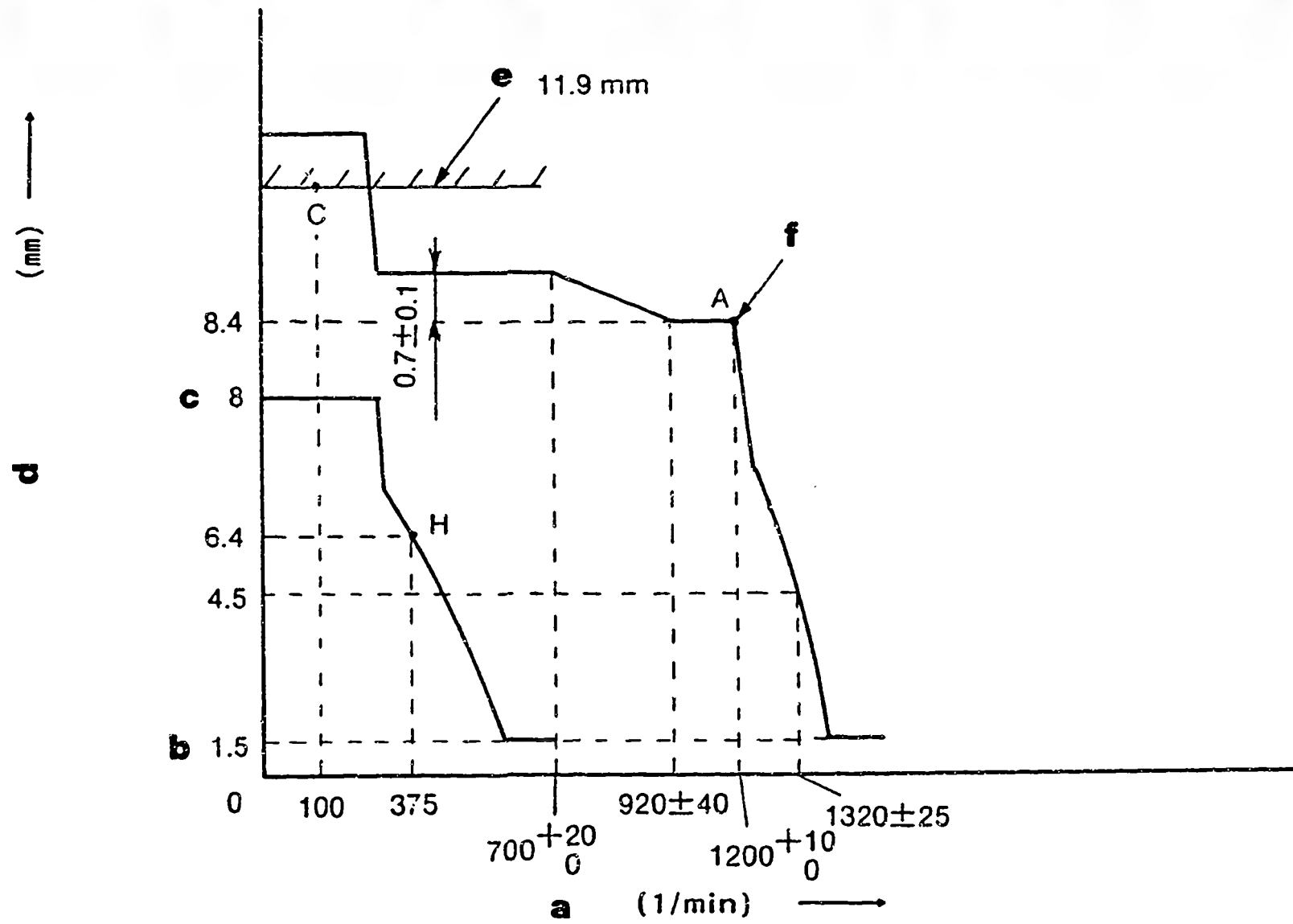

Figure 13

GOVERNOR ADJUSTMENT

101402-3300 2/4

Recommended speed droop adjustment screw position: 12

- a = Pump speed
- b = Below
- c = Above
- d = Control rack position
- e = Control rack limit:
- f = Torque spring adjustment is only performed when necessary

- A = Speed Control Lever Angle
- a = Full-speed
- b = Idling
- c = Stop

■ Note

- Before adjustment, remove the idling sub spring.
- Move the control lever fully in the stop direction, and set the minimum-speed stopper bolt so that the control rack position is 0.5 - 1.0 mm.

■ . ADJUSTMENT

	Pump speed (rpm)	Rack position (mm)	Remarks
Full-load Adjustment (Temporary)	1400	8.4	<ul style="list-style-type: none"> • Adjust using screw (2) • Adjust using screw (1)
	600	8.4	
Torque Control spring Adjustment	600	9.1	<ul style="list-style-type: none"> • Adjust using spring capsule (4) • Confirm • Confirm the torque control stroke is 0.7 ± 0.1 mm
	700+20	9.1	
	0 920±40	8.4	
Idling Adjustment	0	above 8	<ul style="list-style-type: none"> • Fix the control lever • Adjust using spring capsule (5) • Confirm
	375	6.4	
Maximum-speed Adjustment	1200+10	8.4	<ul style="list-style-type: none"> • Fix the control lever • Confirm speed droop - adjust using screw (3) • Confirm
	0 1320±25	4.5	
Full-load Adjustment	1200	8.4	<ul style="list-style-type: none"> • Confirm
Control Lever Angle Measurement	<ul style="list-style-type: none"> • Measure the control lever angle at the "idling" and "full" positions. • When the control lever is depressed toward the "full" position, replace the shifter's shim with a thicker one. • When the control lever is depressed toward the "idling" position, replace the shifter's shim with a thinner one. 		
Rack Limiter Adjustment	100	11.9	<ul style="list-style-type: none"> • Adjust using screw

C21

ZEXEL - Test values
Injection pumps



C22

ZEXEL - Test values
Injection pumps



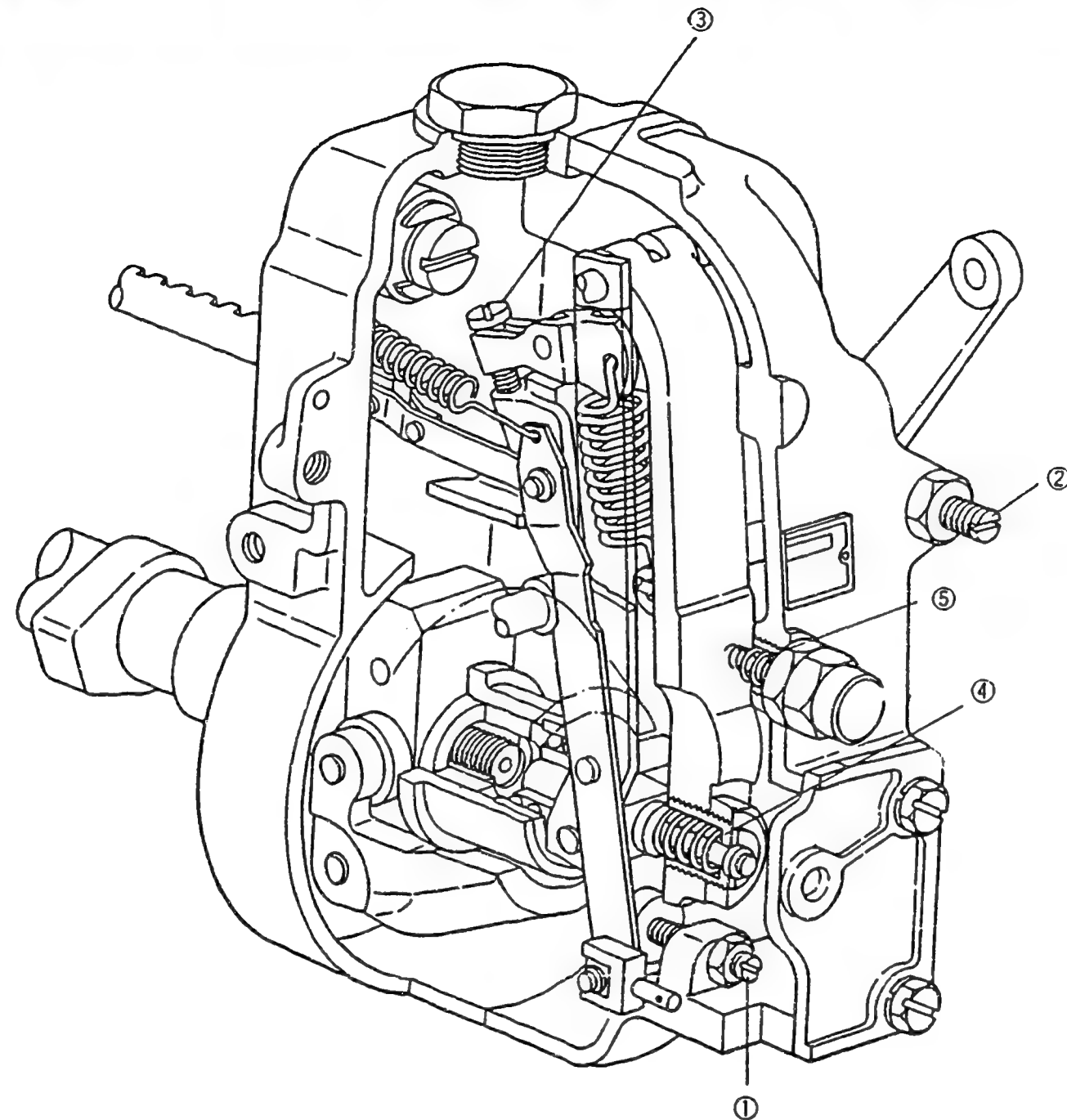

Figure 14

- 1 = Screw
- 2 = Screw
- 3 = Screw
- 4 = Spring capsule
- 5 = Spring capsule

101402-3300 4/4

C 23

ZEXEL - Test values
Injection pumps



C 24

ZEXEL - Test values
Injection pumps



ZEXEL - TEST VALUES
Injection pumps

BOSCH No.	:	9 400 610 193	1/4
ZEXEL No.	:	101452-3041	
Date	:	31.10.1992	[1]
Company	:	KOMATSU	
Engine	:	4D95L / 6204-72-1420	

IP-Type number	:	101045-8050 / PES4A
Governor type number	:	105400-7880 / EP/RSV

TEST PREREQUISITES

Test oil	:	ISO-4113
Test oil inlet temperature °C	:	40.00...45.00
Inlet pressure bar	:	1.6
Test nozzle holder combination	:	1 688 901 013
Opening pressure bar	:	175
Test pressure line	:	
Inner x Outer Dia - Length mm	:	2.00 x 6.00 x 600

PORT CLOSING

Prestroke	mm	:	1.5 ± 0.05
Rod position	mm	:	-
Port closing mark Cyl. No.	:	:	-
Cam sequence	:	:	1 - 2 - 4 - 3

Port closing mark Cyl. No.	:	:	-
Port closing difference °NW	:	:	0-90-180-270

Tolerance	+- °C	:	0.50 (0.75)
-----------	-------	---	-------------

D1

ZEXEL - Test values

Injection pumps



Injection Quantity :

Adjusting Point	Rack Pos. (mm)	P. Speed (rpm)	Injection Q'ty (cm ³ /1000 str.)	Difference (%)	Fixed	Remarks
A	12.0	900	45.8 ± 1.0	± 2.5	Rack	Basic
	approx. 8.3	400	11.0 ± 1.0	± 15.0	Rack	
A	12.0	900	45.8 ± 1.0	-	Lever	Basic

Timing Advance Specification :

Pump Speed (rpm)						
Advance Angle (deg)						

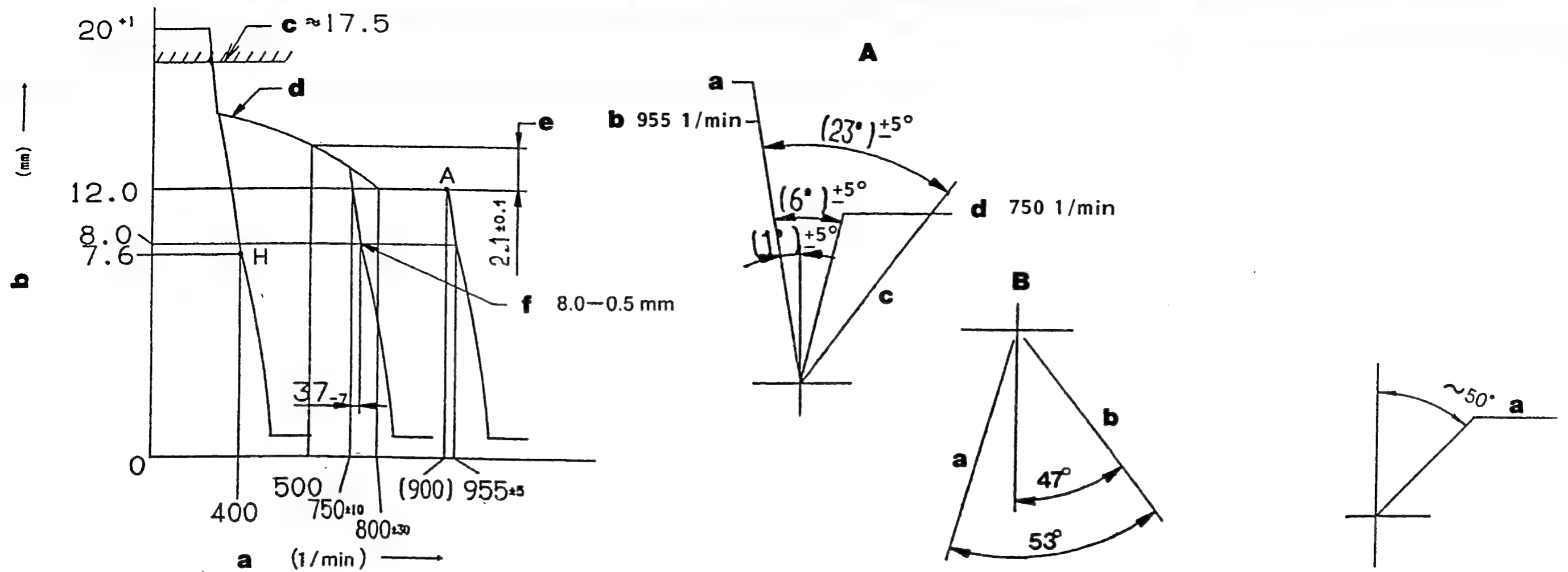

Figure 15

GOVERNOR ADJUSTMENT

101452-3041 2/4

Recommended speed droop adjustment screw position: 10

- a = Pump speed
- b = Control rack position
- c = Control rack limit:
- d = Perform torque control spring adjustment when necessary
- e = Difference in control rack position between 900 rpm and 500 rpm
- f = Idle-sub spring setting:

A = Speed Control Lever Angle

B = Stop Lever Angle

- a = Full-speed
- b = Setting:
(On our shipment)
- c = Idling
- d = Setting:

- a = Stop
- b = Normal

■ TIMING SETTING

At No. 1 plunger's beginning of injection position.

a = Key position

■ Note

- Before adjustment, remove the idling sub spring.
- Move the control lever fully in the stop direction, and set the minimum-speed stopper bolt so that the control rack position is 0.5 - 1.0 mm.

■ ADJUSTMENT

	Pump speed (rpm)	Rack position (mm)	Remarks
Full-load Adjustment (Temporary)	1100 600	12.0 12.0	<ul style="list-style-type: none"> • Adjust using screw (2) • Adjust using screw (1)
Torque Control spring Adjustment	500 800±30	14.1±0.1 12.0	<ul style="list-style-type: none"> • Adjust using spring capsule (4) • Confirm • Confirm the torque control stroke is 2.1 ± 0.1 mm
Idling Adjustment	750+37 +30 400	8.0+1 7.6	<ul style="list-style-type: none"> • Fix the control lever • Adjust using spring capsule (5) • Confirm
Maximum-speed Adjustment	900 955±5	12.0 8.0	<ul style="list-style-type: none"> • Fix the control lever • Confirm speed droop - adjust using screw (3) • Confirm
Full-load Adjustment	850	12.0	<ul style="list-style-type: none"> • Confirm
Control Lever Angle Measurement	<ul style="list-style-type: none"> • Measure the control lever angle at the "idling" and "full" positions. • When the control lever is depressed toward the "full" position, replace the shifter's shim with a thicker one. • When the control lever is depressed toward the "idling" position, replace the shifter's shim with a thinner one. 		
Rack Limiter Adjustment	0	17.5	<ul style="list-style-type: none"> • Adjust using screw

D6

ZEXEL - Test values
Injection pumps



D7

ZEXEL - Test values
Injection pumps



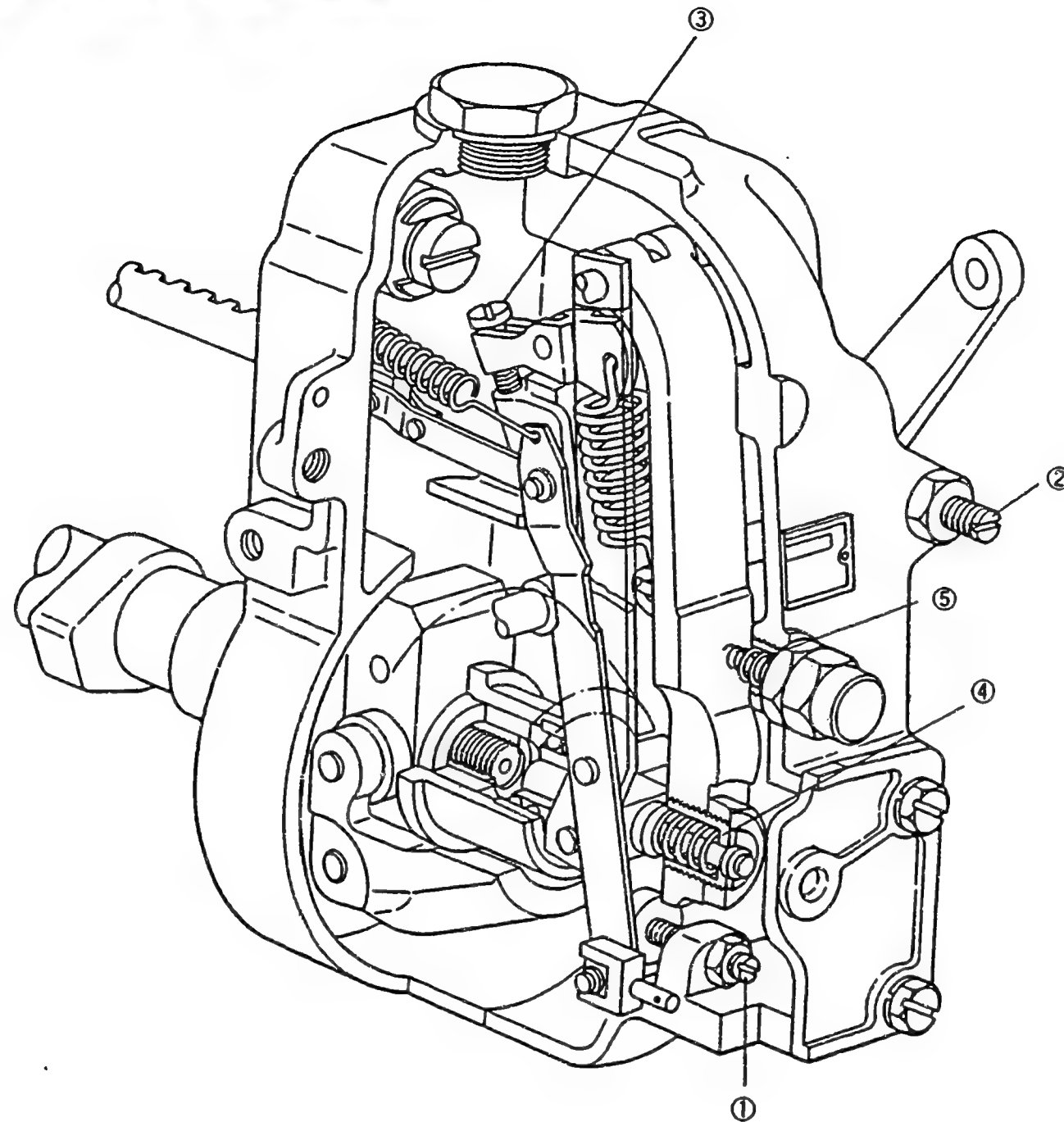

Figure 16

- 1 = Screw
- 2 = Screw
- 3 = Screw
- 4 = Spring capsule
- 5 = Spring capsule

D8	ZEXEL - Test values	
	Injection pumps	

D9	ZEXEL - Test values	
	Injection pumps	

ZEXEL - TEST VALUES
Injection pumps

BOSCH No.	:	9 400 610 194	1/4
ZEXEL No.	:	101452-3093	
Date	:	31.10.1992	[2]
Company	:	KOMATSU	
Engine	:	4D95L / 6204-72-1431	

IP-Type number	:	101045-8090 / PES4A
Governor type number	:	105400-7690 / EP/RSV

TEST PREREQUISITES

Test oil	:	ISO-4113
Test oil inlet temperature °C	:	40.00...45.00
Inlet pressure bar	:	1.6
Test nozzle holder combination	:	1 688 901 013
Opening pressure bar	:	175
Test pressure line	:	
Inner x Outer Dia - Length mm	:	2.00 x 6.00 x 600

PORT CLOSING

Prestroke mm	:	1.5 ± 0.05
Rod position mm	:	-
Port closing mark Cyl. No.	:	-
Cam sequence	:	1 - 2 - 4 - 3

Port closing mark Cyl. No.	:	-
Port closing difference °NW	:	0-90-180-270

Tolerance +- °C	:	0.50 (0.75)
-----------------	---	-------------

D10

ZEXEL - Test values
Injection pumps



Continued (Test values)

Injection Quantity :

Adjusting Point	Rack Pos. (mm)	P. Speed (rpm)	Injection Q'ty (cm ³ /1000 str.)	Difference (%)	Fixed	Remarks
A	12.0	900	45.8 ± 1.0	± 2.5	Rack	Basic
	approx. 8.3	400	11.0 ± 1.0	± 15.0	Rack	
A	12.0	900	45.8 ± 1.0	-	Lever	Basic

Timing Advance Specification :

Pump Speed (rpm)						
Advance Angle (deg)						

D11

ZEXEL - Test values
Injection pumps



D12

ZEXEL - Test values
Injection pumps



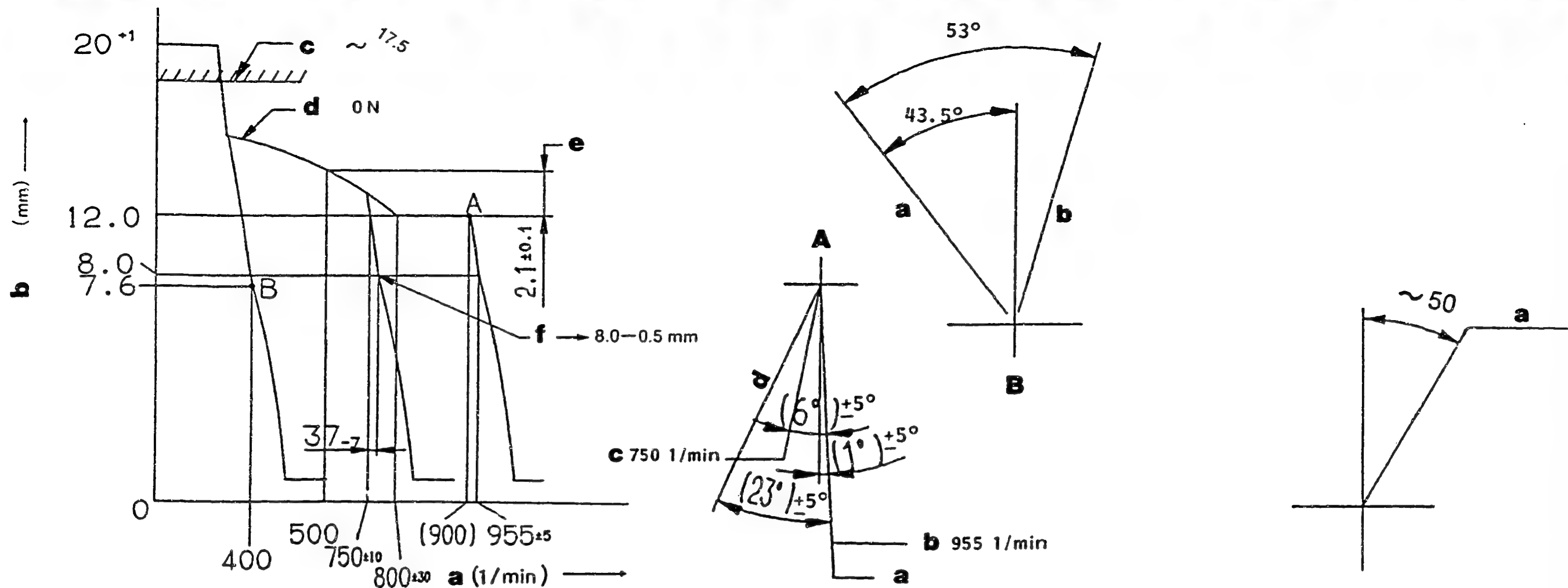

Figure 17

GOVERNOR ADJUSTMENT

Recommended speed droop adjustment screw position: 10

101452-3093 2/4

- a = Pump speed
- b = Control rack position
- c = Control rack limit:
- d = Perform torque control spring:
- e = Difference in control rack position between 900 rpm and 500 rpm
- f = Idle-sub spring setting:

A = Speed Control Lever Angle

- a = Full-speed
- b = Setting: (on our shipment)
- c = Setting:
- d = Idling

B = Stop Lever Angle

- a = Normal
- b = Stop

■ TIMING SETTING

At No. 1 plunger's beginning of injection position.

a = Key position

D13

ZEXEL - Test values
Injection pumps



D14

ZEXEL - Test values
Injection pumps



■ Note

- Before adjustment, remove the idling sub spring.
- Move the control lever fully in the stop direction, and set the minimum-speed stopper bolt so that the control rack position is 0.5 - 1.0 mm.

■ ADJUSTMENT

	Pump speed (rpm)	Rack position (mm)	Remarks
Full-load Adjustment (Temporary)	1100 600	12.0 12.0	<ul style="list-style-type: none"> • Adjust using screw (2) • Adjust using screw (1)
Torque Control spring Adjustment	500 800±30	14.1±0.1 12.0	<ul style="list-style-type: none"> • Adjust using spring capsule (4) • Confirm • Confirm the torque control stroke is 2.1 ± 0.1 mm
Idling Adjustment	750 ⁺³⁷ +27 400	8.0 7.6	<ul style="list-style-type: none"> • Fix the control lever • Adjust using spring capsule (5) • Adjust using control lever
Maximum-speed Adjustment	approx. 900 955±5	12.0 8.0	<ul style="list-style-type: none"> • Fix the control lever • Confirm speed droop - adjust using screw (3) • Confirm
Full-load Adjustment	850	12.0	<ul style="list-style-type: none"> • Confirm
Control Lever Angle Measurement	<ul style="list-style-type: none"> • Measure the control lever angle at the "idling" and "full" positions. • When the control lever is depressed toward the "full" position, replace the shifter's shim with a thicker one. • When the control lever is depressed toward the "idling" position, replace the shifter's shim with a thinner one. 		
Rack Limiter Adjustment	0	approx. 17.5	<ul style="list-style-type: none"> • Adjust using screw

D15

ZEXEL - Test values

Injection pumps



D16

ZEXEL - Test values

Injection pumps



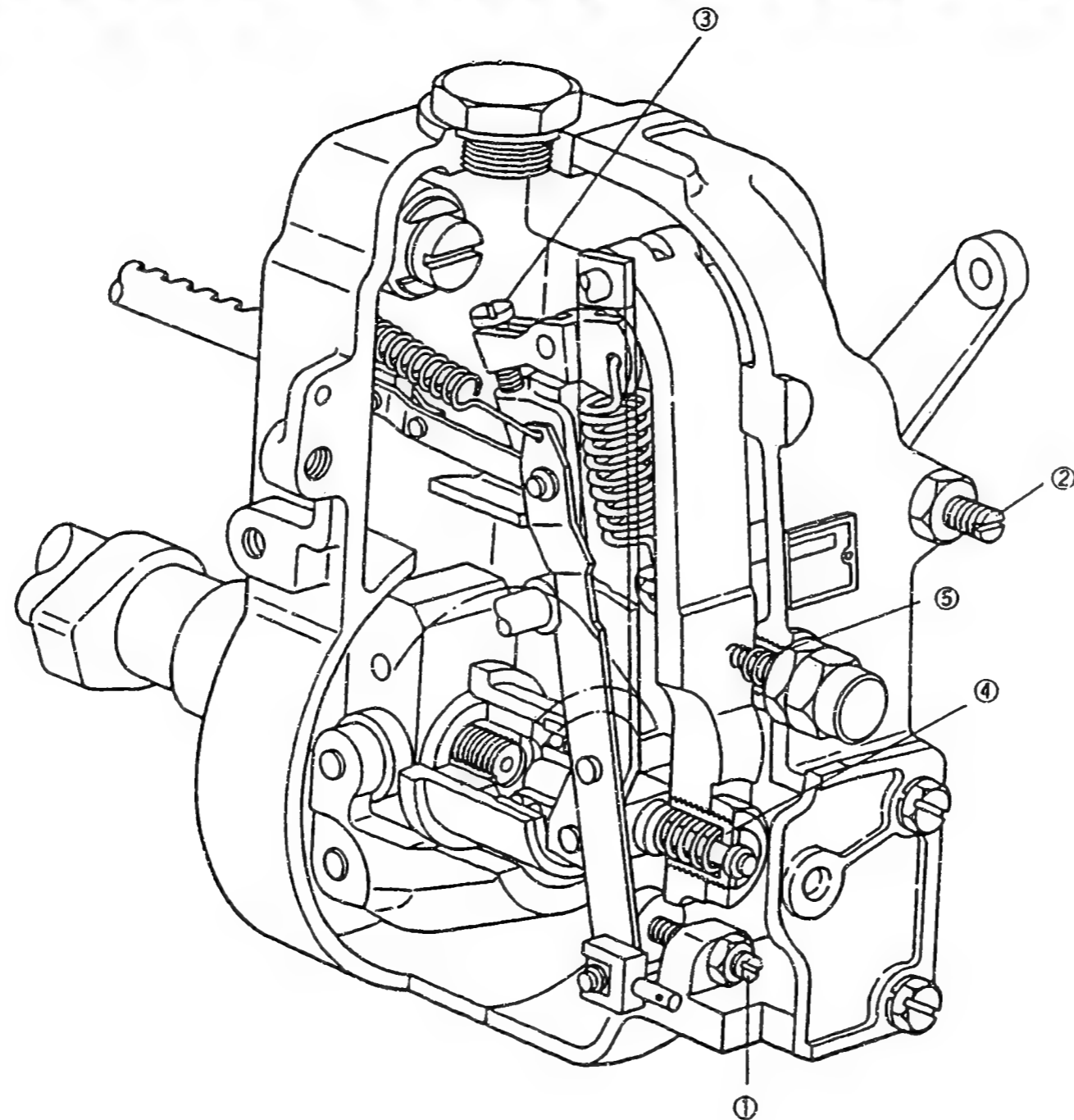

Figure 18

- 1 = Screw
- 2 = Screw
- 3 = Screw
- 4 = Spring capsule
- 5 = Spring capsule

101452-3093 4/4

D17

ZEXEL - Test values
Injection pumps



D18

ZEXEL - Test values
Injection pumps



ZEXEL - TEST VALUES
Injection pumps

BOSCH No.	:	9 400 610 191	1/4
ZEXEL No.	:	101492-3540	
Date	:	31.10.1992	[1]
Company	:	KOMATSU	
Engine	:	4D95L / 6204-71-1440	

IP-Type number	:	101049-8320 / PES4A
Governor type number	:	105400-4261 / EP/RSV

TEST PREREQUISITES

Test oil	:	ISO-4113
Test oil inlet temperature °C	:	40.00...45.00
Inlet pressure bar	:	1.6
Test nozzle holder combination	:	1 688 901 013
Opening pressure bar	:	175
Test pressure line	:	
Inner x Outer Dia - Length mm	:	2.00 x 6.00 x 600

PORT CLOSING

Prestroke mm	:	3.6 ± 0.05
Rod position mm	:	-
Port closing mark Cyl. No.	:	-
Cam sequence	:	1 - 2 - 4 - 3

Port closing mark Cyl. No.	:	-
Port closing difference °NW	:	0-90-180-270

Tolerance +- °C	:	0.50 (0.75)
-----------------	---	-------------



Injection Quantity :

Adjusting Point	Rack Pos. (mm)	P. Speed (rpm)	Injection Q'ty (cm ³ /1000 str.)	Difference (%)	Fixed	Remarks
A	9.6	850	36.5 ± 1.0	± 2.5	Rack	Basic
	approx. 8.2	375	6.2 ± 1.0	± 15.0	Rack	
A	9.6	850	36.5 ± 1.0	-	Lever	Basic

Timing Advance Specification :

Pump Speed (rpm)						
Advance Angle (deg)						

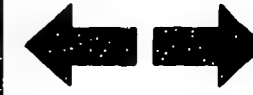

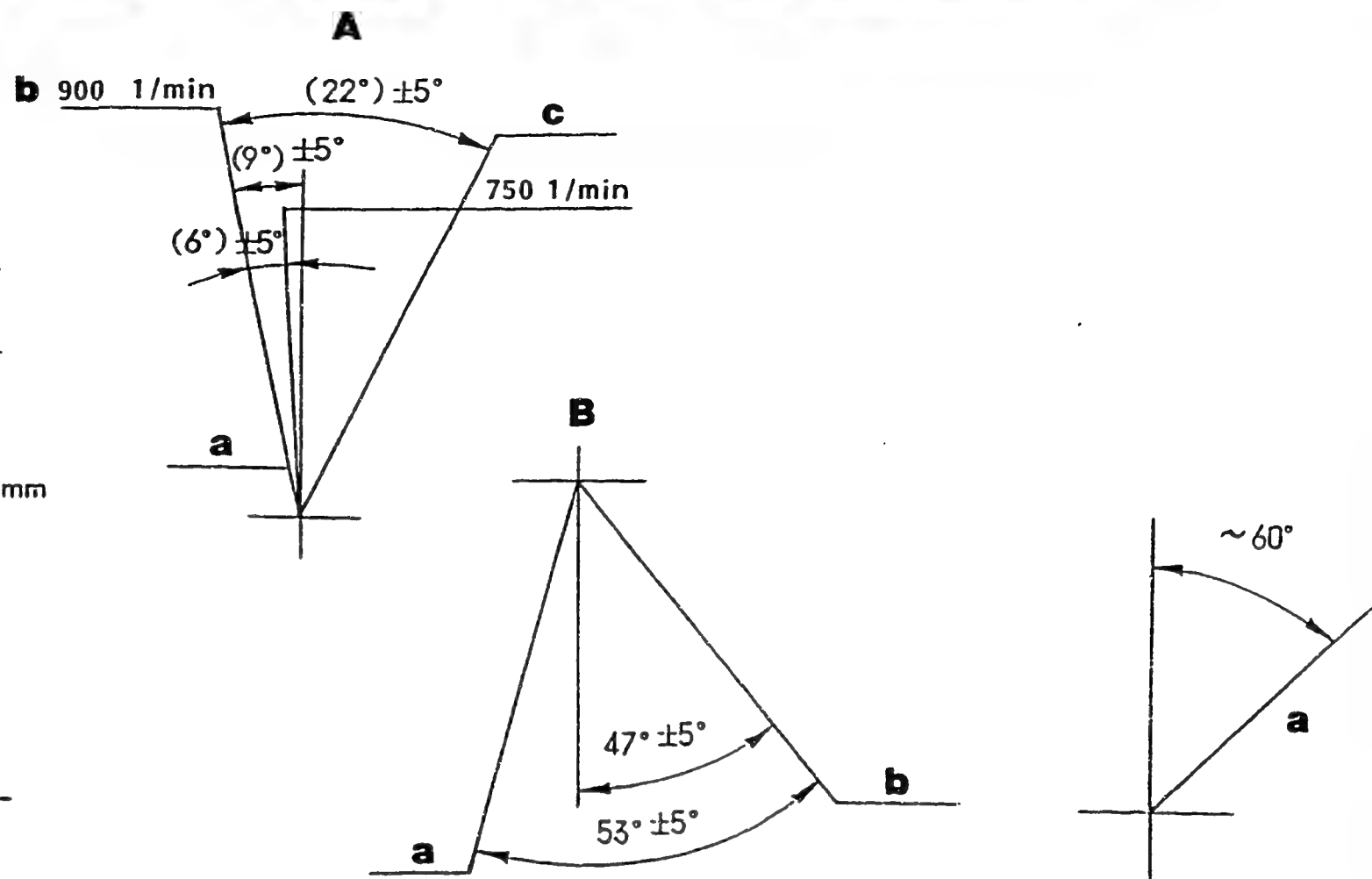
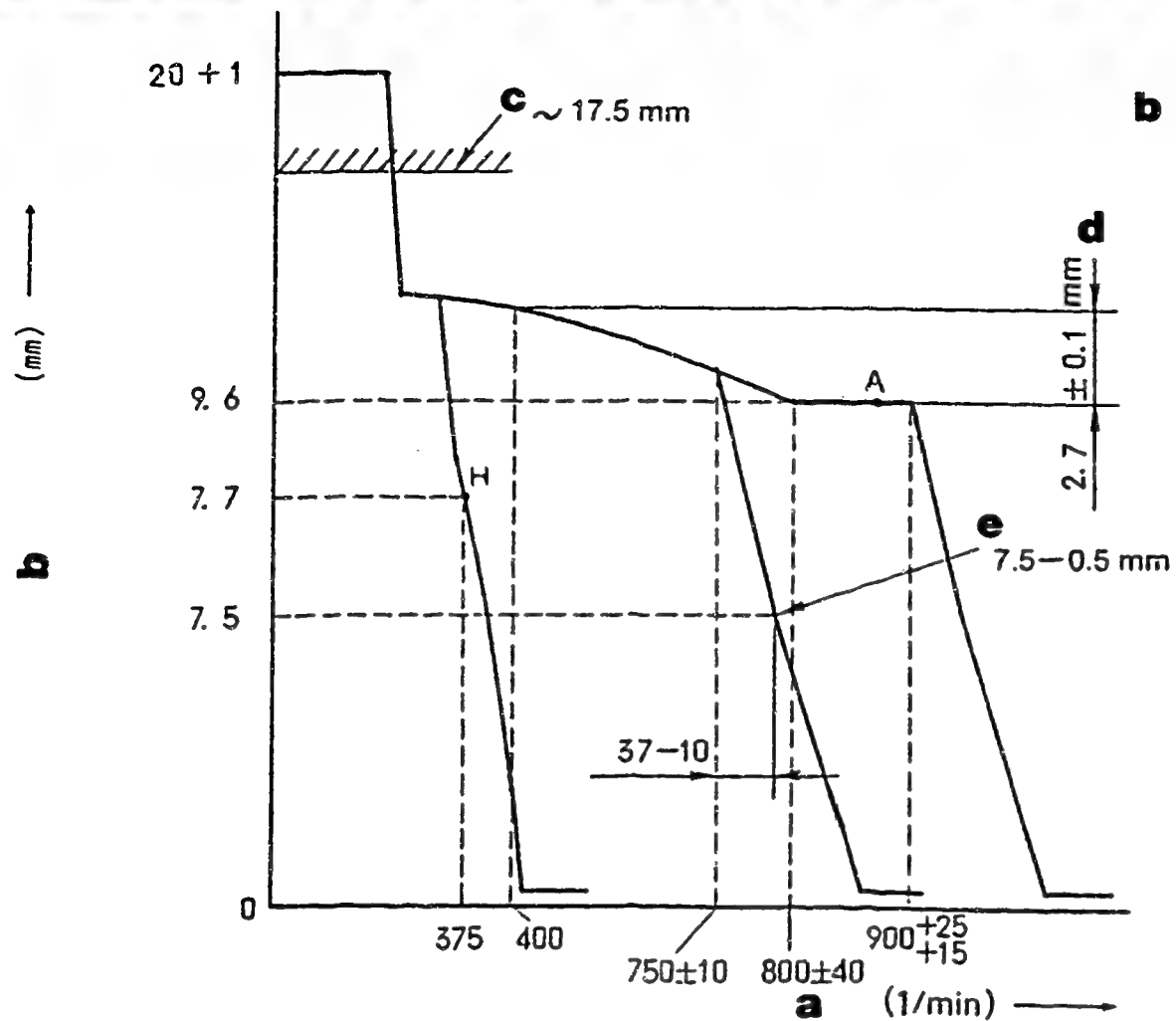

Figure 19

GOVERNOR ADJUSTMENT

101492-3540 2/4

Recommended speed droop adjustment screw position: above 12
Torque control spring setting: 0 N (0 kgf)

- a = Pump speed
- b = Control rack position
- c = Control rack limit:
- d = Difference in control rack position between 850 rpm and 400 rpm
- e = Idle-sub spring setting:

A = Speed Control Lever Angle

B = Stop Lever Angle

- a = Full-speed
- b = (on our shipment)
- c = Idling

- a = Stop
- b = Normal

■ TIMING SETTING

At No. 1 plunger's beginning of injection position.

a = Camshaft key groove position

■ Note

- Before adjustment, remove the idling sub spring.
- Move the control lever fully in the stop direction, and set the minimum-speed stopper bolt so that the control rack position is 0.5 - 1.0 mm.

■ ADJUSTMENT

		Pump Speed (rpm)	Rack Position (mm)	Boost pressure kPa (mmHg)	Remarks
Full-load Adjustment (Temporary)		1100 600	9.6 9.6		<ul style="list-style-type: none"> • Adjust using screw (2) • Adjust using screw (1)
Torque Control Spring Adjust- ment	1.st stroke	400 800±40	12.3 9.6		<ul style="list-style-type: none"> • Adjust using spring capsule (4) • Confirm • Confirm the torque control stroke is: 2.7±0.1 mm
	2.st stroke	-	-	-	<ul style="list-style-type: none"> • Adjust using spring capsule (4) • Confirm • Confirm the torque control stroke is: (mm)
Maximum Speed Adjustment		750±10 750+37 +27 900+25 +15	- 7.5 9.6		<ul style="list-style-type: none"> • Fix the control lever • Confirm speed droop - adjust using screw (3) • Confirm
Boost Compensator System		-	-	-	<ul style="list-style-type: none"> • Fix the control lever • Adjust using screw (6) • Confirm the boost compensator stroke is: (mm)
Idling Adjustment		750+37 +27	7.5 -0.5		<ul style="list-style-type: none"> • Fix the control lever • Adjust using spring capsule (5) • Confirm
2. Control Lever	H	375	7.7		<ul style="list-style-type: none"> • Adjust using the control lever
Full-load Adjustment		900	9.6		<ul style="list-style-type: none"> • Confirm
Control Lever Angle Measurement		<ul style="list-style-type: none"> • Measure the control lever angle at the "idling" and "full" positions. • When the control lever is depressed toward the "full" position, replace the shifter's shim with a thicker one. • When the control lever is depressed toward the "idling" position, replace the shifter's shim with a thinner one. 			
Control Rack Limiter Adjustment		0	approx. 17.5		<ul style="list-style-type: none"> • Adjust using screw

D 24

ZEXEL - Test values
Injection pumps



D 25

ZEXEL - Test values
Injection pumps



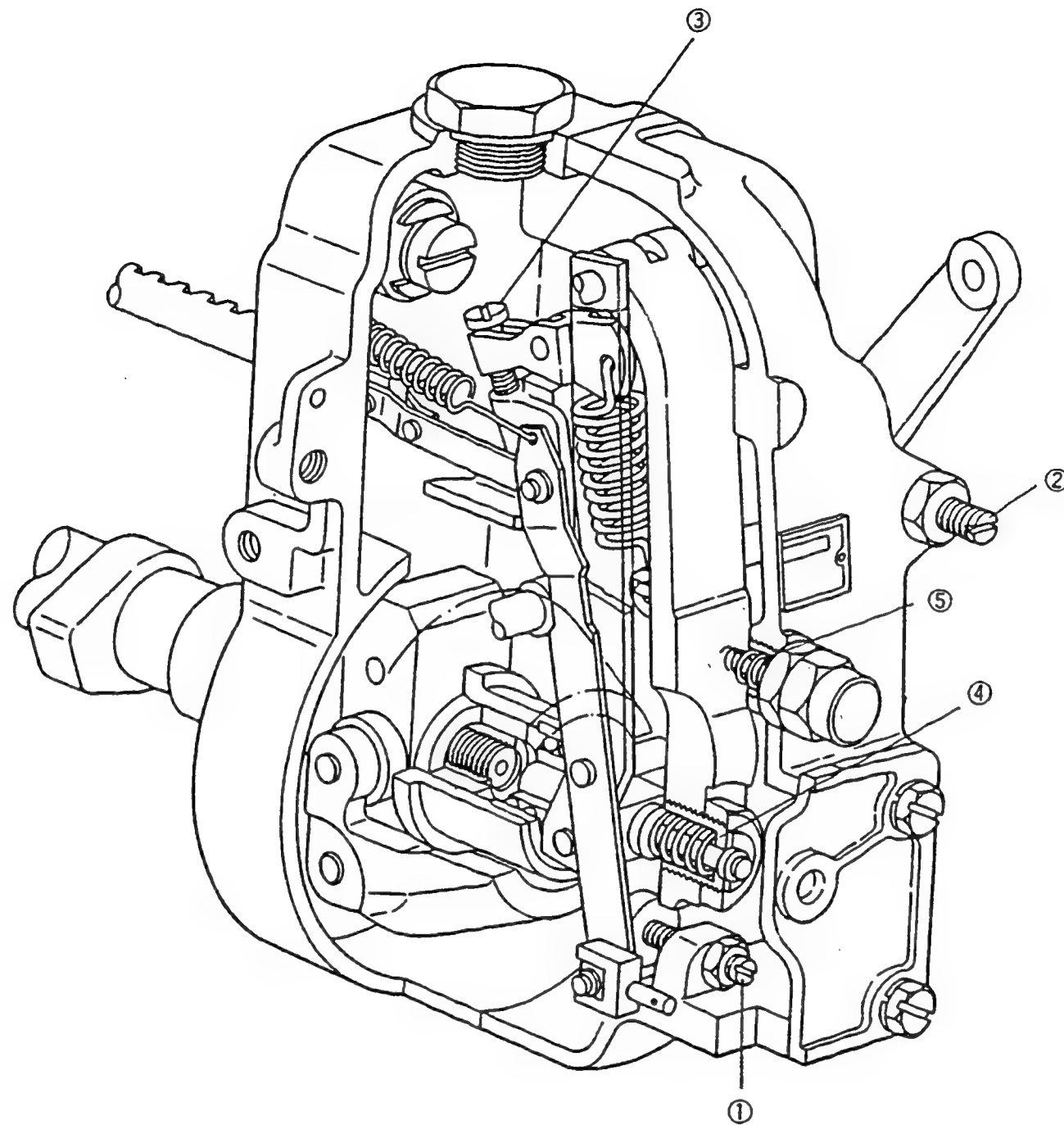

Figure 20

- 1 = Screw
- 2 = Screw
- 3 = Screw
- 4 = Spring capsule
- 5 = Spring capsule

101492-3540 4/4

D 26

ZEXEL - Test values
Injection pumps



D 27

ZEXEL - Test values
Injection pumps



ZEXEL - TEST VALUES
Injection pumps

BOSCH No.	:	9 400 610 195	1/4
ZEXEL No.	:	101492-3620	
Date	:	31.10.1992	[1]
Company	:	KOMATSU	
Engine	:	4D95L / 6204-71-1450	

IP-Type number	:	101049-8320 / PES4A
Governor type number	:	105400-4841 / EP/RSV

TEST PREREQUISITES

Test oil	:	ISO-4113
Test oil inlet temperature °C	:	40.00...45.00
Inlet pressure bar	:	1.6
Test nozzle holder combination	:	1 688 901 013
Opening pressure bar	:	175
Test pressure line	:	
Inner x Outer Dia - Length mm	:	2.00 x 6.00 x 600

PORT CLOSING

Prestroke	mm	:	3.6 ± 0.05
Rod position	mm	:	-
Port closing mark Cyl. No.	:	:	-
Cam sequence	:	:	1 - 2 - 4 - 3

Port closing mark Cyl. No.	:	:	-
Port closing difference °NW	:	:	0-90-180-270

Tolerance	+ - °C:	0.50 (0.75)
-----------	---------	-------------

E1

ZEXEL - Test values
Injection pumps



Injection Quantity :

Adjusting Point	Rack Pos. (mm)	P. Speed (rpm)	Injection Q'ty (cm ³ /1000 str.)	Difference (%)	Fixed	Remarks
A	9.6	850	36.5 ± 1.0	± 2.5	Rack	Basic
	approx. 8.2	375	6.2 ± 1.0	± 15.0	Rack	
A	9.6	850	36.5 ± 1.0	-	Lever	Basic

Timing Advance Specification :

Pump Speed (rpm)						
Advance Angle (deg)						

E2

ZEXEL - Test values

Injection pumps



E3

ZEXEL - Test values

Injection pumps



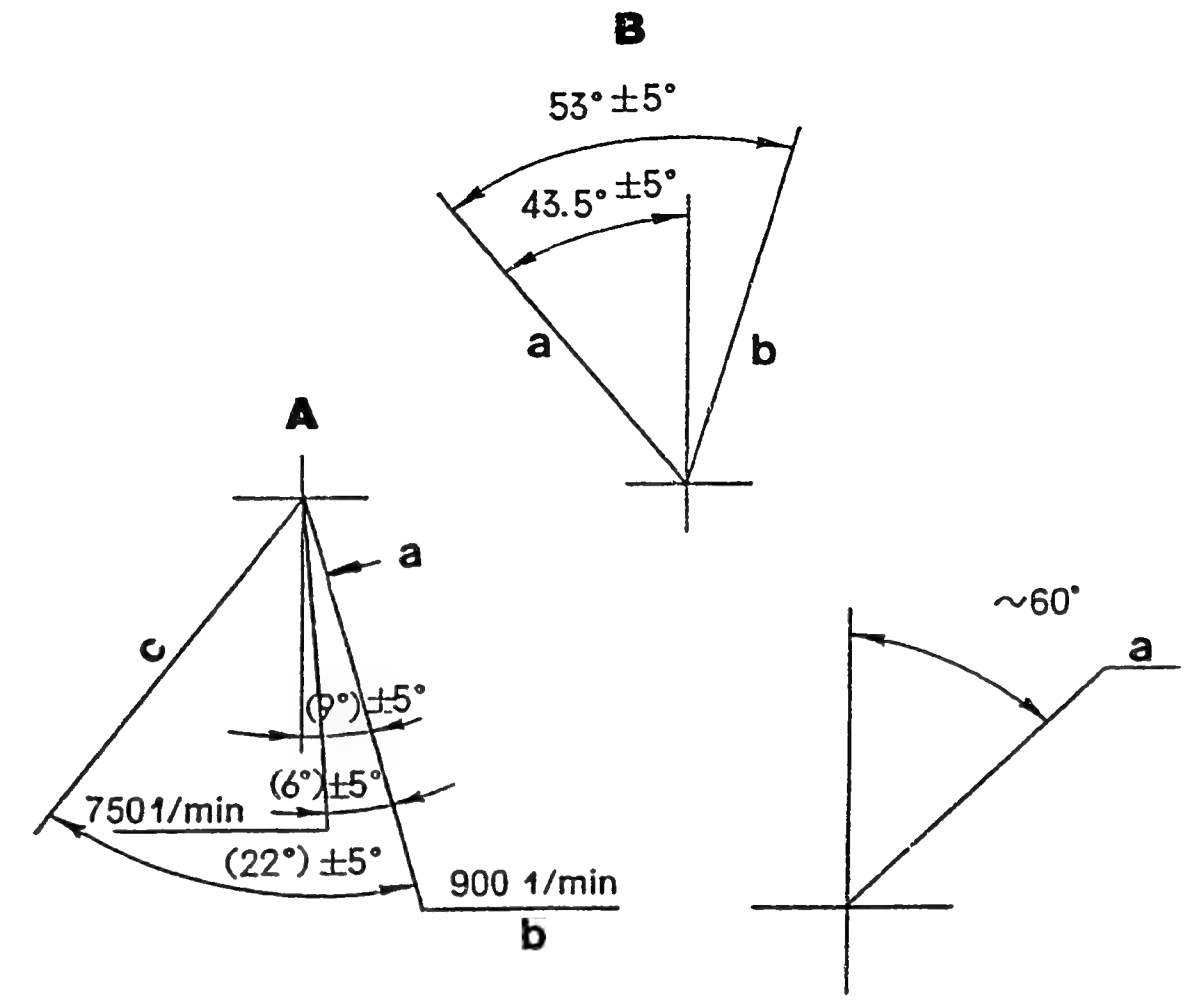
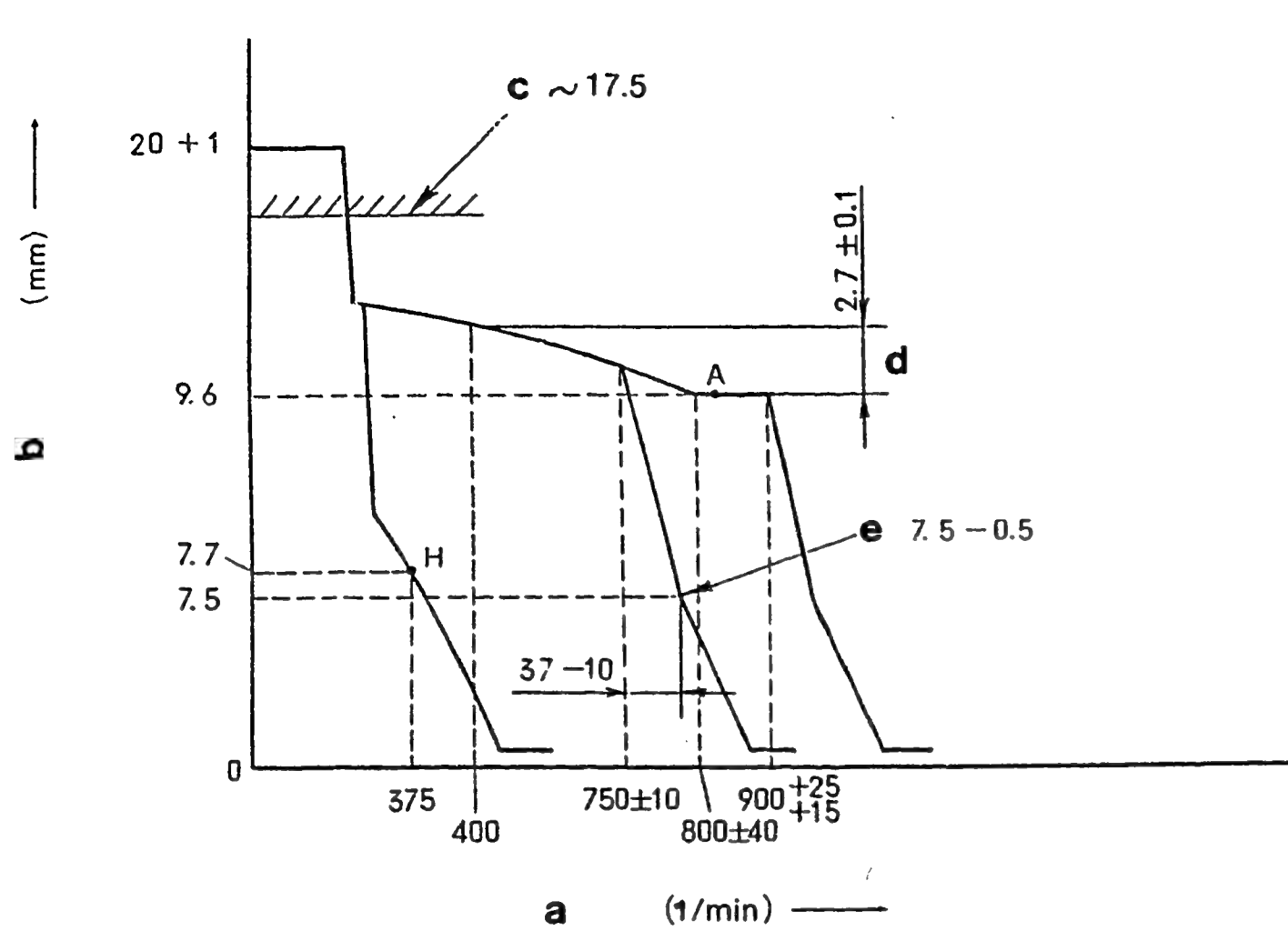

Figure 21

GOVERNOR ADJUSTMENT

Recommended speed droop adjustment screw position: above 12

- a = Pump speed
- b = Control rack position
- c = Control rack limit:
- d = Difference in control rack position between 850 rpm and 400 rpm
- e = Idle-sub spring setting:

- A = Speed Control Lever Angle
- a = Full-speed
- b = (on our shipment)
- c = Idling

- B = Stop Lever Angle
- a = Normal
- b = Stop

■ TIMING SETTING

At No. 1 plunger's beginning of injection position.

a = Camshaft key groove position

■ Note

- Before adjustment, remove the idling sub spring.
- Move the control lever fully in the stop direction, and set the minimum-speed stopper bolt so that the control rack position is 0.5 - 1.0 mm.

■ ADJUSTMENT

		Pump Speed (rpm)	Rack Position (mm)	Boost pressure kPa (mmHg)	Remarks
Full-load Adjustment (Temporary)		1100 600	9.6 9.6		<ul style="list-style-type: none"> • Adjust using screw (2) • Adjust using screw (1)
Torque Control Spring Adjust- ment	1.st stroke	400 800±40	12.3 9.6		<ul style="list-style-type: none"> • Adjust using spring capsule (4) • Confirm • Confirm the torque control stroke is: 2.7±0.1 mm
	2.st stroke	-	-		<ul style="list-style-type: none"> • Adjust using spring capsule (4) • Confirm • Confirm the torque control stroke is: (mm)
Maximum Speed Adjustment		750±10 777 - 787	- 7.5		<ul style="list-style-type: none"> • Fix the control lever • Confirm speed droop - adjust using screw (3) • Confirm
		915 - 925	9.6		<ul style="list-style-type: none"> • Fix the control lever • Confirm speed droop - adjust using screw (3)
Boost Compensator System		-	-		<ul style="list-style-type: none"> • Adjust using screw (6) • Confirm the boost compensator stroke is: (mm)
Idling Adjustment		750+37	7.5		<ul style="list-style-type: none"> • Fix the control lever • Adjust using spring capsule (5)
1. Idling Sub Spring		+27			
2. Control Lever		375	7.7		<ul style="list-style-type: none"> • Adjust using the control lever
Full-load Adjustment		900	9.6		<ul style="list-style-type: none"> • Confirm
Control Lever Angle Measurement		<ul style="list-style-type: none"> • Measure the control lever angle at the "idling" and "full" positions. • When the control lever is depressed toward the "full" position, replace the shifter's shim with a thicker one. • When the control lever is depressed toward the "idling" position, replace the shifter's shim with a thinner one. 			
Control Rack Limiter Adjustment		0	approx. 17.5		<ul style="list-style-type: none"> • Adjust using screw

E6

ZEXEL - Test values

Injection pumps



E7

ZEXEL - Test values

Injection pumps



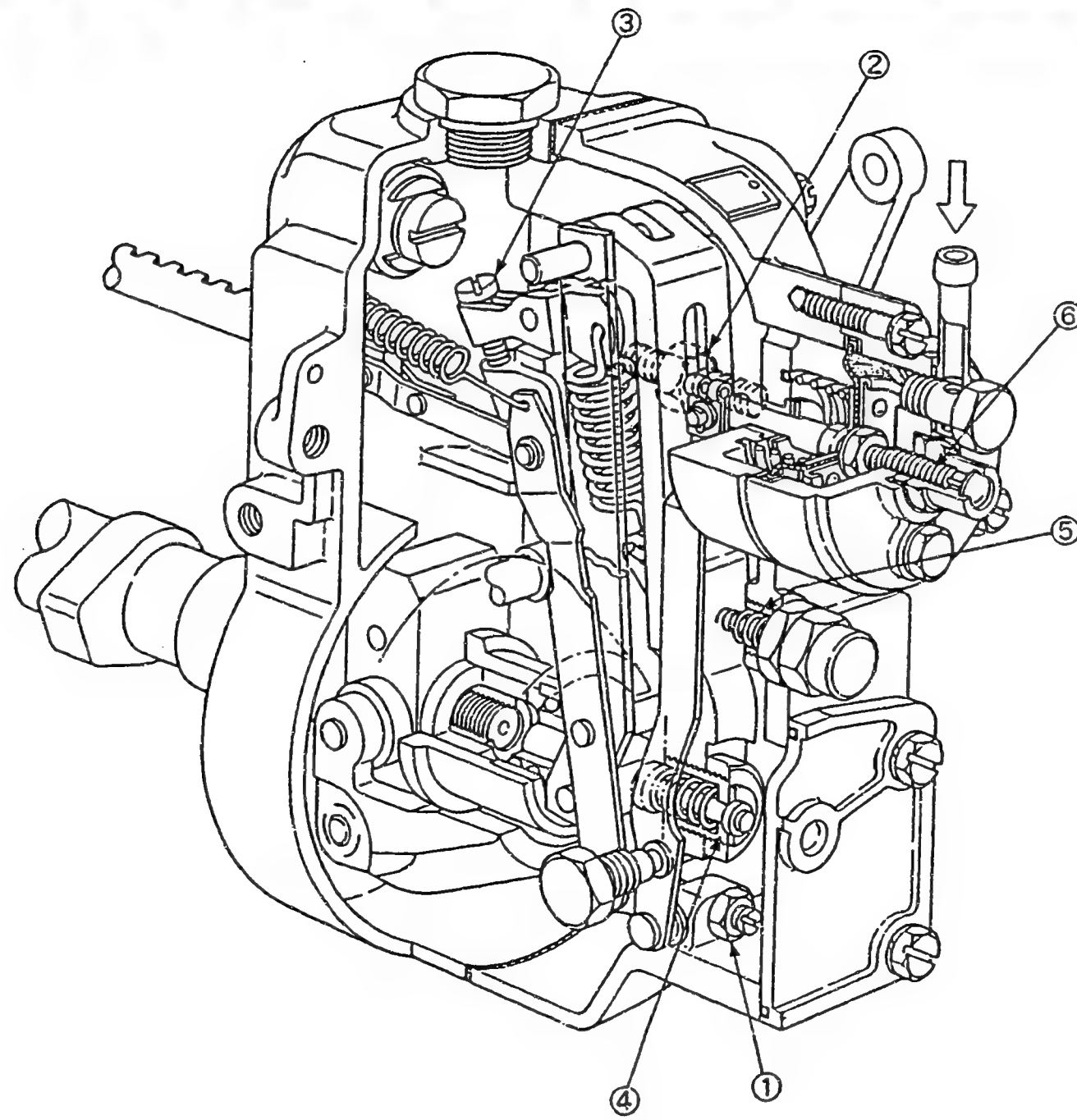

Figure 22

- 1 = Screw
- 2 = Screw
- 3 = Screw
- 4 = Spring capsule
- 5 = Spring capsule
- 6 = Screw

E8

ZEXEL - Test values
Injection pumps



E9

ZEXEL - Test values
Injection pumps



ZEXEL - TEST VALUES
Injection pumps

BOSCH No.	:	9 400 610 196	1/4
ZEXEL No.	:	101495-3200	
Date	:	31.10.1992	[0]
Company	:	KOMATSU	
Engine	:	4D95L / 6204-71-1431	

IP-Type number : 101049-8320 / PES4A
Governor type number : 105400-3741 / EP/RSV

TEST PREREQUISITES

Test oil : ISO-4113
Test oil inlet temperature °C : 40.00...45.00
Inlet pressure bar : 1.6
Test nozzle holder combination : 1 688 901 013
Opening pressure bar : 175
Test pressure line
Inner x Outer Dia - Length mm : 2.00 x 6.00 x 600

PORT CLOSING

Prestroke mm : 3.6 ± 0.05
Rod position mm : -
Port closing mark Cyl. No. : -
Cam sequence : 1 - 2 - 4 - 3

Port closing mark Cyl. No. : -
Port closing difference °NW : 0-90-180-270

Tolerance +- °C: 0.50 (0.75)

E10

ZEXEL - Test values
Injection pumps



Injection Quantity :

Adjusting Point	Rack Pos. (mm)	P. Speed (rpm)	Injection Q'ty (cm ³ /1000 str.)	Difference (%)	Fixed	Remarks
A	10.9	850	53.3 ± 1.0	± 2.5	Rack	Basic
	approx. 9.0	420	8.0 ± 1.0	± 15.0	Rack	
A	10.9	850	53.3 ± 1.0	-	Lever	Basic

Timing Advance Specification :

Pump Speed (rpm)						
Advance Angle (deg)						



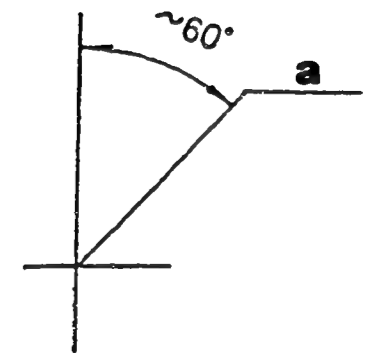
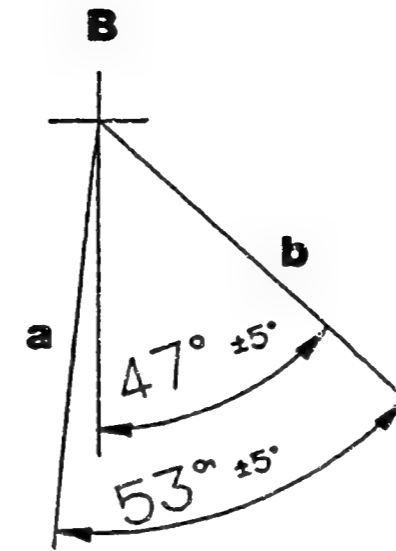
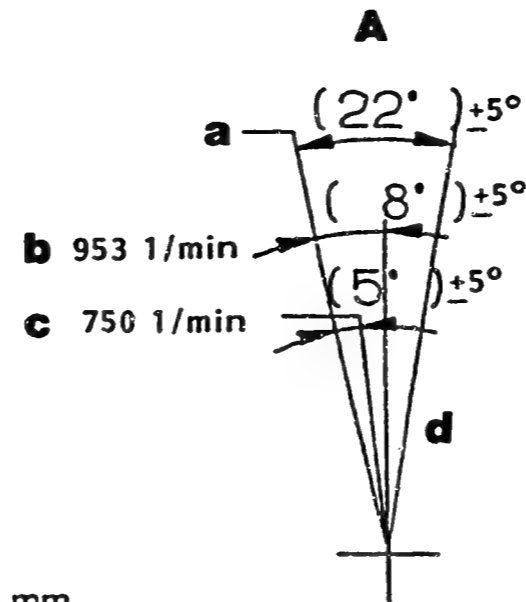
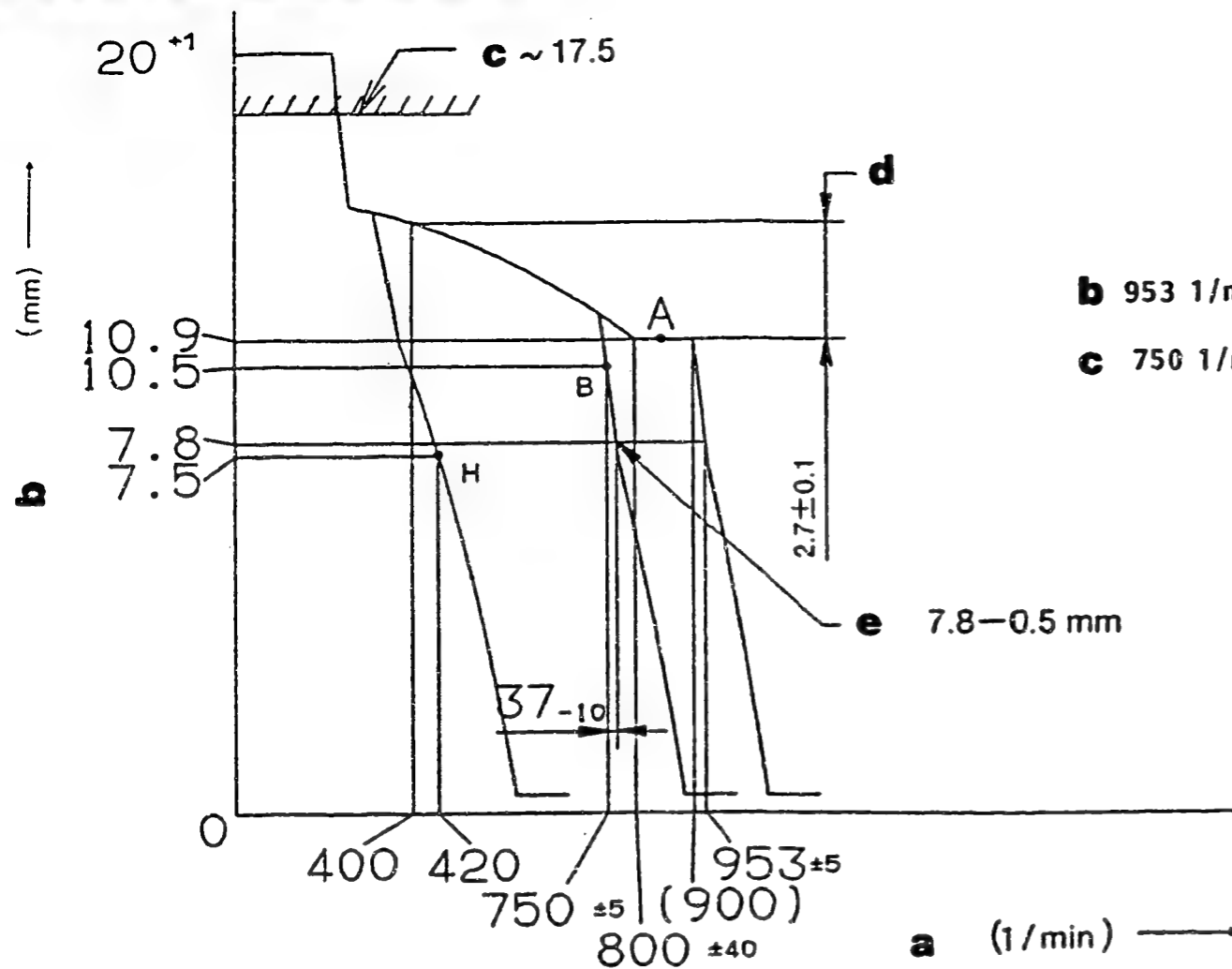

Figure 23

GOVERNOR ADJUSTMENT

Recommended speed droop adjustment screw position: 13
Torque control spring setting: 0 N (0 kgf)

101495-3200 2/4

- a = Pump speed
- b = Control rack position
- c = Control rack limit:
- d = Difference in control rack position between 850 rpm and 400 rpm
- e = Idle-sub spring setting:

A = Speed Control Lever Angle

- a = Full-speed
- b = Setting: (on our shipment)
- c = Setting:
- d = Idling

B = Stop Lever Angle

- a = Stop
- b = Normal

■ TIMING SETTING

At No. 1 plunger's beginning of injection position.

a = Camshaft key groove position

E13

ZEXEL - Test values
Injection pumps



E14

ZEXEL - Test values
Injection pumps



■ Note

- Before adjustment, remove the idling sub spring.
- Move the control lever fully in the stop direction, and set the minimum-speed stopper bolt so that the control rack position is 0.5 - 1.0 mm.

■ ADJUSTMENT

	Pump speed (rpm)	Rack position (mm)	Remarks
Full-load Adjustment (Temporary)	1100	10.9	<ul style="list-style-type: none"> • Adjust using screw (2) • Adjust using screw (1)
	600	10.9	
Torque Control spring Adjustment	400	13.6	<ul style="list-style-type: none"> • Adjust using spring capsule (4) • Confirm • Confirm the torque control stroke is 2.7 ± 0.1 mm
	800 ± 40	10.9	
Idling Adjustment	750^{+37} +27	$7.8 -0.5$	<ul style="list-style-type: none"> • Fix the control lever • Adjust using spring capsule (5) • Adjust using control lever
	420	7.5	
Maximum-speed Adjustment	approx. 900	10.9	<ul style="list-style-type: none"> • Fix the control lever • Confirm speed droop - adjust using screw (3) • Confirm
	953 ± 5	7.8	
Full-load Adjustment	900	10.9	<ul style="list-style-type: none"> • Adjust using screw (1)
Control Lever Angle Measurement	<ul style="list-style-type: none"> • Measure the control lever angle at the "idling" and "full" positions. • When the control lever is depressed toward the "full" position, replace the shifter's shim with a thicker one. • When the control lever is depressed toward the "idling" position, replace the shifter's shim with a thinner one. 		
Rack Limiter Adjustment	0	17.5	<ul style="list-style-type: none"> • Adjust using screw

E15

ZEXEL - Test values
Injection pumps



E16

ZEXEL - Test values
Injection pumps



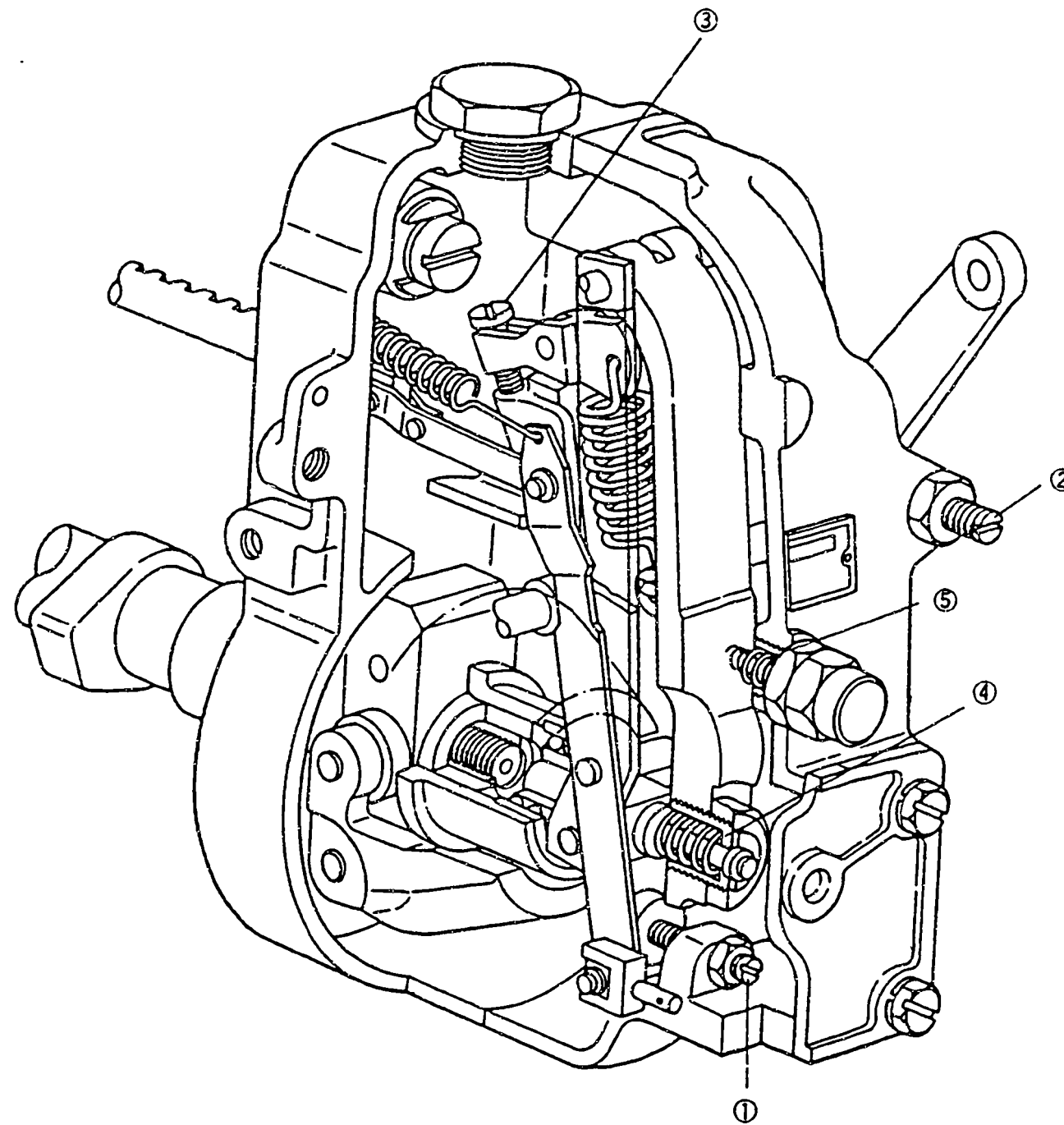

Figure 24

- 1 = Screw
- 2 = Screw
- 3 = Screw
- 4 = Spring capsule
- 5 = Spring capsule

E17

ZEXEL - Test values
Injection pumps



E18

ZEXEL - Test values
Injection pumps



ZEXEL - TEST VALUES
Injection pumps

BOSCH No.	:	9 400 610 197	1/4
ZEXEL No.	:	101601-3170	
Date	:	31.10.1992	[4]
Company	:	KOMATSU	
Engine	:	SA6D110 / 6138-72-1110	

IP-Type number : 101060-2700 / PE 6AD
Governor type number : 105411-0950 / EP/RSV

TEST PREREQUISITES

Test oil : ISO-4113
Test oil inlet temperature °C : 40.00...45.00
Inlet pressure bar : 1.6
Test nozzle holder combination : 1 688 901 013
Opening pressure bar : 175
Test pressure line
Inner x Outer Dia - Length mm : 2.00 x 6.00 x 600

PORT CLOSING

Prestroke mm : 4.0 ± 0.05
Rod position mm : -
Port closing mark Cyl. No. : -
Cam sequence : 1-5-3-6-2-4

Port closing mark Cyl. No. : -
Port closing difference °NW : 0-60-120-180-240-300

Tolerance +- °C: 0.50 (0.75)



Injection Quantity :

Adjusting Point	Rack Pos. (mm)	P. Speed (rpm)	Injection Q'ty (cm ³ /1000 str.)	Difference (%)	Fixed	Remarks
A	10.5	1100	85.8 ± 1.0	± 2.0	Rack	Basic
H	approx. 7.4	375	15.5 ± 1.2	± 10.0	Rack	
A	10.5	1100	85.8 ± 1.0	-	Lever	Basic Boost press. kPa (mmHg) above 40.7 (above 300)

Timing Advance Specification : EP/SA
105614-3070

Pump Speed (rpm)	Below 750	700	900	1100	
Advance Angle (deg)	Start	Below 0.5	1.4 ± 0.5	2.8 ± 0.5	Finish 5.0 ± 0.5

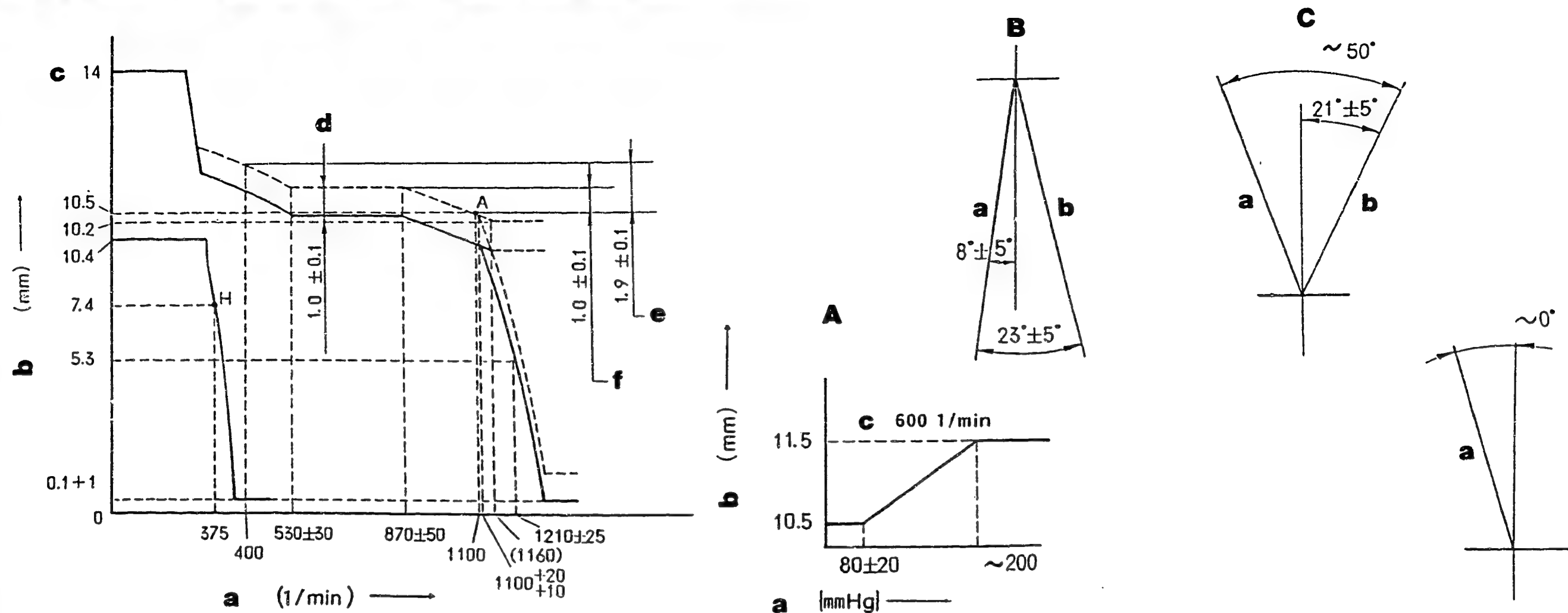

Figure 25 GOVERNOR ADJUSTMENT

Recommended speed droop adjustment screw position: 16

101601-3170 2/4

- a = Pump speed
- b = Control rack position
- c = Above
- d = Boost compensator stroke
- e = Difference in control rack position between 1100 rpm and 400 rpm
- f = Difference in control rack position between 1100 rpm and 750 rpm

- A = BOOST COMPENSATOR ADJUSTMENT
- a = Boost pressure
- b = Control rack position
- c = Perform at:
- B = Speed Control Lever Angle
- a = Full-speed
- b = Idling
- C = Stop Lever Angle
- a = Normal
- b = Stop

- TIMING SETTING
- At No. 1 plunger's beginning of injection position.
- a = Coupling key groove position

E22

ZEXEL - Test values
Injection pumps



E23

ZEXEL - Test values
Injection pumps



■ Note

- Before adjustment, remove the idling sub spring.
- Move the control lever fully in the stop direction, and set the minimum-speed stopper bolt so that the control rack position is 0.5 - 1.0 mm.

■ ADJUSTMENT

		Pump Speed (rpm)	Rack Position (mm)	Boost pressure kPa (mmHg)	Remarks
Full-load Adjustment (Temporary)		1300 600	10.2 10.2		<ul style="list-style-type: none"> • Adjust using screw (2) • Adjust using screw (1)
Torque Control Spring Adjust- ment	1.st stroke	400 500 - 560	12.4 11.5		<ul style="list-style-type: none"> • Adjust using spring capsule (4) • Confirm • Confirm the torque control stroke is: 0.9 ± 0.1 mm
	2.st stroke	approx. 770 870 \pm 50 1100 approx. 1160	11.5 11.5 10.5 10.2		<ul style="list-style-type: none"> • Adjust using spring capsule (4) • Confirm • Confirm • Confirm the torque control stroke is: 1.3 ± 0.1 mm
Maximum Speed Adjustment		1100 1210 \pm 25	10.5 5.3		<ul style="list-style-type: none"> • Fix the control lever • Confirm speed droop - adjust using screw (3) • Confirm
Boost Compensator System		600 600	10.5 11.5	10.7 \pm 2.7 (80 \pm 20) approx. 26.7 (approx. 200)	<ul style="list-style-type: none"> • Adjust using screw (6) • Confirm the boost compensator stroke is: 1.0 ± 0.1 mm
Idling Adjustment		0	10.4		<ul style="list-style-type: none"> • Fix the control lever • Adjust using spring capsule (5) • Confirm
1. Idling Sub Spring	H	375	7.4		<ul style="list-style-type: none"> • Adjust using spring capsule (5) • Confirm
2. Control Lever					<ul style="list-style-type: none"> • Adjust using the control lever
Full-load Adjustment		-	-		<ul style="list-style-type: none"> • Confirm
Control Lever Angle Measurement		<ul style="list-style-type: none"> • Measure the control lever angle at the "idling" and "full" positions. • When the control lever is depressed toward the "full" position, replace the shifter's shim with a thicker one. • When the control lever is depressed toward the "idling" position, replace the shifter's shim with a thinner one. 			
Control Rack Limiter Adjustment		-	-		<ul style="list-style-type: none"> • Adjust using screw

E24

ZEXEL - Test values
Injection pumps



E25

ZEXEL - Test values
Injection pumps



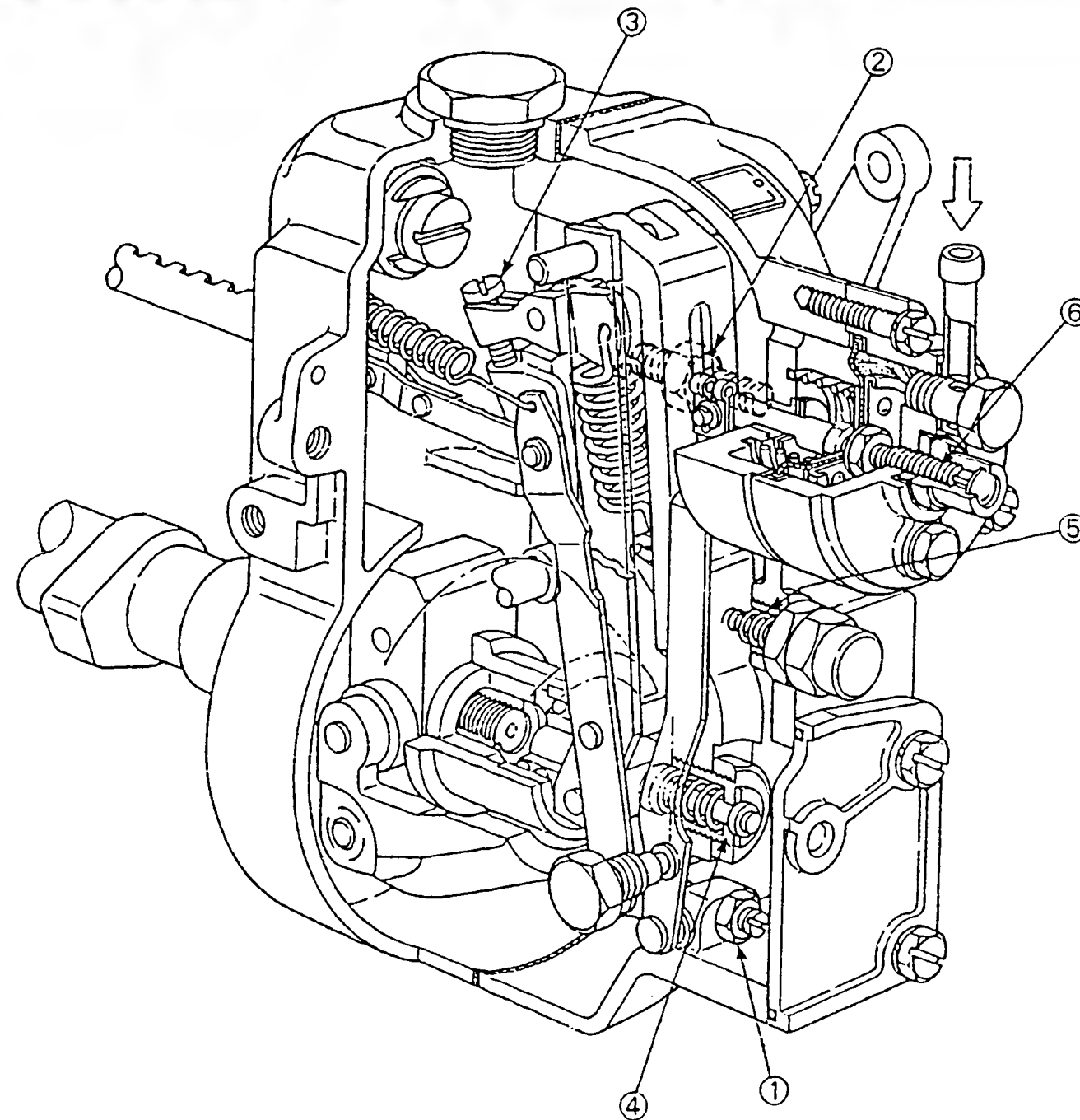

Figure 26

- 1 = Screw
- 2 = Screw
- 3 = Screw
- 4 = Spring capsule
- 5 = Spring capsule
- 6 = Screw

101601-3170 4/4

ZEXEL - TEST VALUES

Injection pumps

BOSCH No.	: 9 400 610 198	1/4
ZEXEL No.	: 101601-3370	
Date	: 31.10.1992	[6]
Company	: KOMATSU	
Engine	: SA6D110 / 6138-72-1320	

IP-Type number : 101060-2700 / PE 6AD
 Governor type number : 105411-1150 / EP/RSV

TEST PREREQUISITES

Test oil : ISO-4113
 Test oil inlet temperature °C : 40.00...45.00
 Inlet pressure bar : 1.6
 Test nozzle holder combination : 1 688 901 013
 Opening pressure bar : 175
 Test pressure line
 Inner x Outer Dia - Length mm : 2.00 x 6.00 x 600

PORT CLOSING

Prestroke mm : 4.0 ± 0.05
 Rod position mm : -
 Port closing mark Cyl. No. : -
 Cam sequence : 1-5-3-6-2-4

 Port closing mark Cyl. No. : -
 Port closing difference °NW : 0-60-120-180-240-300

 Tolerance +- °C: 0.50 (0.75)



Continued (Test values)

Injection Quantity :

Adjusting Point	Rack Pos. (mm)	P. Speed (rpm)	Injection Q'ty (cm ³ /1000 str.)	Difference (%)	Fixed	Remarks
A	10.7	1100	92.5 ± 1.0	± 2.0	Rack	Basic
H	approx. 7.4	375	15.5 ± 1.2	± 10.0	Rack	
A	10.7	1100	92.5 ± 1.0	-	Lever	Basic Boost press. kPa (mmHg) above 40.3 (above 300)
B	11.4	750	-	-	Lever	Boost press. kPa (mmHg) above 40.3 (above 300)

Timing Advance Specification : EP/SA
105614-3070

Pump Speed (rpm)	700	900	1100		
Advance Angle (deg)	Below 0.5	1.4 ± 0.5	2.8 ± 0.5	Finish 5.0 ± 0.5	

F2

ZEXEL - Test values
Injection pumps



F3

ZEXEL - Test values
Injection pumps



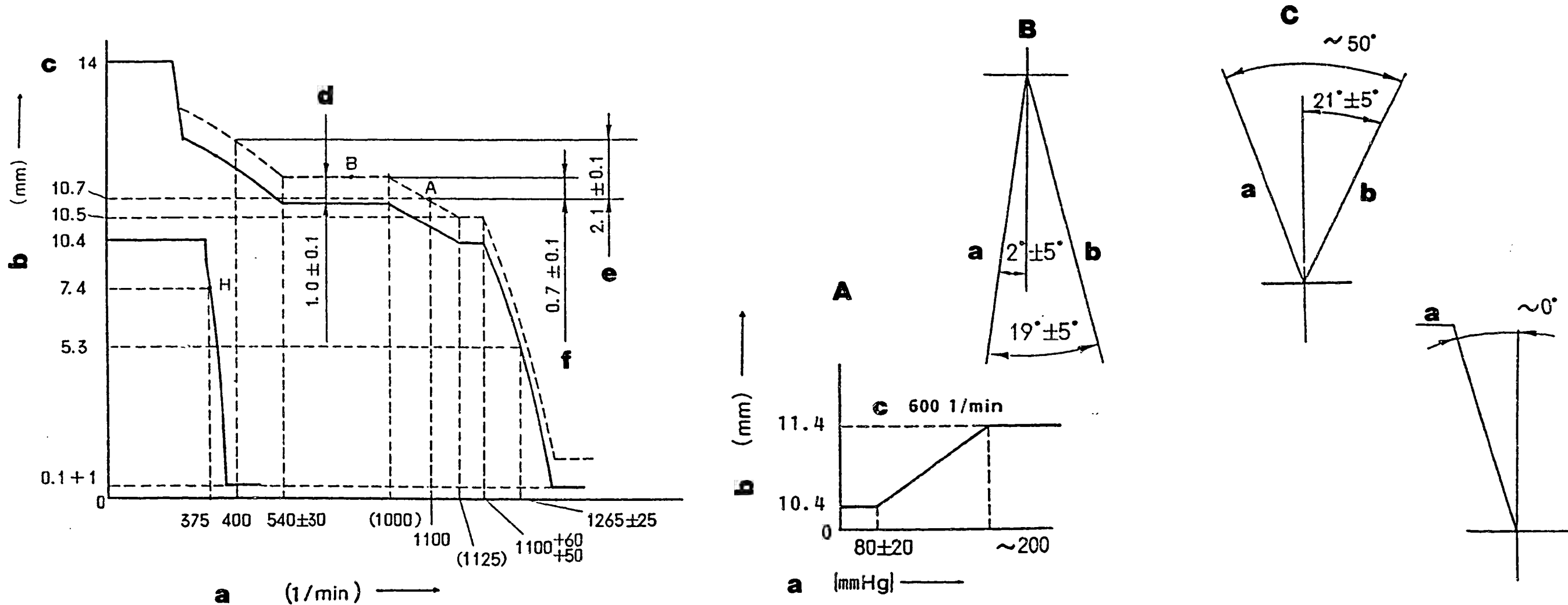

Figure 27 GOVERNOR ADJUSTMENT

- a = Pump speed
- b = Control rack position
- c = Above
- d = Boost compensator stroke
- e = Difference in control rack position between 1100 rpm and 400 rpm
- f = Difference in control rack position between 1100 rpm and 750 rpm

Recommended speed droop adjustment screw position: 10

101601-3370 2/4

A = BOOST COMPENSATOR ADJUSTMENT

- a = Boost pressure
- b = Control rack position
- c = Perform at:

B = Speed Control Lever Angle

- a = Full-speed
- b = Idling

C = Stop Lever Angle

- a = Normal
- b = Stop

■ TIMING SETTING

At No. 1 plunger's beginning of injection position.

a = Coupling key groove position

■ Note

- Before adjustment, remove the idling sub spring.
- Move the control lever fully in the stop direction, and set the minimum-speed stopper bolt so that the control rack position is 0.5 - 1.0 mm.

■ ADJUSTMENT

		Pump Speed (rpm)	Rack Position (mm)	Boost pressure kPa (mmHg)	Remarks
Full-load Adjustment (Temporary)		1300	10.5		• Adjust using screw (2)
		600	10.5		• Adjust using screw (1)
Torque Control Spring Adjust- ment	1.st stroke	400	12.8		• Adjust using spring capsule (4)
		540 ± 30	11.4		• Confirm the torque control stroke is: 1.4 ± 0.1 mm
	2.st stroke	approx. 900	11.4		• Adjust using spring capsule (4)
		1100	10.7		• Confirm
		approx. 1125	10.5		• Confirm the torque control stroke is: 0.9 ± 0.1 mm
Maximum Speed Adjustment		1100	10.5		• Fix the control lever
		1265 ± 25	5.3		• Confirm speed droop - adjust using screw (3)
					• Confirm
Boost Compensator System		600	10.4	10.7 ± 2.7 (80 ± 20)	• Adjust using screw (6)
		600	11.4	approx. 26.7 (approx. 200)	• Confirm the boost compensator stroke is: 1.0 ± 0.1 mm
Idling Adjustment		0	10.4		• Fix the control lever
1. Idling Sub Spring	H	375	7.4		• Adjust using spring capsule (5)
		above 400	0.1+1		• Confirm
2. Control Lever					• Adjust using the control lever
Full-load Adjustment		1100	10.5		• Confirm
Control Lever Angle Measurement		<ul style="list-style-type: none"> • Measure the control lever angle at the "idling" and "full" positions. • When the control lever is depressed toward the "full" position, replace the shifter's shim with a thicker one. • When the control lever is depressed toward the "idling" position, replace the shifter's shim with a thinner one. 			
Control Rack Limiter Adjustment		-	-		• Adjust using screw

F6

ZEXEL - Test values

Injection pumps



F7

ZEXEL - Test values

Injection pumps



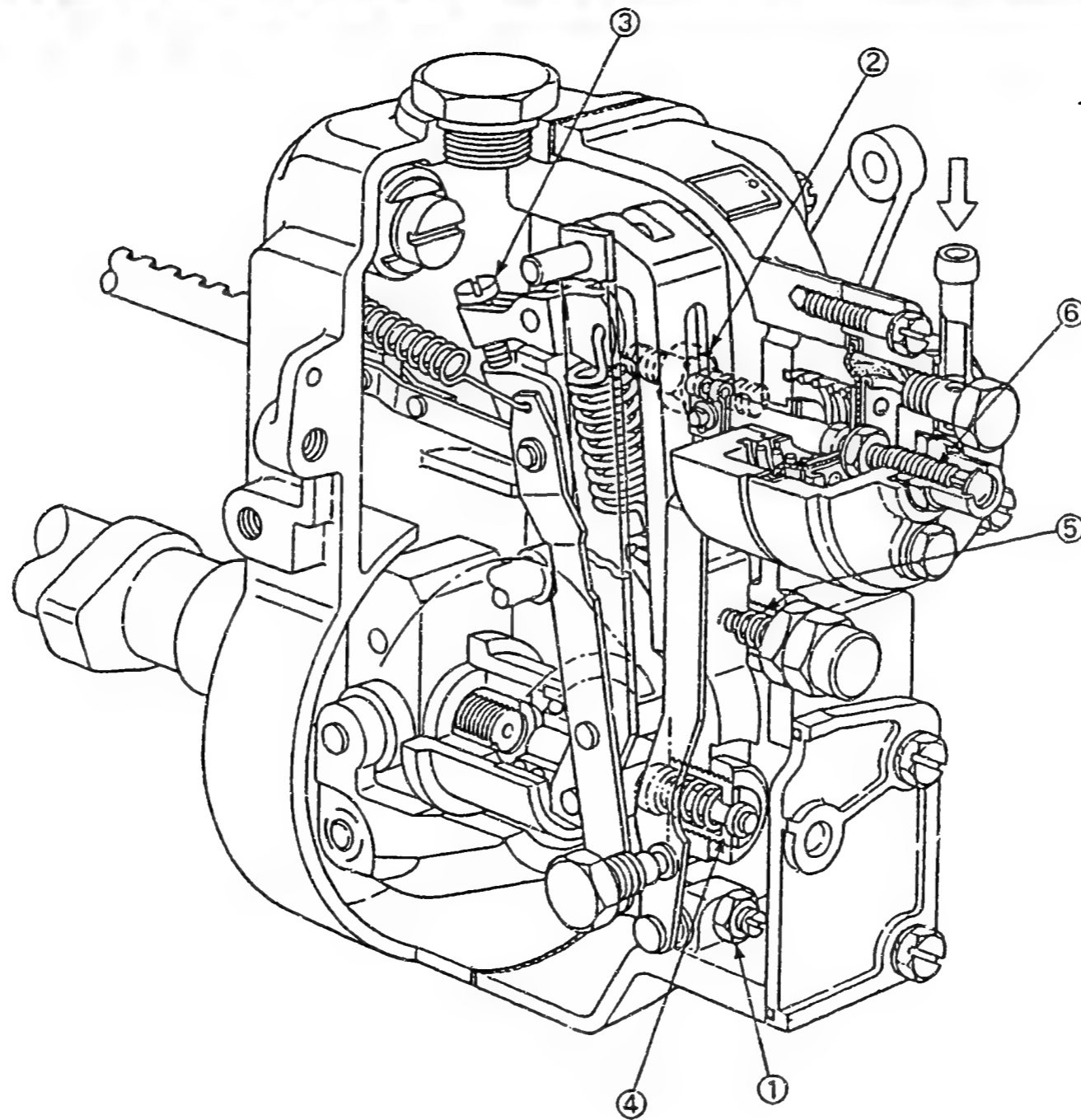

Figure 28

- 1 = Screw
- 2 = Screw
- 3 = Screw
- 4 = Spring capsule
- 5 = Spring capsule
- 6 = Screw

101601-3370 4/4

F8

ZEXEL - Test values
Injection pumps



F9

ZEXEL - Test values
Injection pumps



ZEXEL - TEST VALUES
Injection pumps

BOSCH No.	:	9 400 610 199	1/4
ZEXEL No.	:	101601-3382	
Date	:	31.10.1992	[6]
Company	:	KOMATSU	
Engine	:	SA6D110 / 6138-72-1310	

IP-Type number : 101060-2700 / PE 6AD
Governor type number : 105411-1161 / EP/RSV

TEST PREREQUISITES

Test oil : ISO-4113
Test oil inlet temperature °C : 40.00...45.00
Inlet pressure bar : 1.6
Test nozzle holder combination : 1 688 901 013
Opening pressure bar : 175
Test pressure line
Inner x Outer Dia - Length mm : 2.00 x 6.00 x 600

PORT CLOSING

Prestroke mm : 4.0 ± 0.05
Rod position mm : -
Port closing mark Cyl. No. : -
Cam sequence : 1-5-3-6-2-4

Port closing mark Cyl. No. : -
Port closing difference °NW : 0-60-120-180-240-300

Tolerance +- °C: 0.50 (0.75)

F10

ZEXEL - Test values
Injection pumps



Injection Quantity :

Adjusting Point	Rack Pos. (mm)	P. Speed (rpm)	Injection Q'ty (cm ³ /1000 str.)	Difference (%)	Fixed	Remarks
A	11.1	1100	(96.0 ± 1.0)	± 2.0	Rack	Basic
H	approx. 7.4	375	15.5 ± 1.2	± 10.0	Rack	
A	11.1	1100	(96.0 ± 1.0)	-	Lever	Basic Boost press. kPa (mmHg) above 41.3 (above 300)
B	11.8	750	-	-	Lever	Basic Boost press. kPa (mmHg) above 41.3 (above 300)

Timing Advance Specification : EP/SA
105614-3070

Pump Speed (rpm)	700	900	1100		
Advance Angle (deg)	Below 0.5	1.5 ± 0.5	3.2 ± 0.5	Finish 5.0 ± 0.5	

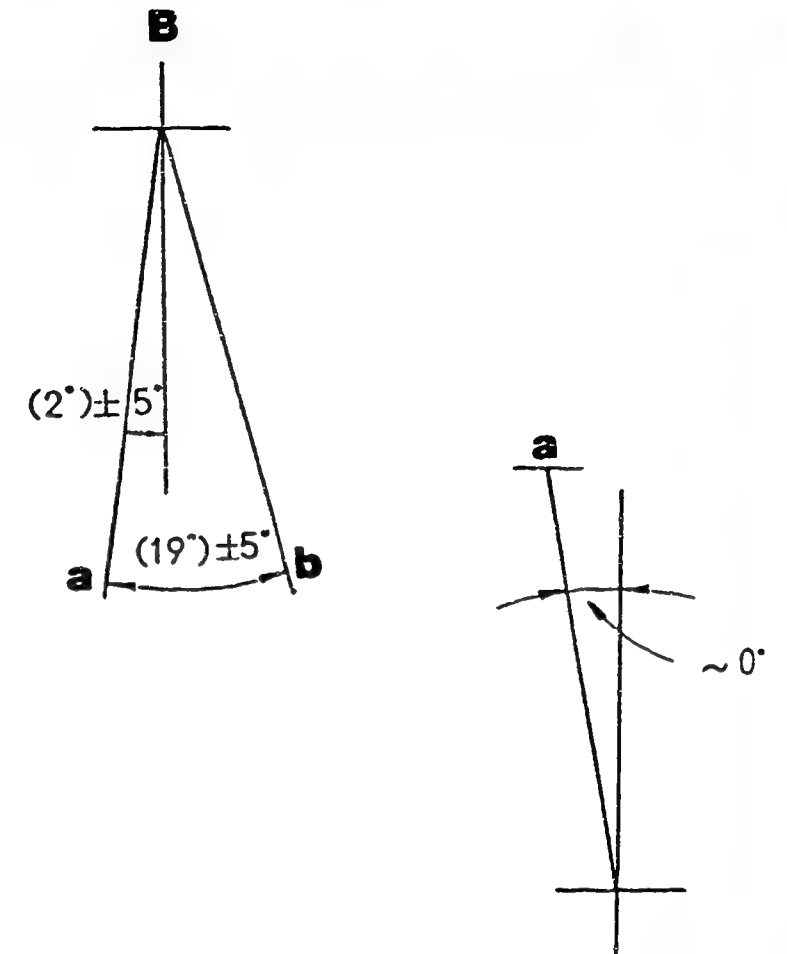
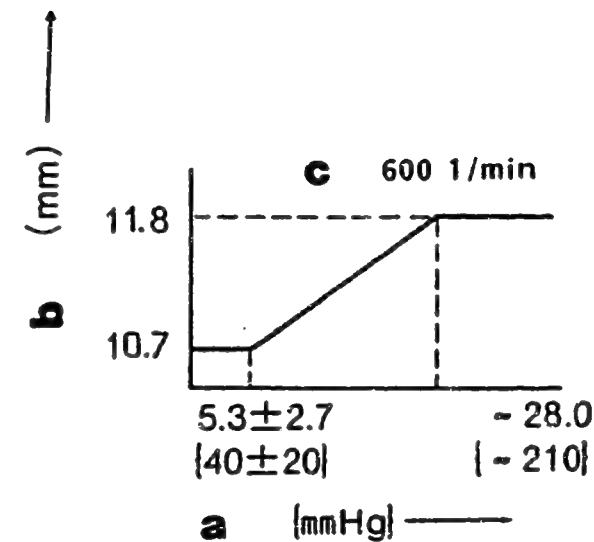
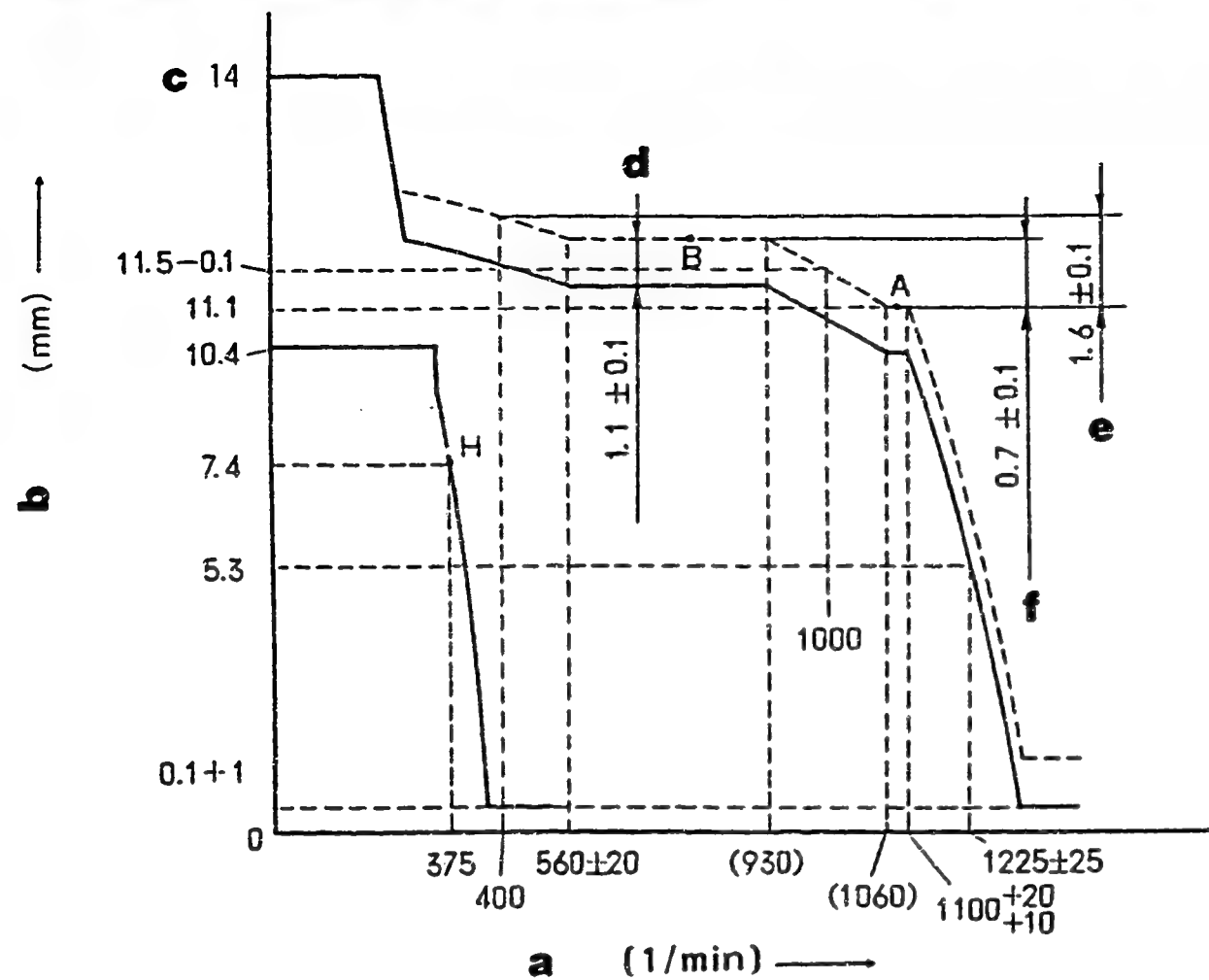

Figure 29 GOVERNOR ADJUSTMENT

Recommended speed droop adjustment screw position: 12

101601-3382 2/4

- a = Pump speed
- b = Control rack position
- c = Above
- d = Boost compensator stroke
- e = Difference in control rack position between 1100 rpm and 400 rpm
- f = Difference in control rack position between 1100 rpm and 750 rpm

- A = BOOST COMPENSATOR ADJUSTMENT
- a = Boost pressure
- b = Control rack position
- c = Perform at:
- B = Speed Control Lever Angle
- a = Full-speed
- b = Idling

■ TIMING SETTING

At No. 1 plunger's beginning of injection position.

a = Coupling key groove position

F13

ZEXEL - Test values
Injection pumps



F14

ZEXEL - Test values
Injection pumps



■ Note

- Before adjustment, remove the idling sub spring.
- Move the control lever fully in the stop direction, and set the minimum-speed stopper bolt so that the control rack position is 0.5 - 1.0 mm.

■ ADJUSTMENT

		Pump Speed (rpm)	Rack Position (mm)	Boost pressure kPa (mmHg)	Remarks
Full-load Adjustment (Temporary)		1300 600	11.1 11.1		<ul style="list-style-type: none"> • Adjust using screw (2) • Adjust using screw (1)
Torque Control Spring Adjust- ment	1.st stroke	400 560 ± 20	12.7 11.8		<ul style="list-style-type: none"> • Adjust using spring capsule (4) • Confirm • Confirm the torque control stroke is: 0.9 mm
	2.st stroke	approx. 830 1000	11.8 11.4		<ul style="list-style-type: none"> • Adjust using spring capsule (4) • Confirm • Confirm the torque control stroke is: 0.7 mm
		approx. 1060	11.1		
Maximum Speed Adjustment		1100+20 +10 1225±25	11.1 5.3		<ul style="list-style-type: none"> • Fix the control lever • Confirm speed droop - adjust using screw (3) • Confirm
Boost Compensator System		600 600	10.7 11.8	5.3 ± 2.7 (40 ± 20) approx. 28.0 (approx. 210)	<ul style="list-style-type: none"> • Adjust using screw (6) • Confirm the boost compensator stroke is: 1.1 ± 0.1 mm
Idling Adjustment	H	0 375 above 400	10.4 7.4 0.1+1		<ul style="list-style-type: none"> • Fix the control lever • Adjust using spring capsule (5) • Confirm
1. Idling Sub Spring					<ul style="list-style-type: none"> • Adjust using the control lever
2. Control Lever					
Full-load Adjustment		1100	11.1		<ul style="list-style-type: none"> • Confirm
Control Lever Angle Measurement		<ul style="list-style-type: none"> • Measure the control lever angle at the "idling" and "full" positions. • When the control lever is depressed toward the "full" position, replace the shifter's shim with a thicker one. • When the control lever is depressed toward the "idling" position, replace the shifter's shim with a thinner one. 			
Control Rack Limiter Adjustment		-	-		<ul style="list-style-type: none"> • Adjust using screw

F15

ZEXEL - Test values
Injection pumps



F16

ZEXEL - Test values
Injection pumps



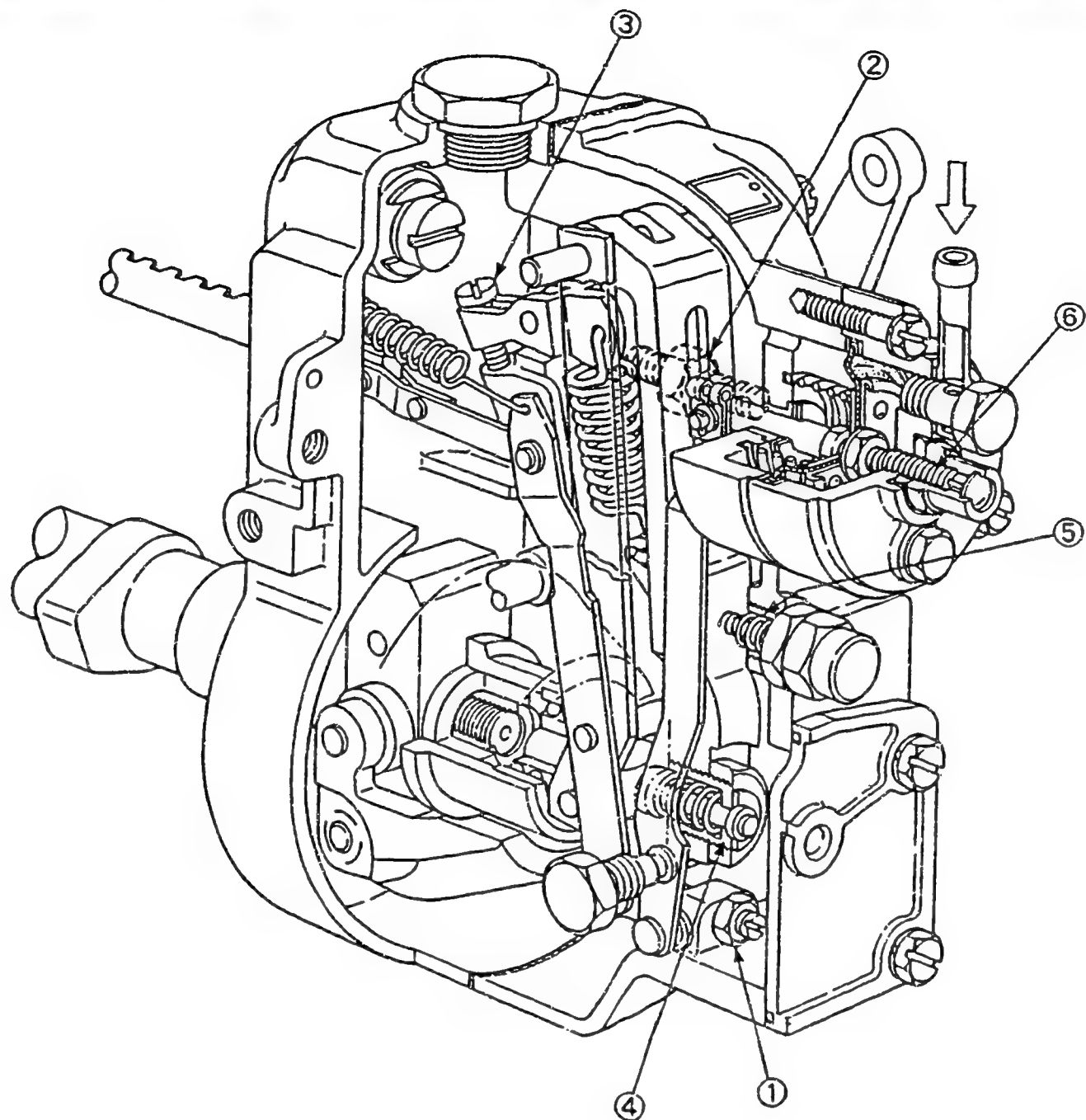

Figure 30
 1 = Screw
 2 = Screw
 3 = Screw
 4 = Spring capsule
 5 = Spring capsule
 6 = Screw

101601-3382 4/4

F17

ZEXEL - Test values
 Injection pumps



F18

ZEXEL - Test values
 Injection pumps



ZEXEL - TEST VALUES
Injection pumps

BOSCH No.	:	9 400 610 200	1/4
ZEXEL No.	:	101601-3451	
Date	:	31.10.1992	[2]
Company	:	KOMATSU	
Engine	:	SA6D110 / 6138-72-1311	

IP-Type number : 101060-2700 / PE 6AD
Governor type number : 105411-1361 / EP/RSV

TEST PREREQUISITES

Test oil : ISO-4113
Test oil inlet temperature °C : 40.00...45.00
Inlet pressure bar : 1.6
Test nozzle holder combination : 1 688 901 013
Opening pressure bar : 175
Test pressure line
Inner x Outer Dia - Length mm : 2.00 x 6.00 x 600

PORT CLOSING

Prestroke mm : 4.0 ± 0.05
Rod position mm : -
Port closing mark Cyl. No. : -
Cam sequence : 1-5-3-6-2-4

Port closing mark Cyl. No. : -
Port closing difference °NW : 0-60-120-180-240-300

Tolerance +- °C: 0.50 (0.75)

F19

ZEXEL - Test values
Injection pumps



Injection Quantity :

Adjusting Point	Rack Pos. (mm)	P. Speed (rpm)	Injection Q'ty (cm ³ /1000 str.)	Difference (%)	Fixed	Remarks
A	11.1	1100	(96.0 ± 1.0)	-	Rack	Basic
H	approx. 7.4	375	15.5 ± 1.2	-	Rack	
A	11.1	1100	(96.0 ± 1.0)	-	Lever	Basic Boost press. kPa (mmHg) above 41.3 (above 310)
B	11.8	750	-	-	Lever	Basic Boost press. kPa (mmHg) above 41.3 (above 310)

Timing Advance Specification : EP/SA
105614-3070

Pump Speed (rpm)	Below 750	700	900	1100	
Advance Angle (deg)	START	Below 0.5	1.5 ± 0.5	3.5 ± 0.5	Finish 2.95 ± 2.55

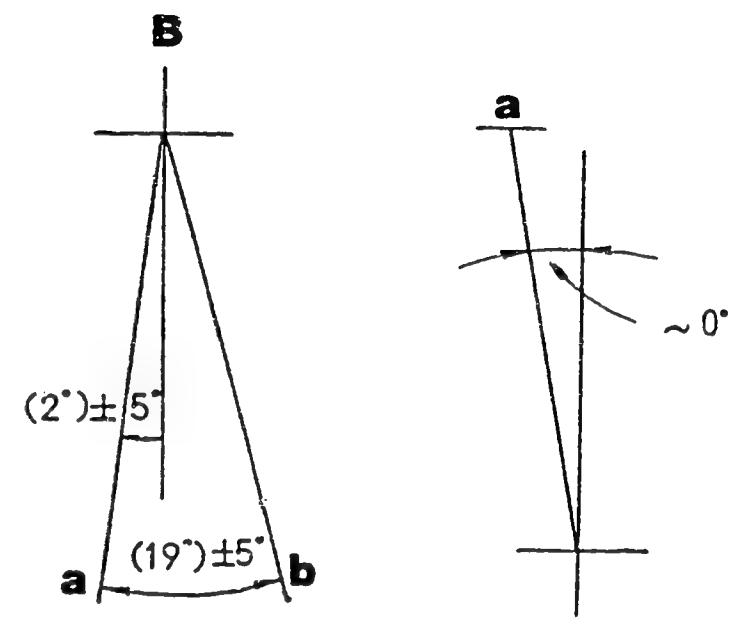
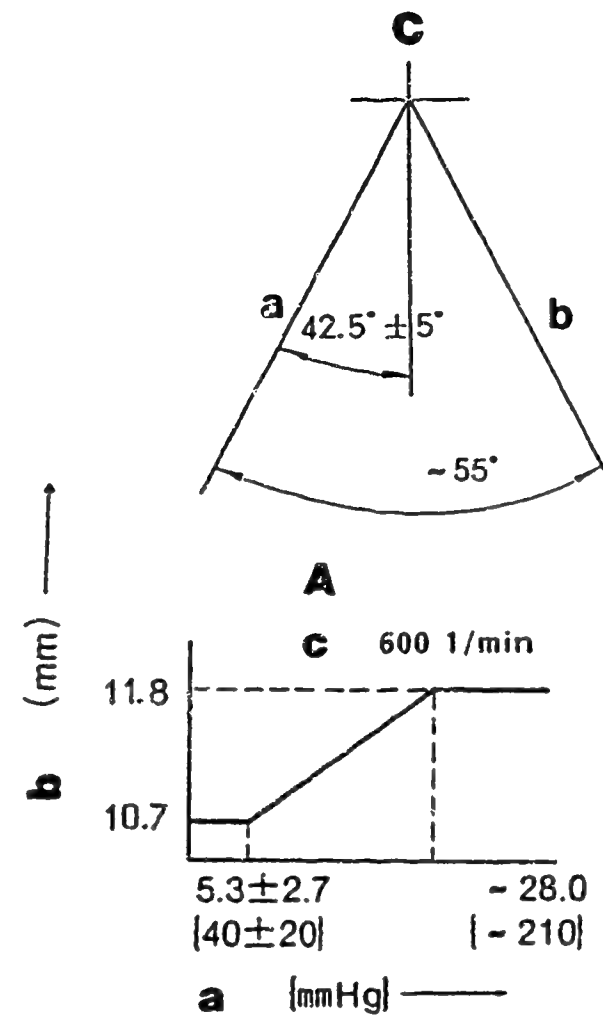
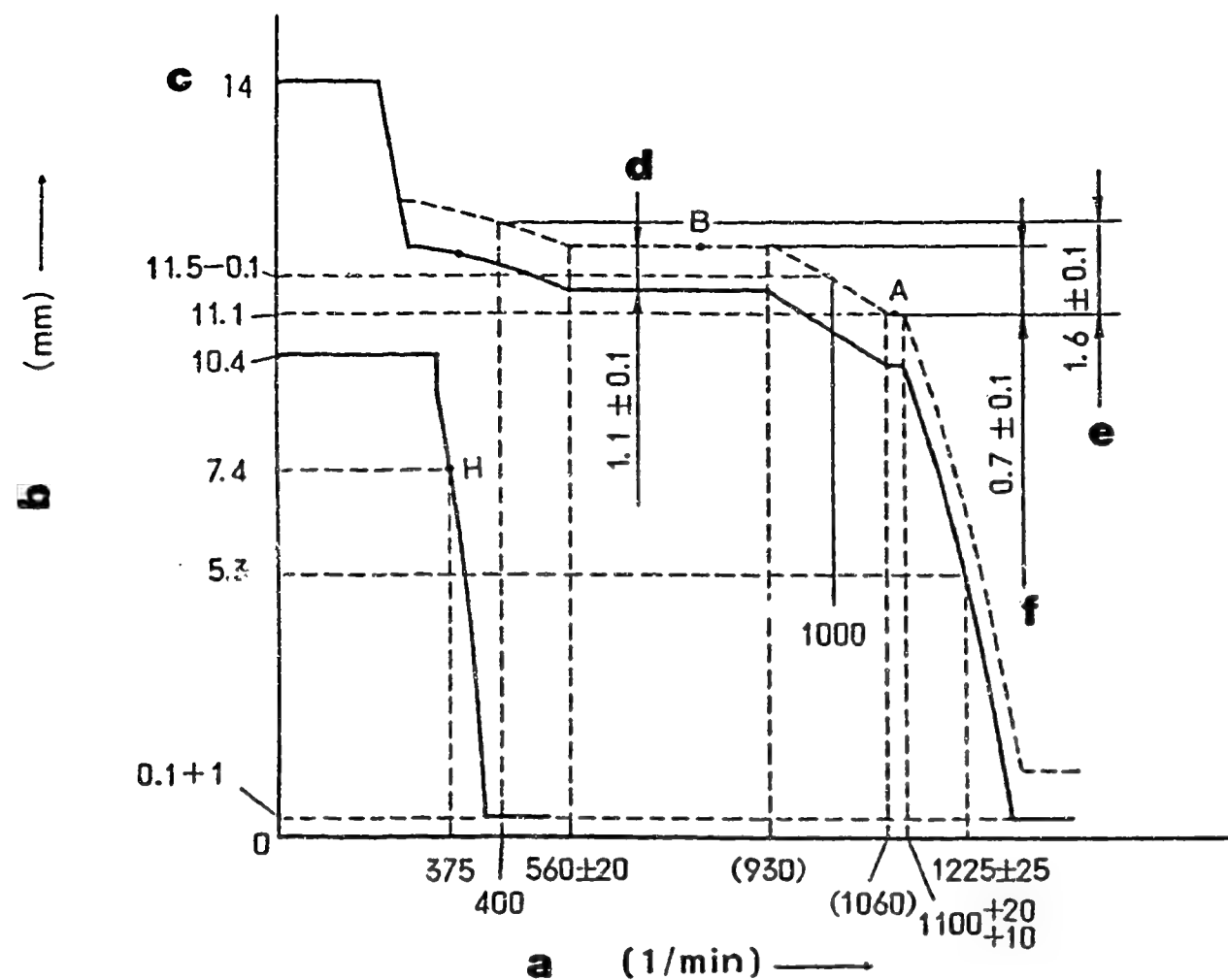

Figure 31 GOVERNOR ADJUSTMENT

- a = Pump speed
- b = Control rack position
- c = Above
- d = Boost compensator stroke
- e = Difference in control rack position between 1100 rpm and 400 rpm
- f = Difference in control rack position between 1100 rpm and 750 rpm

Recommended speed droop adjustment screw position: 12

101601-3451 2/4

A = BOOST COMPENSATOR ADJUSTMENT

- a = Boost pressure
- b = Control rack position
- c = Perform at:

B = Speed Control Lever Angle

- a = Full-speed
- b = Idling

C = Stop Lever Angle

- a = Stop
- b = Normal

■ TIMING SETTING

At No. 1 plunger's beginning of injection position.

a = Coupling key groove position

F22

ZEXEL - Test values
Injection pumps



F23

ZEXEL - Test values
Injection pumps



■ Note

- Before adjustment, remove the idling sub spring.
- Move the control lever fully in the stop direction, and set the minimum-speed stopper bolt so that the control rack position is 0.5 - 1.0 mm.

■ ADJUSTMENT

		Pump Speed (rpm)	Rack Position (mm)	Boost pressure kPa (mmHg)	Remarks
Full-load Adjustment (Temporary)		1300 600	11.1 11.1		<ul style="list-style-type: none"> • Adjust using screw (2) • Adjust using screw (1)
Torque Control Spring Adjust- ment	1.st stroke	400 560 ± 20	12.7 11.8		<ul style="list-style-type: none"> • Adjust using spring capsule (4) • Confirm • Confirm the torque control stroke is: 0.9 ± 0.1 mm
	2.st stroke	approx. 830	11.8		<ul style="list-style-type: none"> • Adjust using spring capsule (4) • Confirm • Confirm the torque control stroke is: 0.7 ± 0.1 mm
		approx. 930 approx. 1060	11.8 11.1		
Maximum Speed Adjustment		1100 1225 ± 25	11.1 5.3		<ul style="list-style-type: none"> • Fix the control lever • Confirm speed droop - adjust using screw (3) • Confirm
Boost Compensator System		600	5.3 ± 2.7 (40 ± 20)	10.7	<ul style="list-style-type: none"> • Adjust using screw (6)
		600	approx. 28.0 (approx. 210)	11.8	<ul style="list-style-type: none"> • Confirm the boost compensator stroke is: 1.1 ± 0.1 mm
Idling Adjustment	H	0	10.4		<ul style="list-style-type: none"> • Fix the control lever • Adjust using spring capsule (5) • Confirm
1. Idling Sub Spring		375 above 400	7.4 0.1+1		
2. Control Lever					
Full-load Adjustment		1100	11.1		<ul style="list-style-type: none"> • Confirm
Control Lever Angle Measurement		<ul style="list-style-type: none"> • Measure the control lever angle at the "idling" and "full" positions. • When the control lever is depressed toward the "full" position, replace the shifter's shim with a thicker one. • When the control lever is depressed toward the "idling" position, replace the shifter's shim with a thinner one. 			
Control Rack Limiter Adjustment		-	-		<ul style="list-style-type: none"> • Adjust using screw

F24

ZEXEL - Test values
Injection pumps



F25

ZEXEL - Test values
Injection pumps



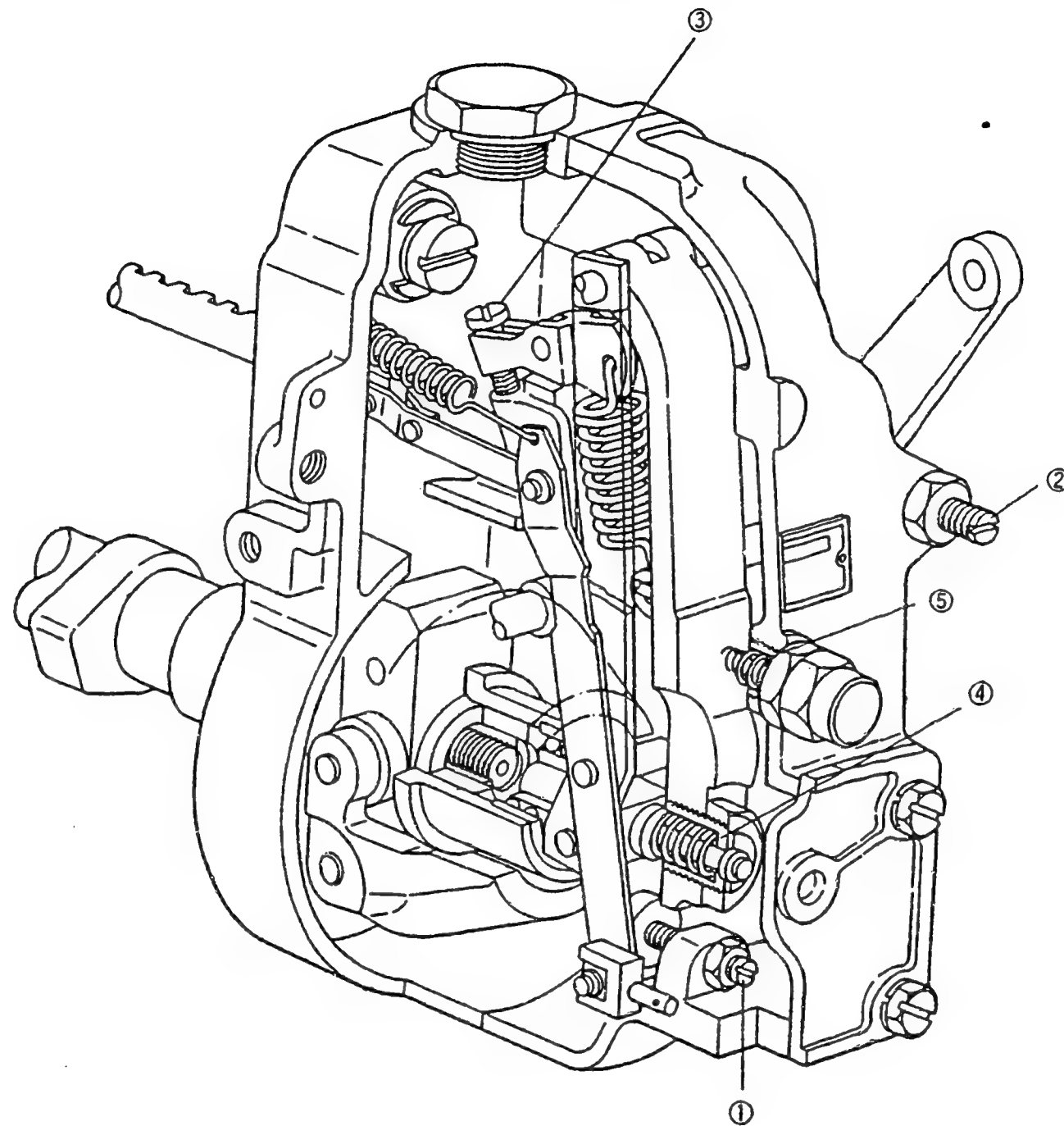

Figure 32

- 1 = Screw
- 2 = Screw
- 3 = Screw
- 4 = Spring capsule
- 5 = Spring capsule
- 6 = Screw

101601-3451 4/4

F26

ZEXEL - Test values
Injection pumps



F27

ZEXEL - Test values
Injection pumps



ZEXEL - TEST VALUES
Injection pumps

BOSCH No. : 9 400 610 201 1/4
ZEXEL No. : 101601-3540
Date : 31.10.1992 [0]
Company : KOMATSU
Engine : SA6D110 / 6135-72-1581

IP-Type number : 101060-2750 / PE 6AD
Governor type number : 105419-0330 / EP/RSV

TEST PREREQUISITES

Test oil : ISO-4113
Test oil inlet temperature °C : 40.00...45.00
Inlet pressure bar : 1.6
Test nozzle holder combination : 1 688 901 013
Opening pressure bar : 175
Test pressure line
Inner x Outer Dia - Length mm : 2.00 x 6.00 x 600

PORT CLOSING

Prestroke mm : 4.0 ± 0.05
Rod position mm : -
Port closing mark Cyl. No. : -
Cam sequence : 1-5-3-6-2-4
Port closing mark Cyl. No. : -
Port closing difference °NW : 0-60-120-180-240-300
Tolerance +- °C: 0.50 (0.75)

G1

ZEXEL - Test values
Injection pumps



Continued (Test values)

Injection Quantity :

Adjusting Point	Rack Pos. (mm)	P. Speed (rpm)	Injection Q'ty (cm ³ /1000 str.)	Difference (%)	Fixed	Remarks
A	10.5	1250	86.6 ± 1.0	± 2.0	Rack	Basic
H	approx. 7.4	400	13.2 ± 1.2	± 10.0	Rack	
A	10.5	1250	86.6 ± 1.0	-	Lever	Basic

Timing Advance Specification : 105614-3110

Pump Speed (rpm)	700	900	1150			
Advance Angle (deg)	Below 0.5	1.4 ± 0.5	Finish 3.5 ± 0.5			

G2

ZEXEL - Test values
Injection pumps



G3

ZEXEL - Test values
Injection pumps



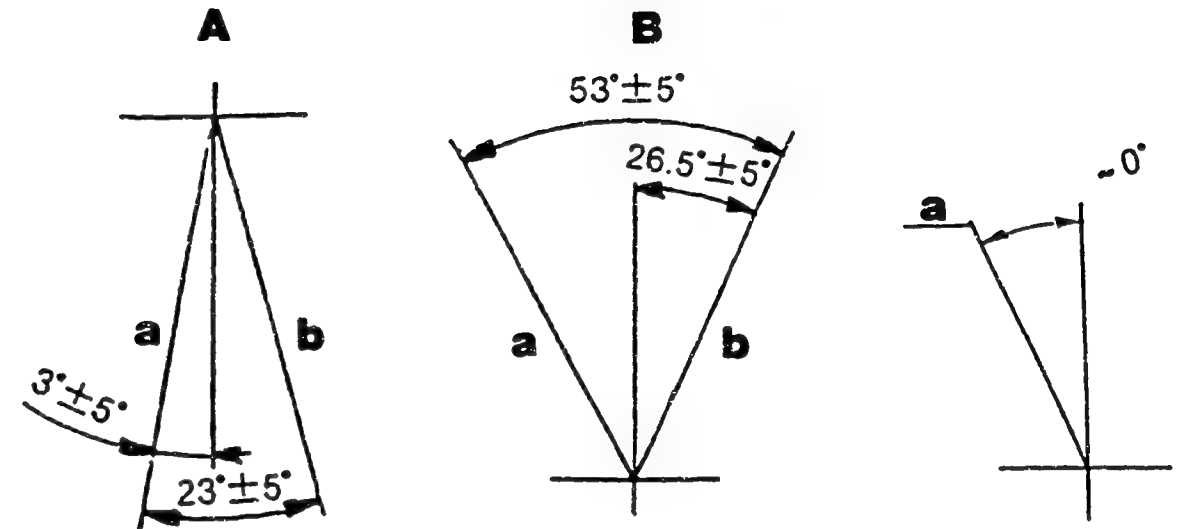
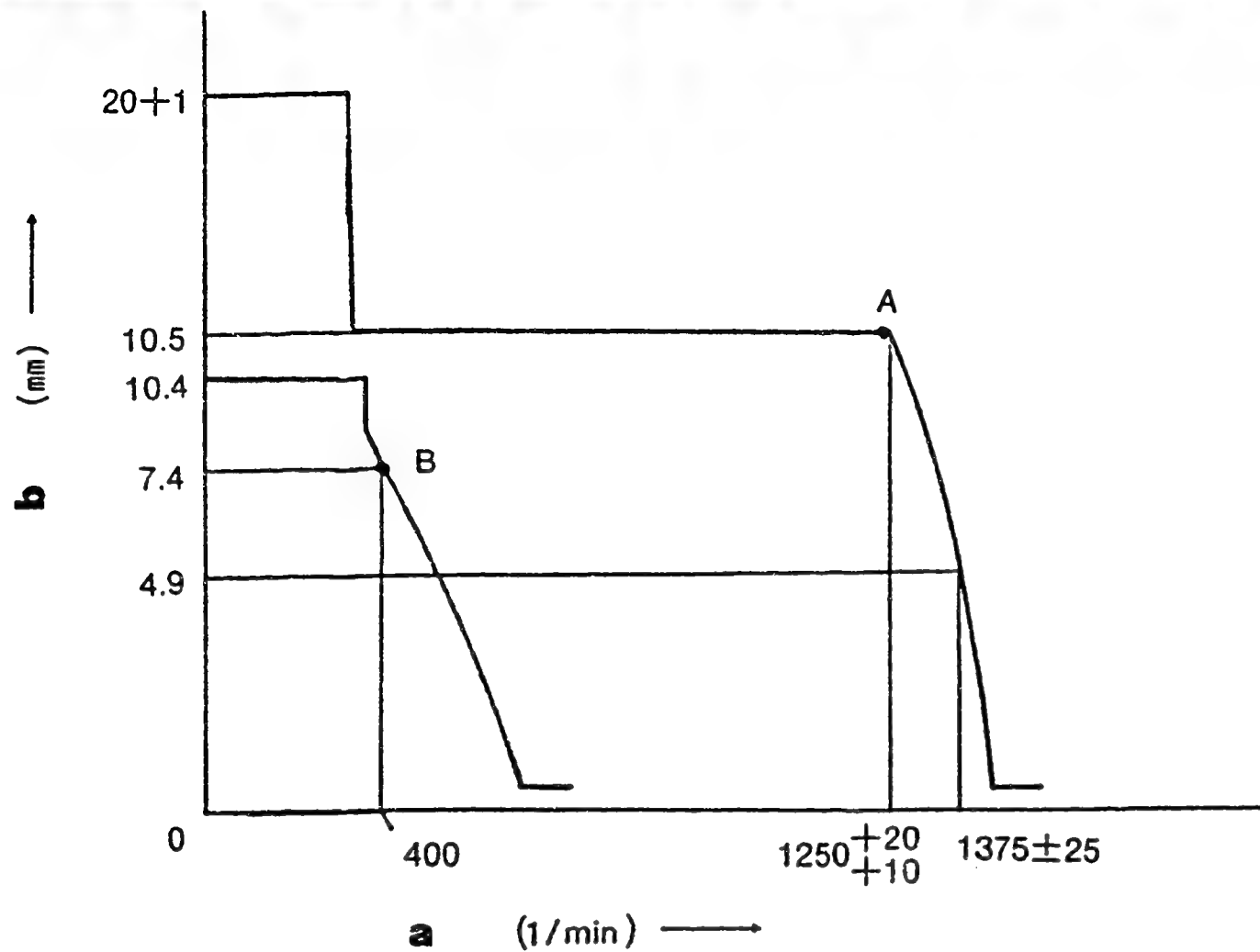

Figure 33

a = Pump speed
b = Control rack position

GOVERNOR ADJUSTMENT

Recommended speed droop adjustment screw position: 6
Perform torque control spring adjustment when necessary

101601-3540 2/4

A = Speed Control Lever Angle

a = Full-speed
b = Idling

B = Stop Lever Angle

a = Stop
b = Normal

TIMING SETTING

At No. 1 plunger's beginning of injection position.

a = Coupling key groove position

■ Note

- Before adjustment, remove the idling sub spring.
- Move the control lever fully in the stop direction, and set the minimum-speed stopper bolt so that the control rack position is 0.5 - 1.0 mm.

■ ADJUSTMENT

	Pump speed (rpm)	Rack position (mm)	Remarks
Full-load Adjustment (Temporary)	1350 600	10.5 10.5	<ul style="list-style-type: none"> • Adjust using screw (2) • Adjust using screw (1)
Torque Control spring Adjustment	-	-	<ul style="list-style-type: none"> • Adjust using spring capsule (4) • Confirm • Confirm the torque control stroke is: (mm)
Idling Adjustment	0 400	10.4 7.4	<ul style="list-style-type: none"> • Fix the control lever • Adjust using spring capsule (5) • Confirm
Maximum-speed Adjustment	1250+20 +10 1375 ± 25	10.5 4.9	<ul style="list-style-type: none"> • Fix the control lever • Confirm speed droop - adjust using screw (3) • Confirm
Full-load Adjustment	1250	10.5	<ul style="list-style-type: none"> • Adjust using screw (1)
Control Lever Angle Measurement	<ul style="list-style-type: none"> • Measure the control lever angle at the "idling" and "full" positions. • When the control lever is depressed toward the "full" position, replace the shifter's shim with a thicker one. • When the control lever is depressed toward the "idling" position, replace the shifter's shim with a thinner one. 		
Rack Limiter Adjustment	-	-	<ul style="list-style-type: none"> • Adjust using screw

G6

ZEXEL - Test values
Injection pumps



G7

ZEXEL - Test values
Injection pumps



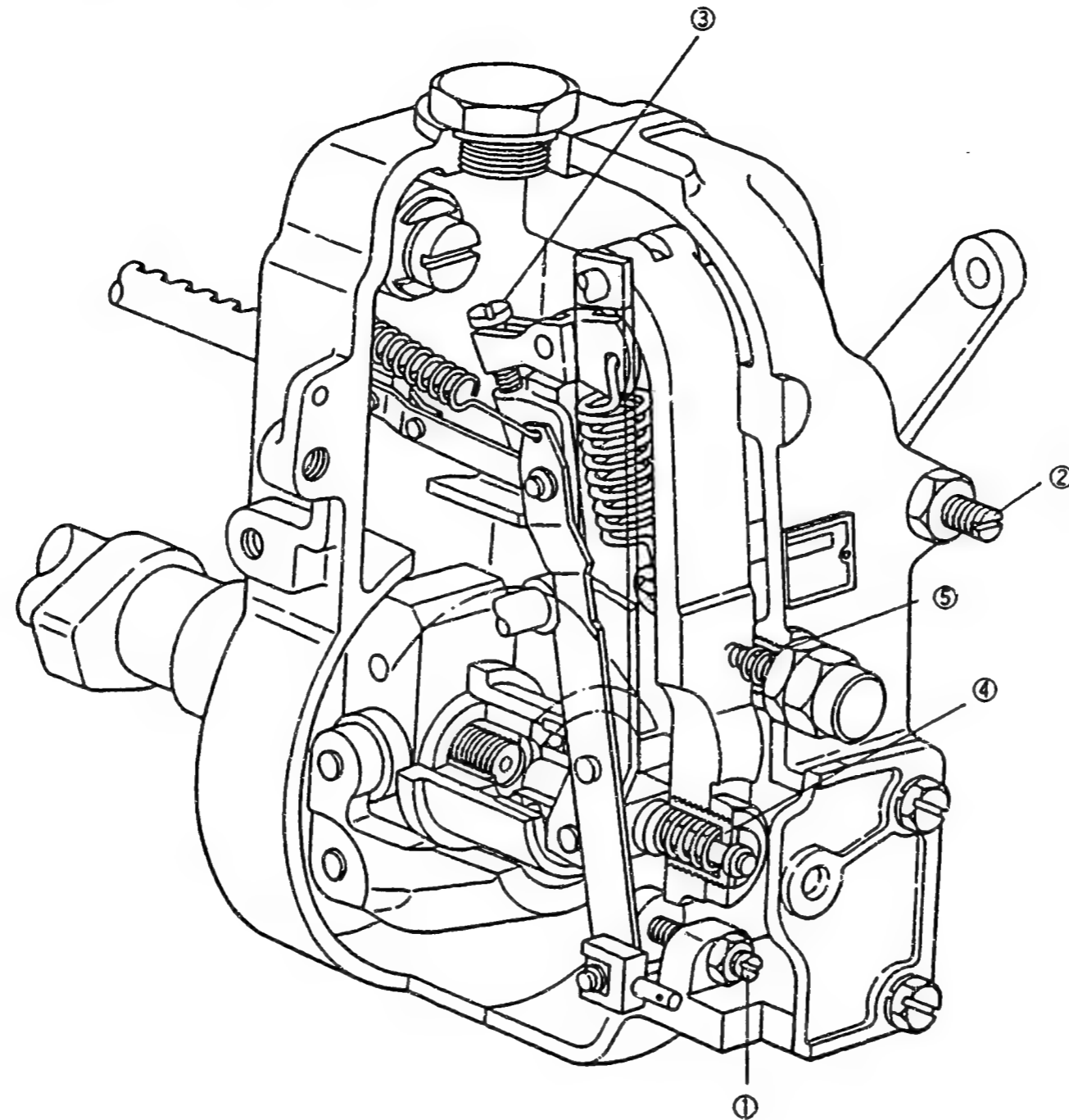

Figure 34

- 1 = Screw
- 2 = Screw
- 3 = Screw
- 4 = Spring capsule
- 5 = Spring capsule

101601-3540 4/4

G8

ZEXEL - Test values
Injection pumps



G9

ZEXEL - Test values
Injection pumps



ZEXEL - TEST VALUES
Injection pumps

BOSCH No.	:	9 400 610 202	1/4
ZEXEL No.	:	101602-3101	
Date	:	31.10.1992	[5]
Company	:	KOMATSU	
Engine	:	6D105 / 6136-71-1610	

IP-Type number : 101060-0870 / PE 6A
Governor type number : 105410-4580 / EP/RSV

TEST PREREQUISITES

Test oil : ISO-4113
Test oil inlet temperature °C : 40.00...45.00
Inlet pressure bar : 1.6
Test nozzle holder combination : 1 688 901 013
Opening pressure bar : 175
Test pressure line
Inner x Outer Dia - Length mm : 2.00 x 6.00 x 600

PORT CLOSING

Prestroke mm : 3.5 ± 0.05
Rod position mm : -
Port closing mark Cyl. No. : -
Cam sequence : 1-5-3-6-2-4

Port closing mark Cyl. No. : -
Port closing difference °NW : 0-60-120-180-240-300

Tolerance +- °C: 0.50 (0.75)

G10

ZEXEL - Test values
Injection pumps



Injection Quantity :

Adjusting Point	Rack Pos. (mm)	P. Speed (rpm)	Injection Q'ty (cm ³ /1000 str.)	Difference (%)	Fixed	Remarks
A	10.7	900	67.8 ± 1.0	± 2.0	Rack	Basic
B	10.7	750	58.4 ± 2.0	± 4.0	Rack	
H	approx. 8.4	350	12.2 ± 1.8	± 10.0	Rack	Basic
A	10.7	900	67.8 ± 1.0	-	Lever	

Timing Advance Specification :

Pump Speed (rpm)						
Advance Angle (deg)						



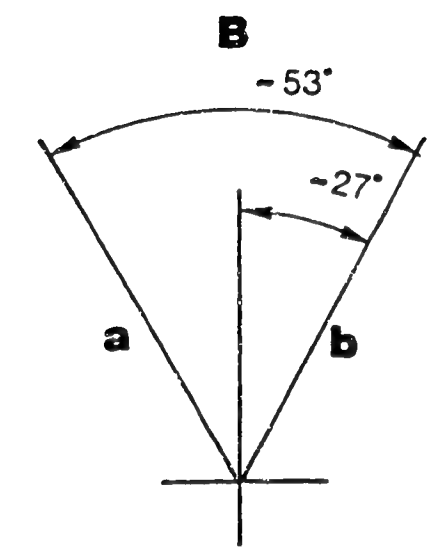
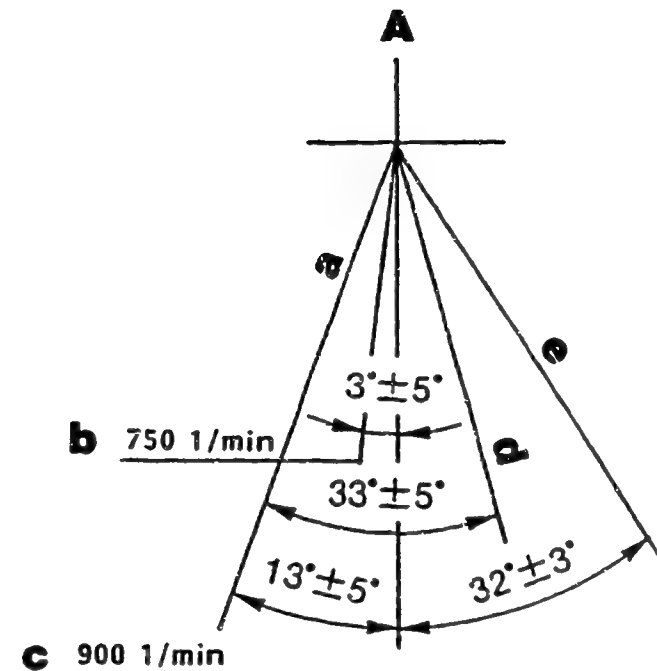
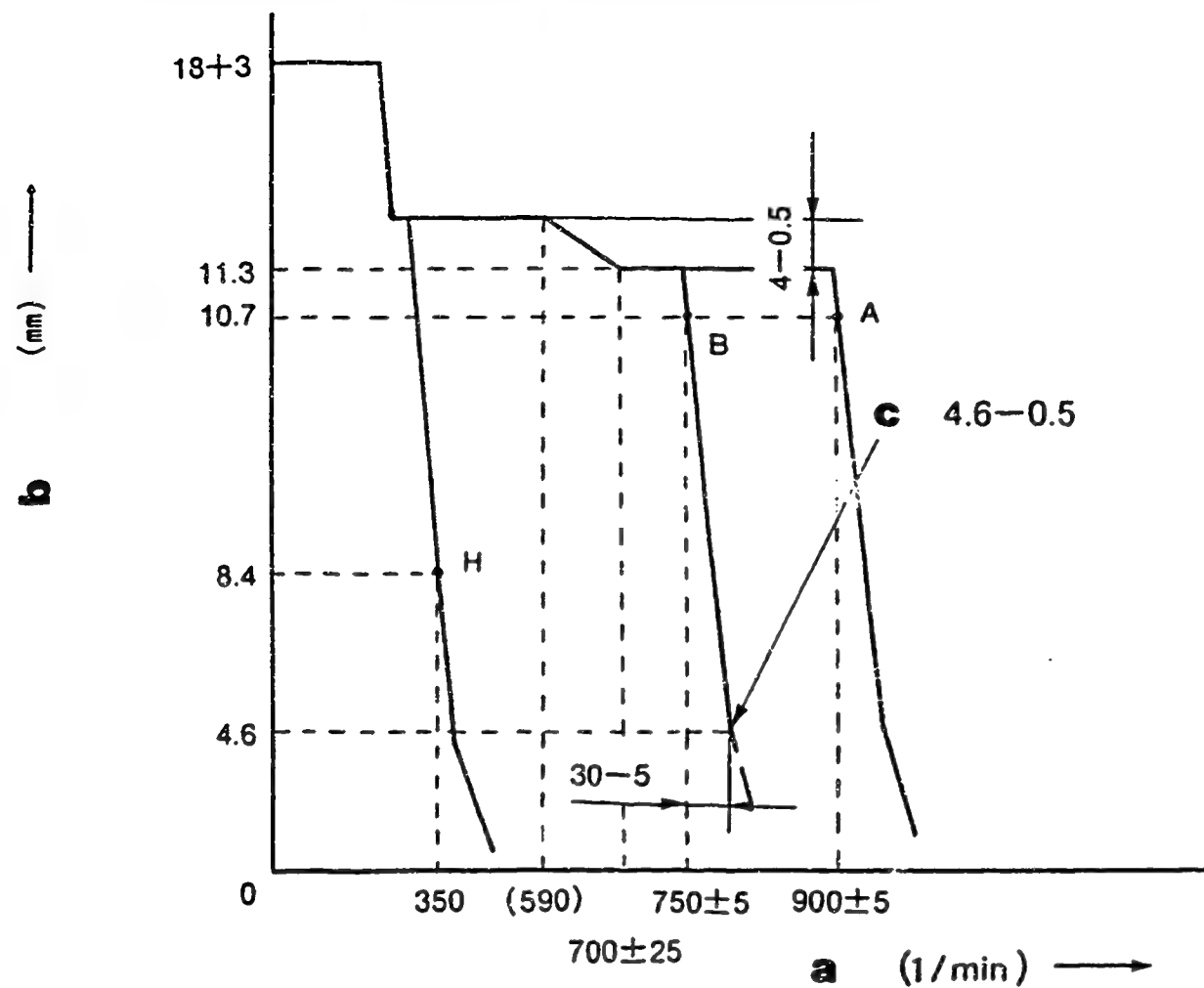

Figure 35

GOVERNOR ADJUSTMENT

101602-3101 2/4

Recommended speed droop adjustment screw position: 8

- a = Pump speed
- b = Control rack position
- c = Idle-sub spring setting:

A = Speed Control Lever Angle

B = Stop Lever Angle

- a = Full-speed
- b = Setting:
- c = Setting:
(on our shipment)
- d = Idling
- e = Stop

- a = Stop
- b = Normal

■ Note

- Before adjustment, remove the idling sub spring.
- Move the control lever fully in the stop direction, and set the minimum-speed stopper bolt so that the control rack position is 0.5 - 1.0 mm.

■ ADJUSTMENT

	Pump speed (rpm)	Rack position (mm)	Remarks
Full-load Adjustment (Temporary)	1100	10.7	<ul style="list-style-type: none"> • Adjust using screw (2) • Adjust using screw (1)
	600	11.3	
Torque Control spring Adjustment	(500)	14.8-15.3	<ul style="list-style-type: none"> • Adjust using spring capsule (4) • Confirm • Confirm the torque control stroke is: 4.0 -0.5 mm
	(590)	14.8-15.3	
	700 ± 25	11.3	
Idling Adjustment	0	18+3	<ul style="list-style-type: none"> • Fix the control lever • Adjust using spring capsule (5) • Confirm
	350	8.4	
Maximum-speed Adjustment	750 ± 5	10.7	<ul style="list-style-type: none"> • Fix the control lever • Confirm speed droop - adjust using screw (3) • Confirm
	750+25	4.6	
	+30 900 ± 5	10.7	
Full-load Adjustment	800	11.3	<ul style="list-style-type: none"> • Confirm
Control Lever Angle Measurement	<ul style="list-style-type: none"> • Measure the control lever angle at the "idling" and "full" positions. • When the control lever is depressed toward the "full" position, replace the shifter's shim with a thicker one. • When the control lever is depressed toward the "idling" position, replace the shifter's shim with a thinner one. 		
Rack Limiter Adjustment	-	-	<ul style="list-style-type: none"> • Adjust using screw

G15

ZEXEL - Test values

Injection pumps



G16

ZEXEL - Test values

Injection pumps



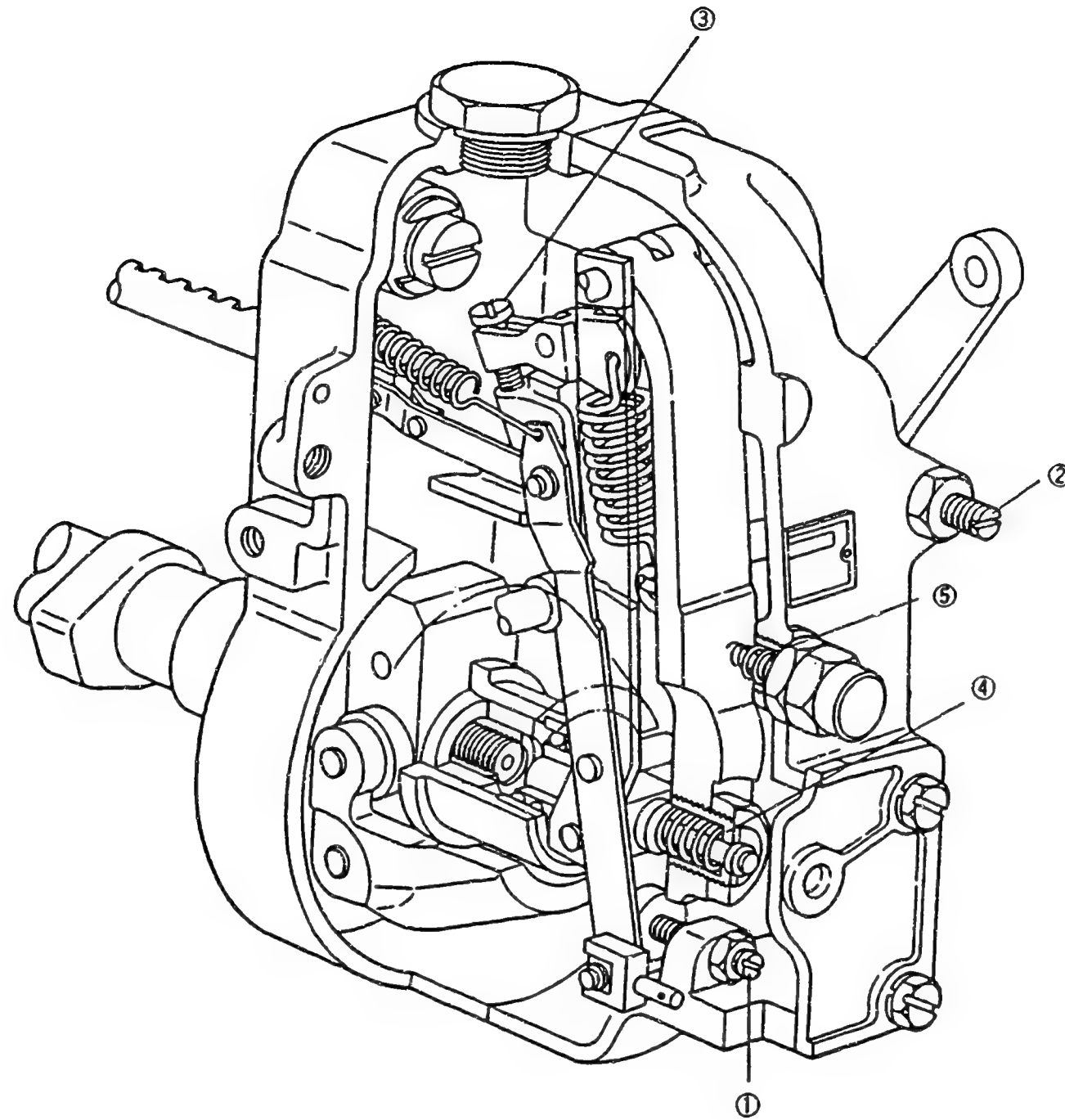

Figure 36

- 1 = Screw
- 2 = Screw
- 3 = Screw
- 4 = Spring capsule
- 5 = Spring capsule

101602-3101 4/4

G17

ZEXEL - Test values
Injection pumps



G18

ZEXEL - Test values
Injection pumps



ZEXEL - TEST VALUES
Injection pumps

BOSCH No.	:	9 400 610 203	1/4
ZEXEL No.	:	101602-3210	
Date	:	31.10.1992	[4]
Company	:	KOMATSU	
Engine	:	6D105 / 6136-71-1411	

IP-Type number : 101060-0810 / PE 6A
Governor type number : 105410-5580 / EP/RSV

TEST PREREQUISITES

Test oil : ISO-4113
Test oil inlet temperature °C : 40.00...45.00
Inlet pressure bar : 1.6
Test nozzle holder combination : 1 688 901 013
Opening pressure bar : 175
Test pressure line
Inner x Outer Dia - Length mm : 2.00 x 6.00 x 600

PORT CLOSING

Prestroke mm : 3.5 ± 0.05
Rod position mm : -
Port closing mark Cyl. No. : -
Cam sequence : 1-5-3-6-2-4

Port closing mark Cyl. No. : -
Port closing difference °NW : 0-60-120-180-240-300

Tolerance +- °C: 0.50 (0.75)



Injection Quantity :

Adjusting Point	Rack Pos. (mm)	P. Speed (rpm)	Injection Q'ty (cm ³ /1000 str.)	Difference (%)	Fixed	Remarks
A	8.0	1175	35.5 ± 1.0	± 2.0	Rack	Basic
H	approx. 8.5	350	11.0 ± 2.0	± 10.0	Rack	
A	8.0	1175	35.5 ± 1.0	-	Lever	Basic

Timing Advance Specification :

Pump Speed (rpm)						
Advance Angle (deg)						



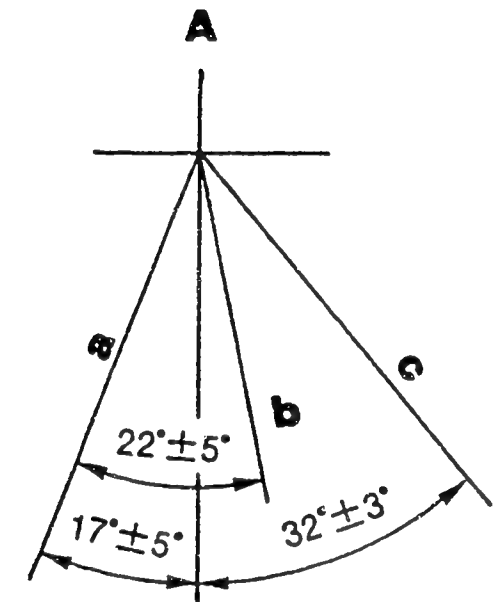
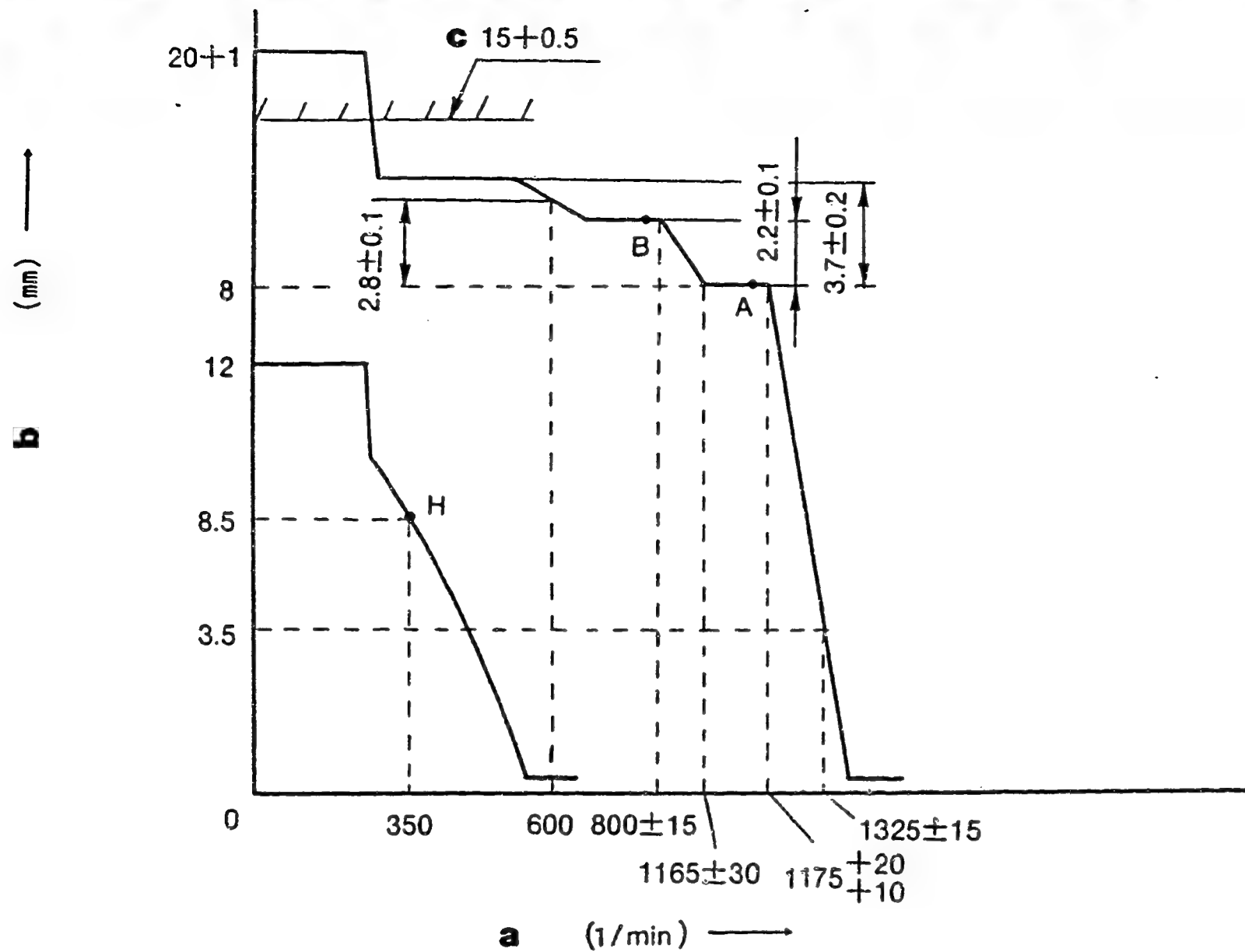

Figure 37

GOVERNOR ADJUSTMENT

Recommended speed droop adjustment screw position: 15

101602-3210 2/4

a = Pump speed
 b = Control rack position
 c = Control rack limit:

A = Speed Control Lever Angle

a = Full-speed
 b = Idling
 c = Stop

G 22

ZEXEL - Test values
 Injection pumps



G 23

ZEXEL - Test values
 Injection pumps



■ Note

- Before adjustment, remove the idling sub spring.
- Move the control lever fully in the stop direction, and set the minimum-speed stopper bolt so that the control rack position is 0.5 - 1.0 mm.

■ ADJUSTMENT

		Pump Speed (rpm)	Rack Position (mm)	Remarks
Full-load Adjustment (Temporary)		1375 600	8.0 8.0	<ul style="list-style-type: none"> • Adjust using screw (2) • Adjust using screw (1)
Torque Control Spring Adjustment	1st stroke	(350) 600	11.7 10.8	<ul style="list-style-type: none"> • Adjust using spring capsule (4)
	2st stroke	(700) 800 ± 15 1165 ± 30	10.2 10.8 ± 0.1 8.0	<ul style="list-style-type: none"> • Confirm
Idling Adjustment		0 350 -	12.0 8.5 -	<ul style="list-style-type: none"> • Fix the control lever • Adjust using spring capsule (5) • Confirm
Maximum Speed Adjustment		1175+20 +10 1325 ± 15 -	8.0 3.5 -	<ul style="list-style-type: none"> • Fix the control lever • Confirm speed droop - adjust using screw (3) • Confirm
Full-load Adjustment		1170	8.0	<ul style="list-style-type: none"> • Confirm
Control Lever Angle Measurement		<ul style="list-style-type: none"> • Measure the control lever angle at the "idling" and "full" positions. • When the control lever is depressed toward the "full" position, replace the shifter's shim with a thicker one. • When the control lever is depressed toward the "idling" position, replace the shifter's shim with a thinner one. 		
Rack Limiter Adjustment		-	-	<ul style="list-style-type: none"> • Adjust using screw

G 24

ZEXEL - Test values
Injection pumps



G 25

ZEXEL - Test values
Injection pumps



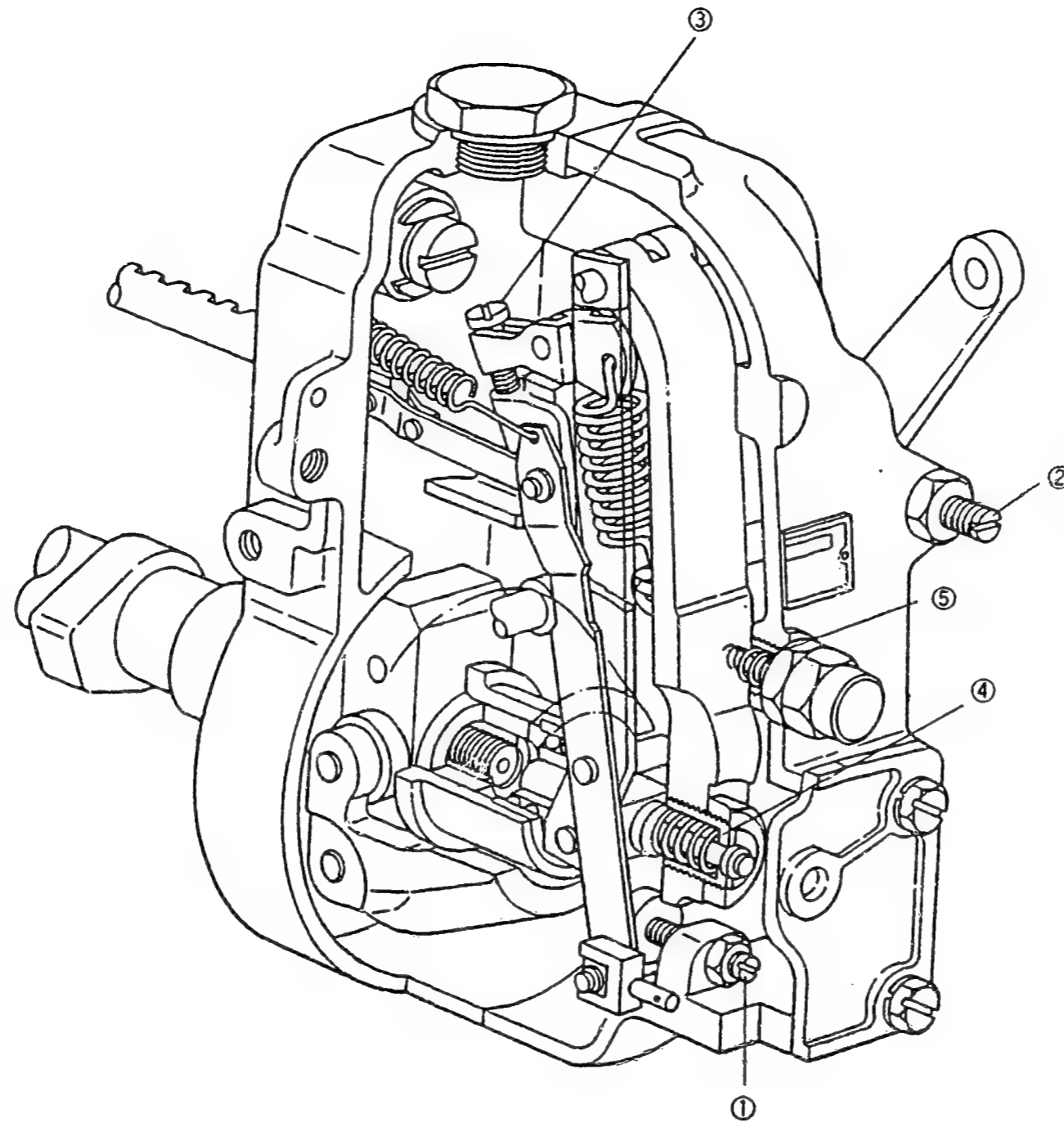

Figure 38

- 1 = Screw
- 2 = Screw
- 3 = Screw
- 4 = Spring capsule
- 5 = Spring capsule

101602-3210 4/4

G 26

ZEXEL - Test values
Injection pumps



G 27

ZEXEL - Test values
Injection pumps

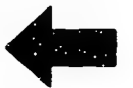

ZEXEL - TEST VALUES
Injection pumps

BOSCH No.	:	9 400 610 204	1/4
ZEXEL No.	:	101602-3232	
Date	:	31.10.1992	[2]
Company	:	KOMATSU	
Engine	:	SA6D110 / 6138-71-1400	

IP-Type number : 101060-2730 / PE6AD
Governor type number : 105410-5180 / EP/RSV

TEST PREREQUISITES

Test oil : ISO-4113
Test oil inlet temperature °C : 40.00...45.00
Inlet pressure bar : 1.6
Test nozzle holder combination : 1 688 901 013
Opening pressure bar : 175
Test pressure line
Inner x Outer Dia - Length mm : 2.00 x 6.00 x 600

PORT CLOSING

Prestroke mm : 4.0 ± 0.05
Rod position mm : -
Port closing mark Cyl. No. : -
Cam sequence : 1-5-3-6-2-4

Port closing mark Cyl. No. : -
Port closing difference °NW : 0-60-120-180-240-300

Tolerance +- °C: 0.50 (0.75)

H1

ZEXEL - Test values
Injection pumps



Injection Quantity :

Adjusting Point	Rack Pos. (mm)	P. Speed (rpm)	Injection Q'ty (cm ³ /1000 str.)	Difference (%)	Fixed	Remarks
A	10.2	900	102.7 ± 1.0	± 2.0	Rack	Basic
H	approx. 7.7	325	13.9 ± 1.2	± 10.0	Rack	
A	10.2	900	102.7 ± 1.0	-	Lever	Basic

Timing Advance Specification :

Pump Speed (rpm)						
Advance Angle (deg)						



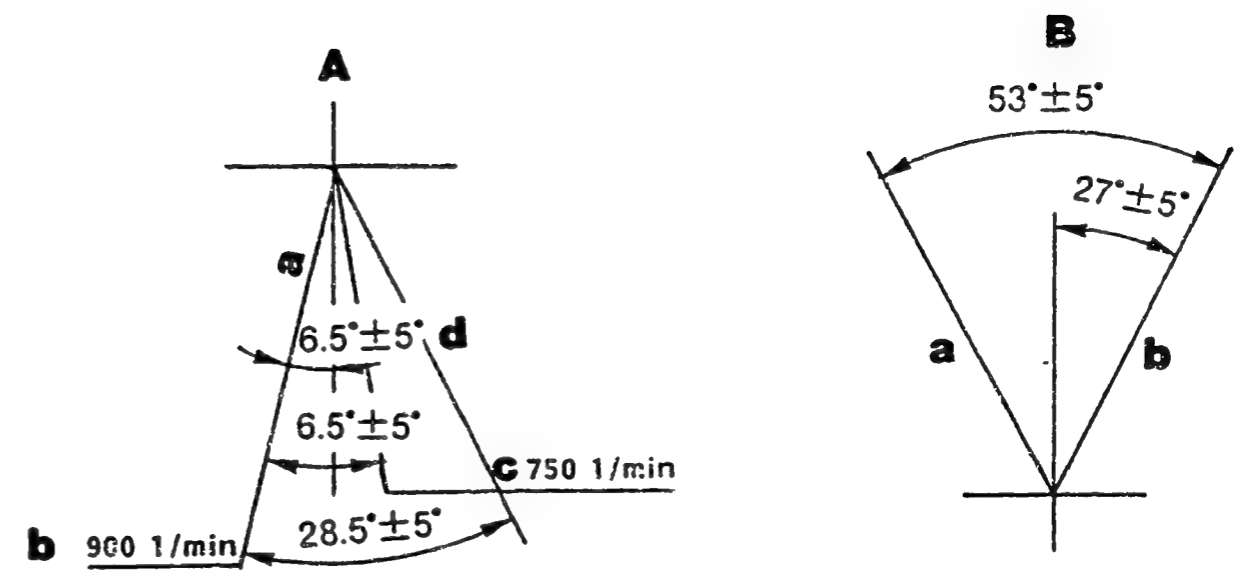
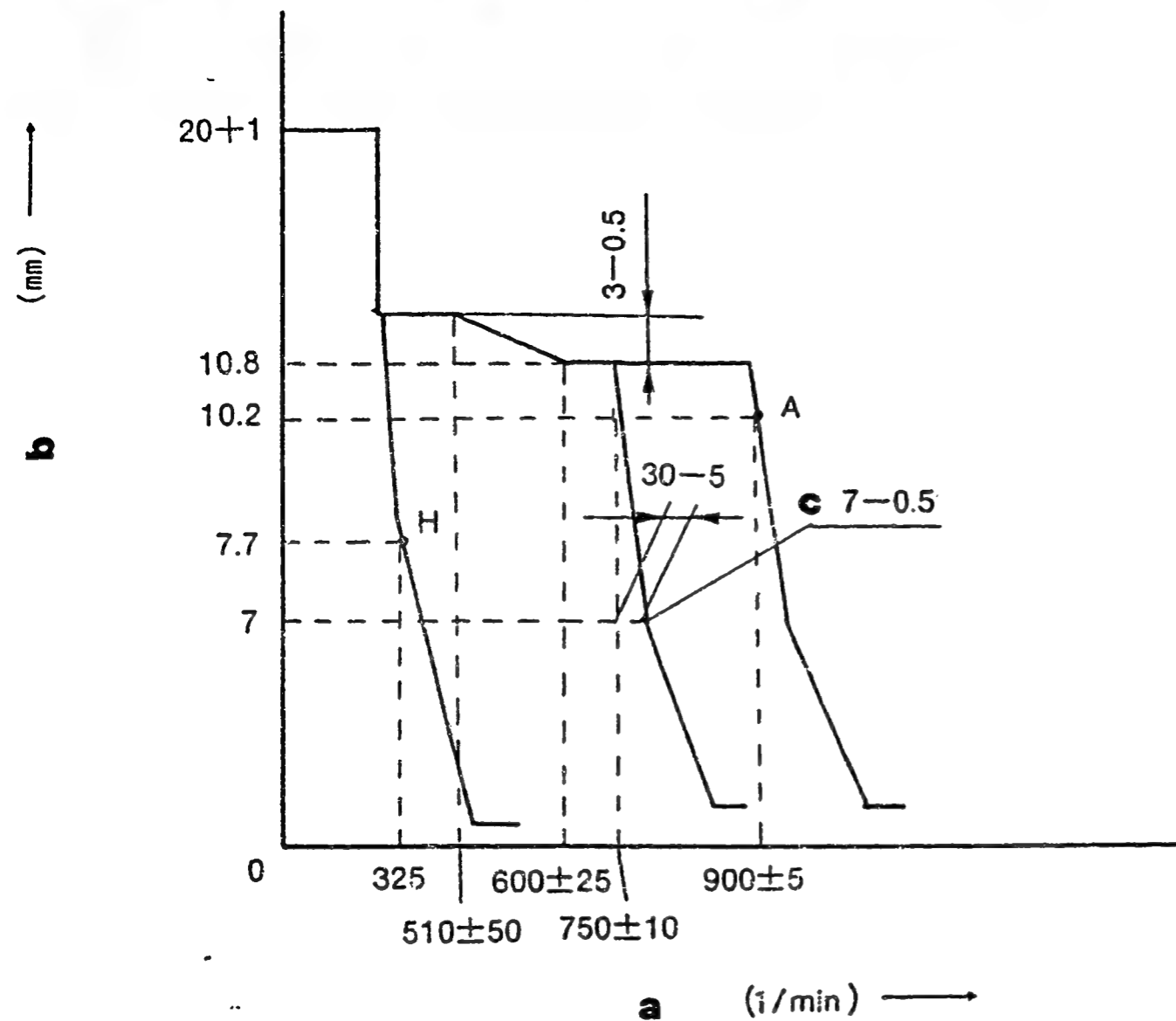

Figure 39

a = Pump speed
 b = Control rack position
 c = Control rack limit:

GOVERNOR ADJUSTMENT

101602-3232 2/4

Recommended speed droop adjustment screw position: 16

A = Speed Control Lever Angle

B = Stop Lever Angle

a = Full-speed
 b = Setting:
 (on our shipment)
 c = Setting:
 d = Idling

a = Stop
 b = Normal

H4

ZEXEL - Test values
 Injection pumps



H5

ZEXEL - Test values
 Injection pumps



■ Note

- Before adjustment, remove the idling sub spring.
- Move the control lever fully in the stop direction, and set the minimum-speed stopper bolt so that the control rack position is 0.5 - 1.0 mm.

■ ADJUSTMENT

	Pump speed (rpm)	Rack position (mm)	Remarks
Full-load Adjustment (Temporary)	1100 600	10.8 10.8	<ul style="list-style-type: none"> • Adjust using screw (2) • Adjust using screw (1)
Torque Control spring Adjustment	410 510 ± 50 600 ± 25	13.8 -0.5 13.8 -0.5 10.8	<ul style="list-style-type: none"> • Adjust using spring capsule (4) • Confirm • Confirm the torque control stroke is 3.0 -0.5 mm
Idling Adjustment	750+30 +25 325	7.0 7.7	<ul style="list-style-type: none"> • Fix the control lever • Adjust using spring capsule (5) • Adjust using control lever
Maximum-speed Adjustment	750 ± 10 750+30 +25 900 ± 5	10.8 7.0 10.2	<ul style="list-style-type: none"> • Fix the control lever • Confirm speed droop - adjust using screw (3) • Confirm
Full-load Adjustment	900	10.8	<ul style="list-style-type: none"> • Confirm
Control Lever Angle Measurement	<ul style="list-style-type: none"> • Measure the control lever angle at the "idling" and "full" positions. • When the control lever is depressed toward the "full" position, replace the shifter's shim with a thicker one. • When the control lever is depressed toward the "idling" position, replace the shifter's shim with a thinner one. 		
Rack Limiter Adjustment	-	-	<ul style="list-style-type: none"> • Adjust using screw

H6

ZEXEL - Test values
Injection pumps



H7

ZEXEL - Test values
Injection pumps



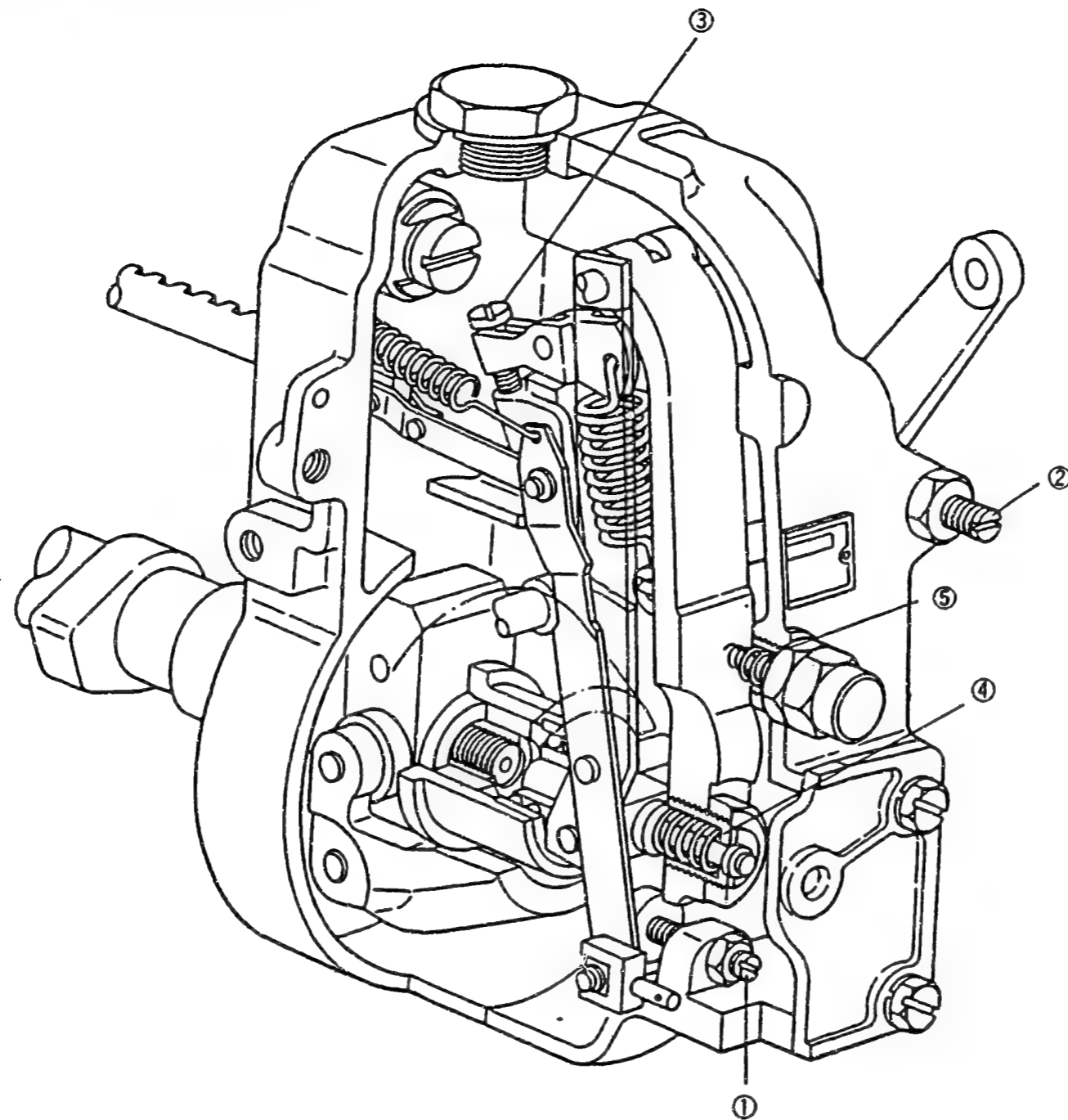

Figure 40

- 1 = Screw
- 2 = Screw
- 3 = Screw
- 4 = Spring capsule
- 5 = Spring capsule

101602-3232 4/4

H8

ZEXEL - Test values
Injection pumps



H9

ZEXEL - Test values
Injection pumps



ZEXEL - TEST VALUES
Injection pumps

BOSCH No.	:	9 400 610 205	1/4
ZEXEL No.	:	101602-3470	
Date	:	31.10.1992	[3]
Company	:	KOMATSU	
Engine	:	6D105 / 6136-72-1410	

IP-Type number : 101060-2470 / PE6A
Governor type number : 105410-6280 / EP/RSV

TEST PREREQUISITES

Test oil : ISO-4113
Test oil inlet temperature °C : 40.00...45.00
Inlet pressure bar : 1.6
Test nozzle holder combination : 1 688 901 013
Opening pressure bar : 175
Test pressure line
Inner x Outer Dia - Length mm : 2.00 x 6.00 x 600

PORT CLOSING

Prestroke mm : 3.3 ± 0.05
Rod position mm : -
Port closing mark Cyl. No. : -
Cam sequence : 1-5-3-6-2-4

port closing mark Cyl. No. : -
port closing difference °NW : 0-60-120-180-240-300

Tolerance +- °C: 0.50 (0.75)

H10

ZEXEL - Test values
Injection pumps



Injection Quantity :

Adjusting Point	Rack Pos. (mm)	P. Speed (rpm)	Injection Q'ty (cm ³ /1000 str.)	Difference (%)	Fixed	Remarks
A	7.5	1175	31.5 ± 1.0	± 2.0	Rack	Basic
H	approx. 8.0	350	9.5 ± 1.0	± 10.0	Rack	
A	7.5	1175	31.5 ± 1.0	-	Lever	Basic

Timing Advance Specification :

Pump Speed (rpm)						
Advance Angle (deg)						

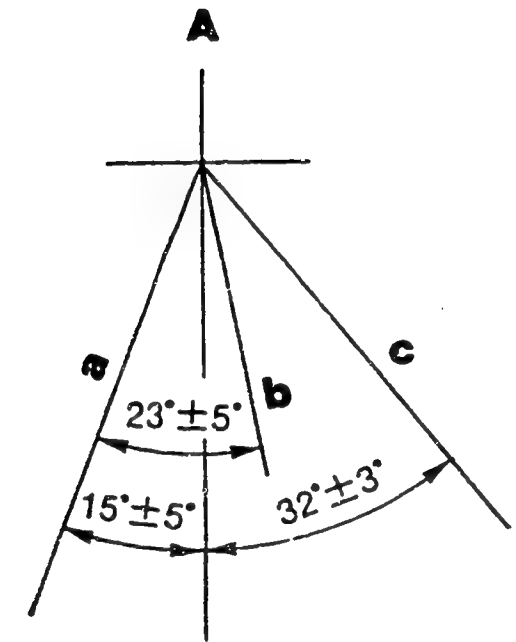
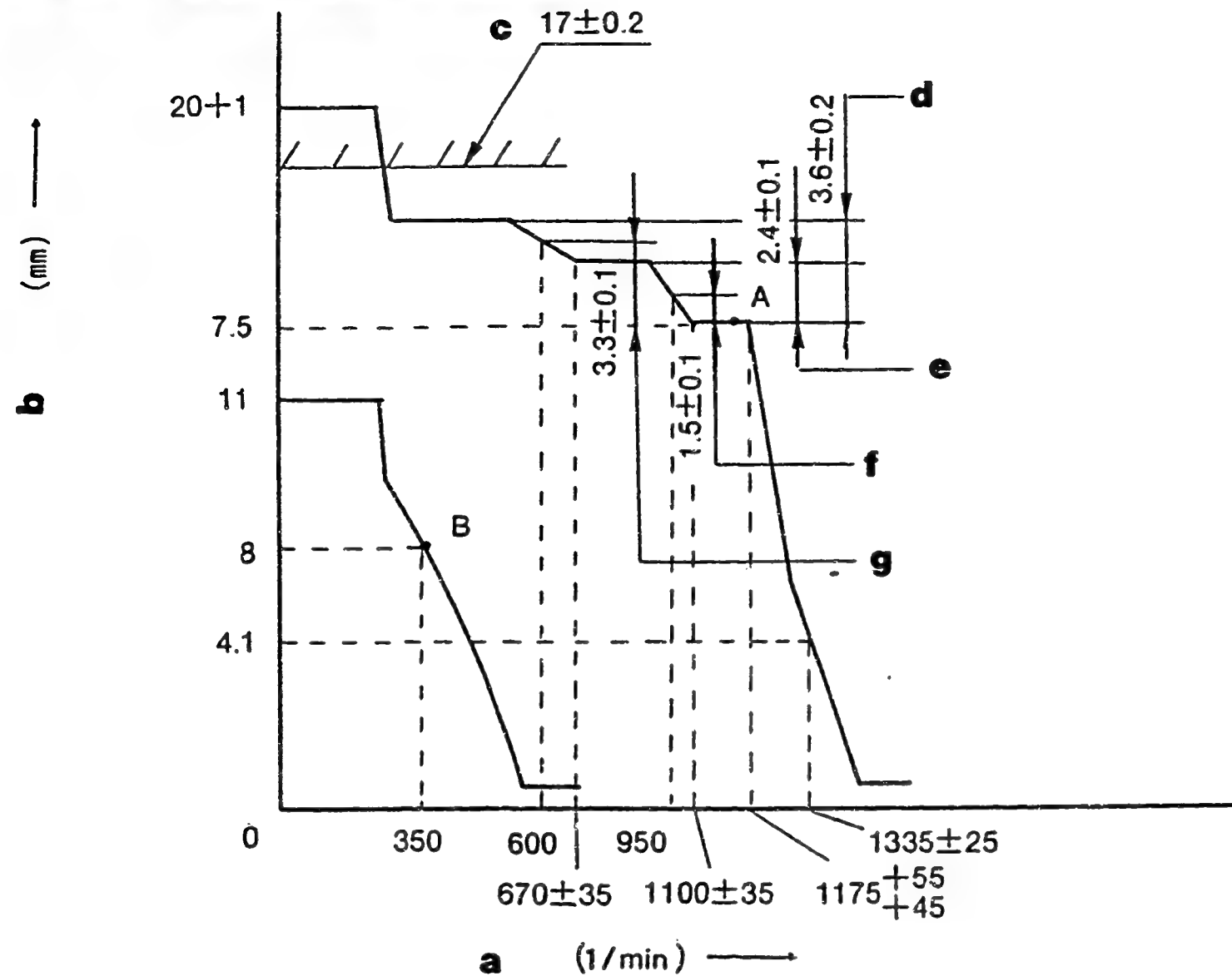

Figure 41

GOVERNOR ADJUSTMENT

- a = Pump speed
- b = Control rack position
- c = Control rack limit:
- d = Difference in control rack position between 1175 rpm and 550 rpm
- e = Difference in control rack position between 1175 rpm and 750 rpm
- f = Difference in control rack position between 1175 rpm and 950 rpm
- g = Difference in control rack position between 1175 rpm and 600 rpm

Recommended speed droop adjustment screw position: 15

A = Speed Control Lever Angle

- a = Full-speed
- b = Idling
- c = Stop

H13

ZEXEL - Test values
Injection pumps



H14

ZEXEL - Test values
Injection pumps



■ Note

- Before adjustment, remove the idling sub spring.
- Move the control lever fully in the stop direction, and set the minimum-speed stopper bolt so that the control rack position is 0.5 - 1.0 mm.

■ ADJUSTMENT

		Pump Speed (rpm)	Rack Position (mm)	Remarks
Full-load Adjustment (Temporary)		1375 600	7.5 7.5	<ul style="list-style-type: none"> • Adjust using screw (2) • Adjust using screw (1)
Torque Control Spring Adjustment	1st stroke	600 670 ± 35	10.8 9.9	<ul style="list-style-type: none"> • Adjust using spring capsule (4) • Confirm • Confirm the torque control stroke is 0.9 ± 0.1 mm
	2st stroke	950 1100 ± 35	9.0 7.5	<ul style="list-style-type: none"> • Adjust using spring capsule (4) • Confirm • Confirm the torque control stroke is 1.5 ± 0.1 mm
Idling Adjustment		0 350	11.0 8.0	<ul style="list-style-type: none"> • Fix the control lever • Adjust using spring capsule (5) • Confirm
Maximum Speed Adjustment		1175+55 +45 1335 ± 25	7.5 4.1	<ul style="list-style-type: none"> • Fix the control lever • Confirm speed droop - adjust using screw (3) • Confirm
Full-load Adjustment		1175	7.5	<ul style="list-style-type: none"> • Confirm
Control Lever Angle Measurement		<ul style="list-style-type: none"> • Measure the control lever angle at the "idling" and "full" positions. • When the control lever is depressed toward the "full" position, replace the shifter's shim with a thicker one. • When the control lever is depressed toward the "idling" position, replace the shifter's shim with a thinner one. 		
Rack Limiter Adjustment		0	17.0	<ul style="list-style-type: none"> • Adjust using screw

H15

ZEXEL - Test values
Injection pumps



H16

ZEXEL - Test values
Injection pumps



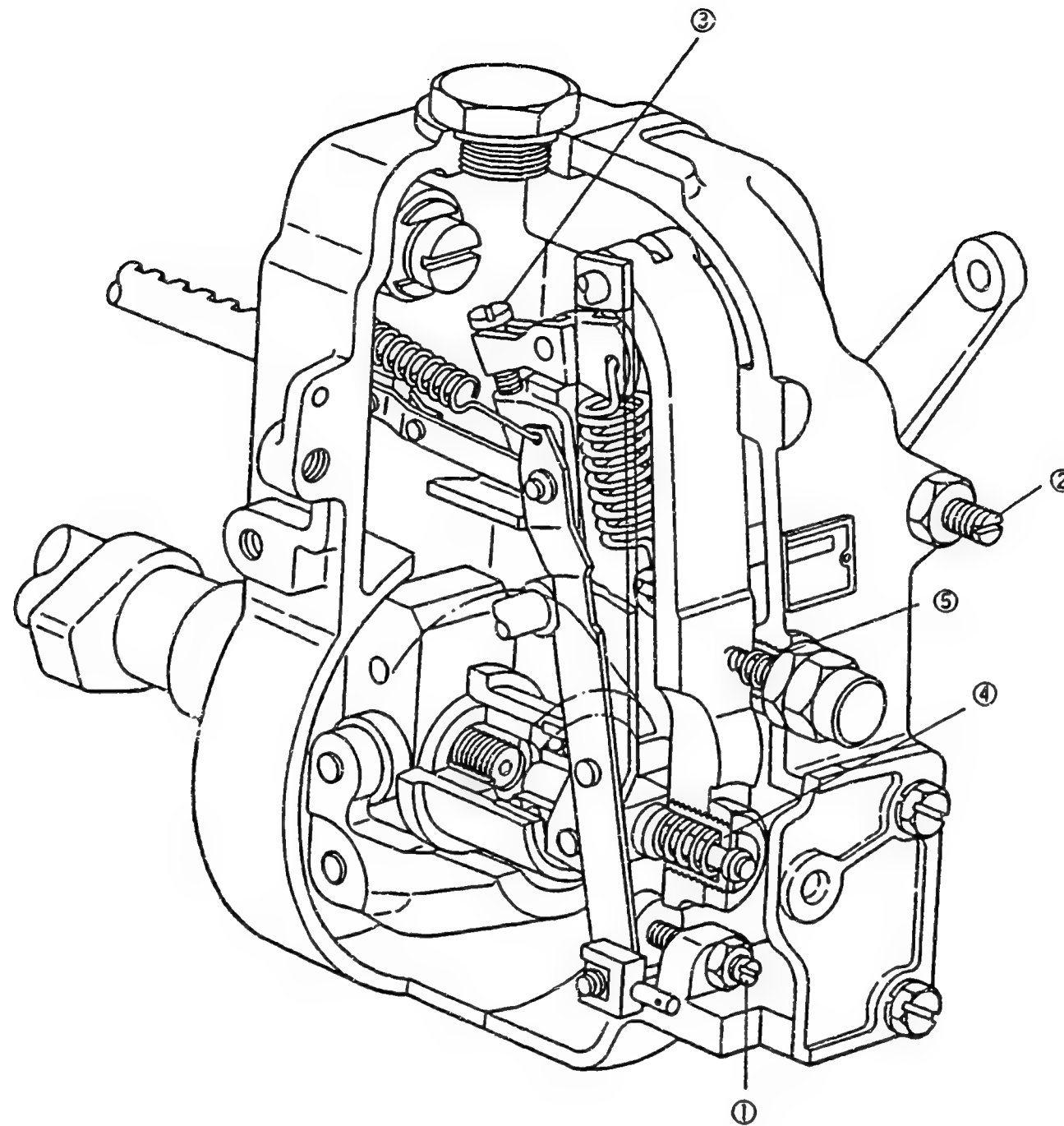

Figure 42

- 1 = Screw
- 2 = Screw
- 3 = Screw
- 4 = Spring capsule
- 5 = Spring capsule

ZEXEL - TEST VALUES
Injection pumps

BOSCH No.	:	9 400 610 206	1/4
ZEXEL No.	:	101602-3560	
Date	:	31.10.1992	[2]
Company	:	KOMATSU	
Engine	:	S6D105 / 6137-72-1310	

IP-Type number : 101060-2470 / PE6A
Governor type number : 105410-6400 / EP/RSV

TEST PREREQUISITES

Test oil : ISO-4113
Test oil inlet temperature °C : 40.00...45.00
Inlet pressure bar : 1.6
Test nozzle holder combination : 1 688 901 013
Opening pressure bar : 175
Test pressure line
Inner x Outer Dia - Length mm : 2.00 x 6.00 x 600

PORT CLOSING

Prestroke mm : 3.3 ± 0.05
Rod position mm : -
Port closing mark Cyl. No. : -
Cam sequence : 1-5-3-6-2-4

Port closing mark Cyl. No. : -
Port closing difference °NW : 0-60-120-180-240-300

Tolerance +- °C: 0.50 (0.75)

H19

ZEXEL - Test values
Injection pumps



Injection Quantity :

Adjusting Point	Rack Pos. (mm)	P. Speed (rpm)	Injection Q'ty (cm ³ /1000 str.)	Difference (%)	Fixed	Remarks
A	9.6	1075	64.0 ± 1.0	± 2.0	Rack	Basic
H	approx. 6.1	425	8.0 ± 1.0	± 10.0	Rack	
A	9.6	1075	64.0 ± 1.0	-	Lever	Basic

Timing Advance Specification :

Pump Speed (rpm)						
Advance Angle (deg)						



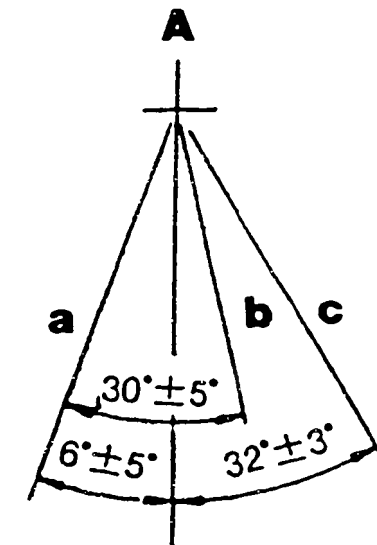
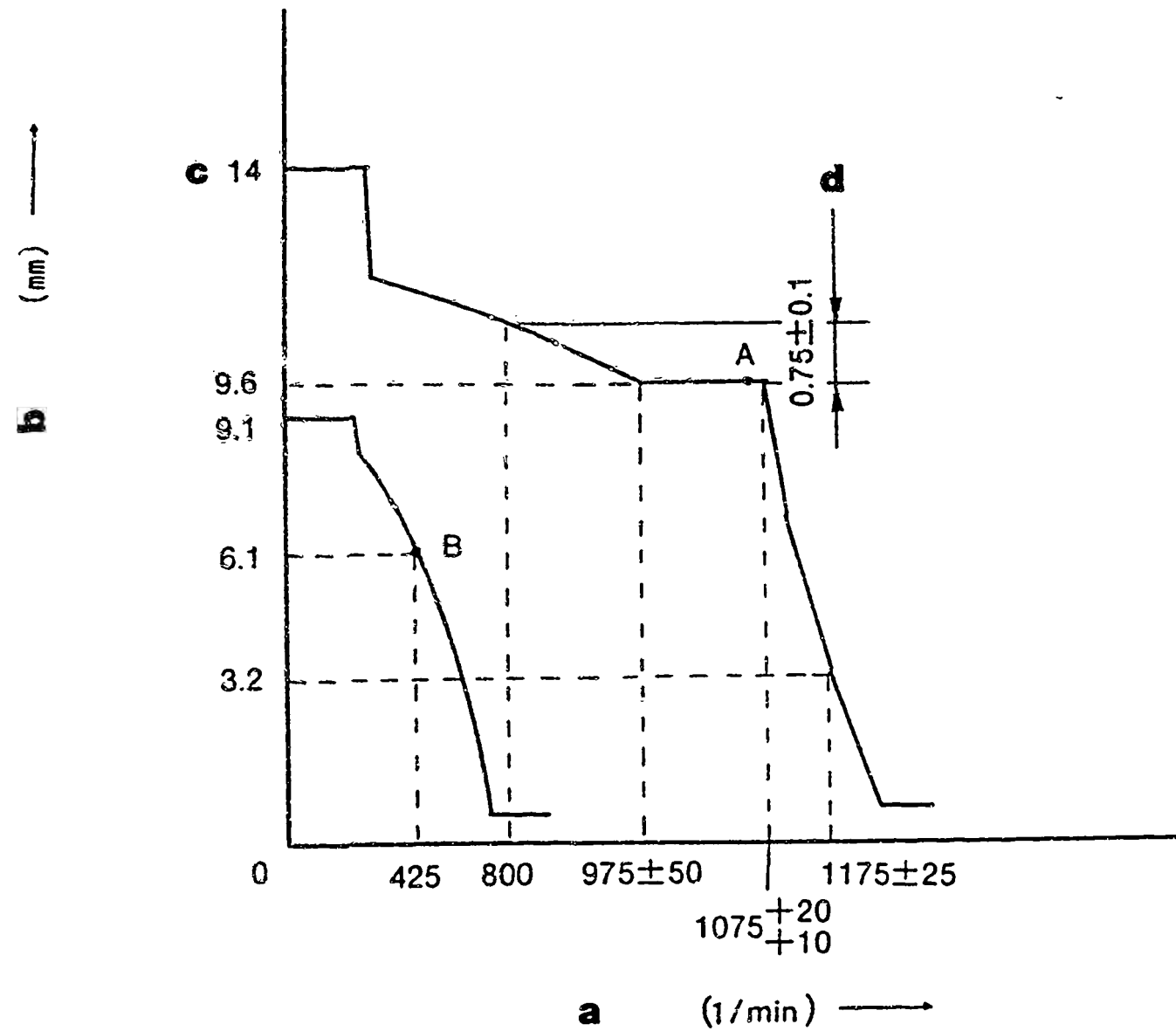

Figure 43

- a = Pump speed
- b = Control rack position
- c = Above
- d = Difference in control rack position between 1075 rpm and 800 rpm

GOVERNOR ADJUSTMENT

101602-3560 2/4

Recommended speed droop adjustment screw position: 5

Perform torque control spring adjustment when necessary

A = Speed Control Lever Angle

- a = Full-speed
- b = Idling
- c = Stop

H 22

ZEXEL - Test values
Injection pumps



H 23

ZEXEL - Test values
Injection pumps



■ Note

- Before adjustment, remove the idling sub spring.
- Move the control lever fully in the stop direction, and set the minimum-speed stopper bolt so that the control rack position is 0.5 - 1.0 mm.

■ ADJUSTMENT

	Pump speed (rpm)	Rack position (mm)	Remarks
Full-load Adjustment (Temporary)	1275 600	9.6 9.6	<ul style="list-style-type: none"> • Adjust using screw (2) • Adjust using screw (1)
Torque Control spring Adjustment	800 975 ± 50	10.35 9.6	<ul style="list-style-type: none"> • Adjust using spring capsule (4) • Confirm • Confirm the torque control stroke is 0.75 ± 0.1 mm
Idling Adjustment	0 425	9.1 6.1	<ul style="list-style-type: none"> • Fix the control lever • Adjust using spring capsule (5) • Confirm
Maximum-speed Adjustment	1175+20 +10 1175 ± 25	9.6 3.2	<ul style="list-style-type: none"> • Fix the control lever • Confirm speed droop - adjust using screw (3) • Confirm
Full-load Adjustment	1075	9.6	<ul style="list-style-type: none"> • Confirm
Control Lever Angle Measurement	<ul style="list-style-type: none"> • Measure the control lever angle at the "idling" and "full" positions. • When the control lever is depressed toward the "full" position, replace the shifter's shim with a thicker one. • When the control lever is depressed toward the "idling" position, replace the shifter's shim with a thinner one. 		
Rack Limiter Adjustment	-	-	<ul style="list-style-type: none"> • Adjust using screw

H24

ZEXEL - Test values
Injection pumps



H25

ZEXEL - Test values
Injection pumps



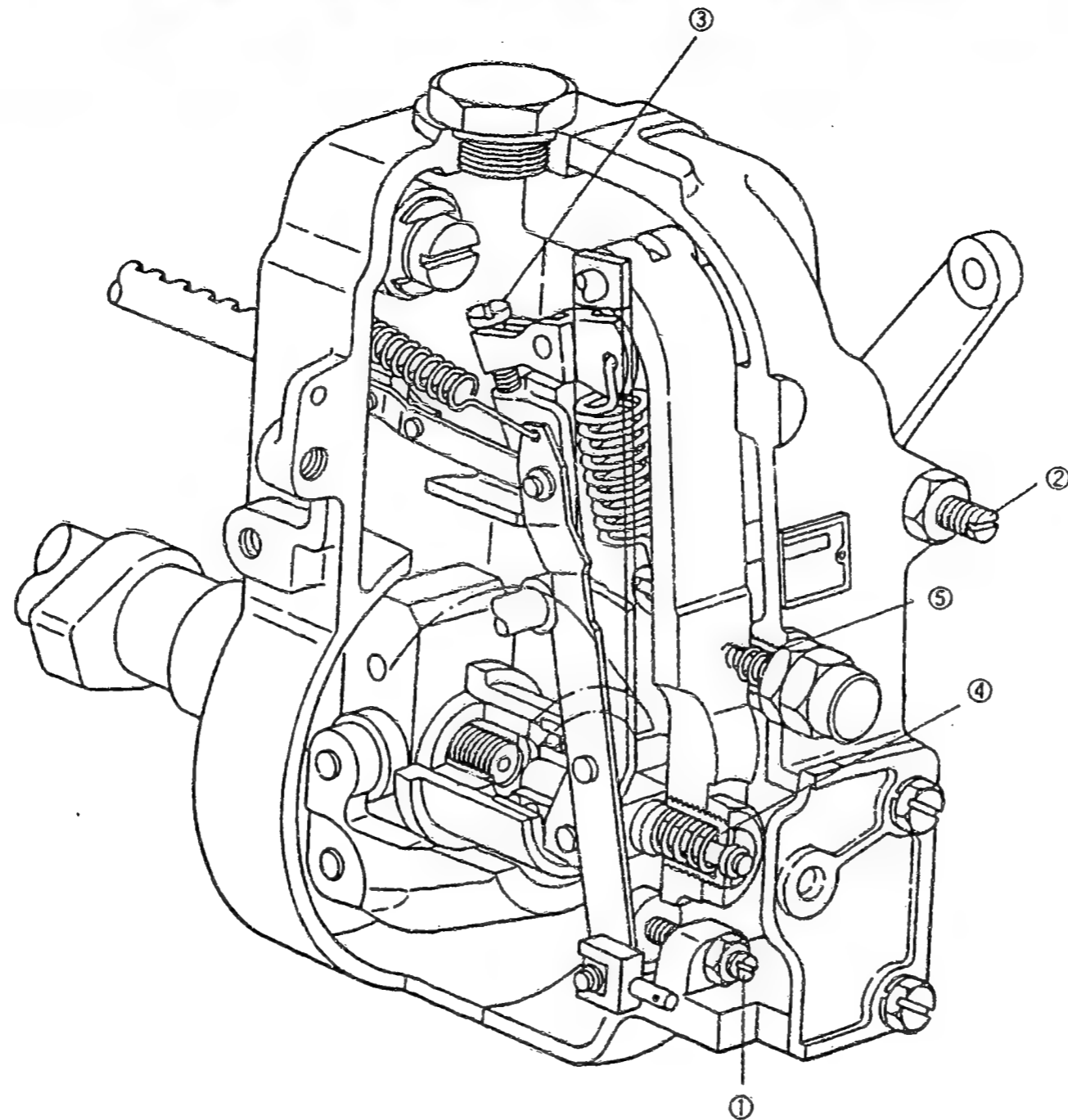

Figure 44

- 1 = Screw
- 2 = Screw
- 3 = Screw
- 4 = Spring capsule
- 5 = Spring capsule



ZEXEL - TEST VALUES
Injection pumps

BOSCH No.	:	9 400 610 207	1/4
ZEXEL No.	:	101602-3591	
Date	:	31.10.1992	[2]
Company	:	KOMATSU	
Engine	:	S6D105 / 6137-72-1610	

IP-Type number : 101060-2530 / PE 6A
Governor type number : 105410-6431 / EP/RSV

TEST PREREQUISITES

Test oil : ISO-4113
Test oil inlet temperature °C : 40.00...45.00
Inlet pressure bar : 1.6
Test nozzle holder combination : 1 688 901 013
Opening pressure bar : 175
Test pressure line
Inner x Outer Dia - Length mm : 2.00 x 6.00 x 600

PORT CLOSING

Prestroke mm : 3.3 ± 0.05 °
Rod position mm : -
Port closing mark Cyl. No. : -
Cam sequence : 1-5-3-6-2-4

Port closing mark Cyl. No. : -
Port closing difference °NW : 0-60-120-180-240-300

Tolerance +- °C: 0.50 (0.75)

J1

ZEXEL - Test values
Injection pumps



Injection Quantity :

Adjusting Point	Rack Pos. (mm)	P Speed (rpm)	Injection Q'ty (cm ³ /1000 str.)	Difference (%)	Fixed	Remarks
A	11.5	750	104.0 ± 1.0	± 2.0	Rack	Basic
H	approx. 8.0	350	10.0 ± 1.5	± 10.0	Rack	
A	11.5	750	104.0 ± 1.0	-	Lever	Basic

Timing Advance Specification :

Pump Speed (rpm)					
Advance Angle (deg)					

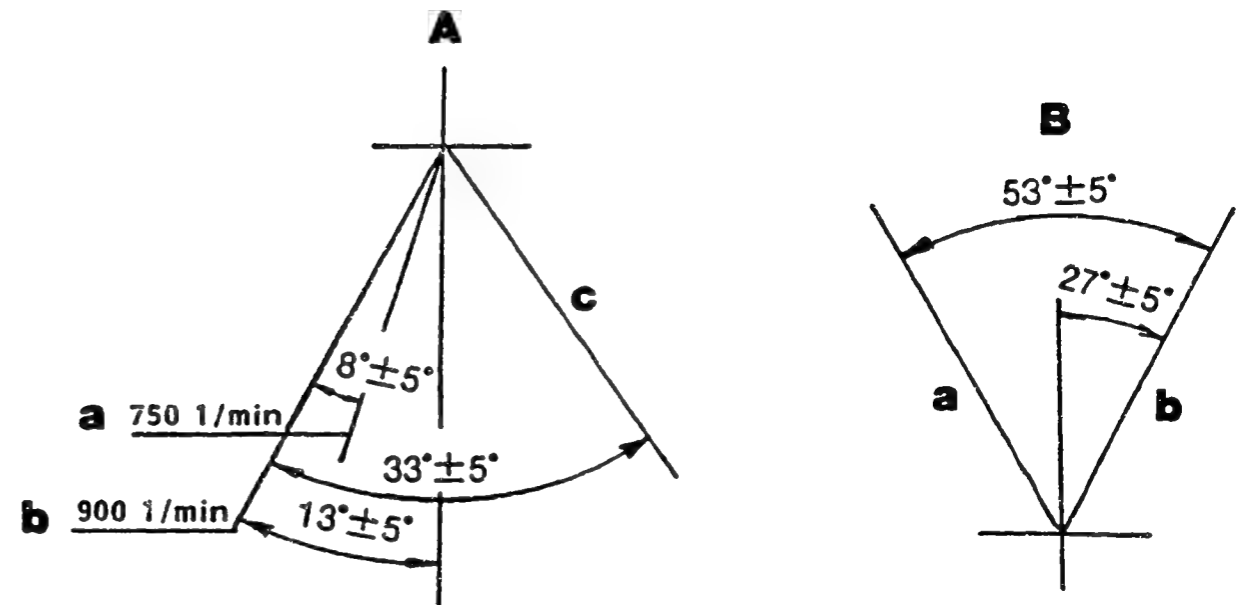
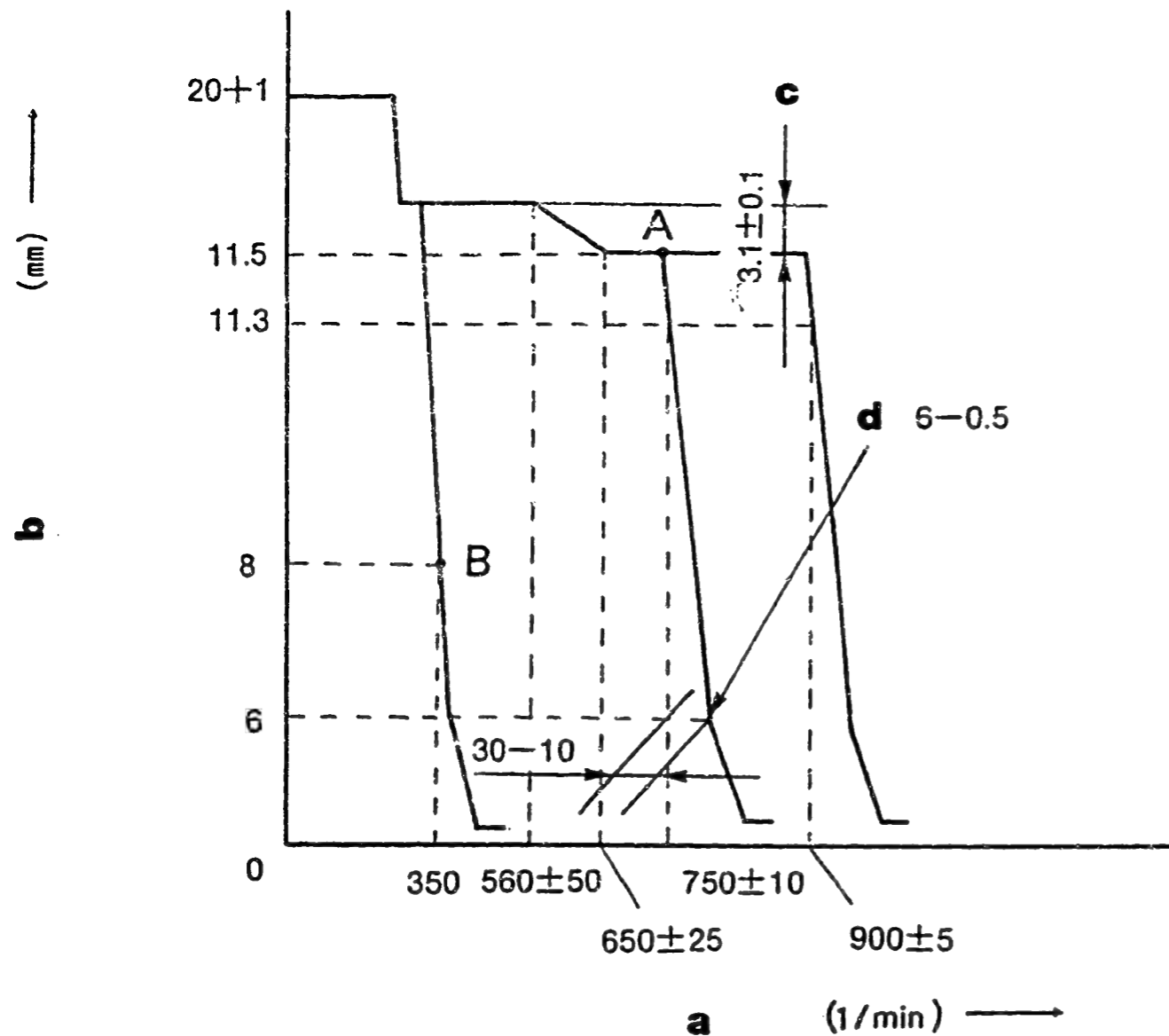

Figure 45

- a = Pump speed
- b = Control rack position
- c = Difference in control rack position between 800 rpm and 500 rpm
- d = Idle-sub spring setting:

GOVERNOR ADJUSTMENT

Recommended speed droop adjustment screw position: 15

101602-3591 2/4

A = Speed Control Lever Angle

C = Stop Lever Angle

- a = Setting:
- b = Setting: (On our shipment)
- c = Idling

- a = Stop
- b = Normal

J4

ZEXEL - Test values.
Injection pumps



J5

ZEXEL - Test values
Injection pumps



■ Note

- Before adjustment, remove the idling sub spring.
- Move the control lever fully in the stop direction, and set the minimum-speed stopper bolt so that the control rack position is 0.5 - 1.0 mm.

■ ADJUSTMENT

		Pump Speed (rpm)	Rack Position (mm)	Boost pressure kPa (mmHg)	Remarks
Full-load Adjustment (Temporary)		1100 600	11.3 11.5	-	<ul style="list-style-type: none"> • Adjust using screw (2) • Adjust using screw (1)
Torque Control Spring Adjust- ment	1.st stroke	approx. 460 560 ± 50 650 ± 25	14.6 14.6 11.5	-	<ul style="list-style-type: none"> • Adjust using spring capsule (4) • Confirm • Confirm the torque control stroke is: 3.1 ± 0.1 mm
	2.st stroke	-	-	-	<ul style="list-style-type: none"> • Adjust using spring capsule (4) • Confirm • Confirm the torque control stroke is: (mm)
Maximum-speed Adjustment		750 ± 10 750+30 +20	11.3 6.0	-	<ul style="list-style-type: none"> • Fix the control lever • Confirm speed droop - adjust using screw (3) • Confirm
Boost Compensator System		-	-	-	<ul style="list-style-type: none"> • Fix the control lever • Adjust using screw (6) • Confirm the boost compensator stroke is: (mm)
Idling Adjustment		750+30 +20	6.0	-	<ul style="list-style-type: none"> • Fix the control lever • Adjust using spring capsule (5) • Confirm
1. Idling Sub.Spring					
2. Control Lever	H	350	8.0	-	<ul style="list-style-type: none"> • Adjust using the control lever
Full-load Adjustment		750	11.5	-	<ul style="list-style-type: none"> • Confirm
Control Lever Angle Measurement		<ul style="list-style-type: none"> • Measure the control lever angle at the "idling" and "full" positions. • When the control lever is depressed toward the "full" position, replace the shifter's shim with a thicker one. • When the control lever is depressed toward the "idling" position, replace the shifter's shim with a thinner one. 			
Control Rack Limiter Adjustment		-	-	-	<ul style="list-style-type: none"> • Adjust using screw

J6

ZEXEL - Test values
Injection pumps



J7

ZEXEL - Test values
Injection pumps



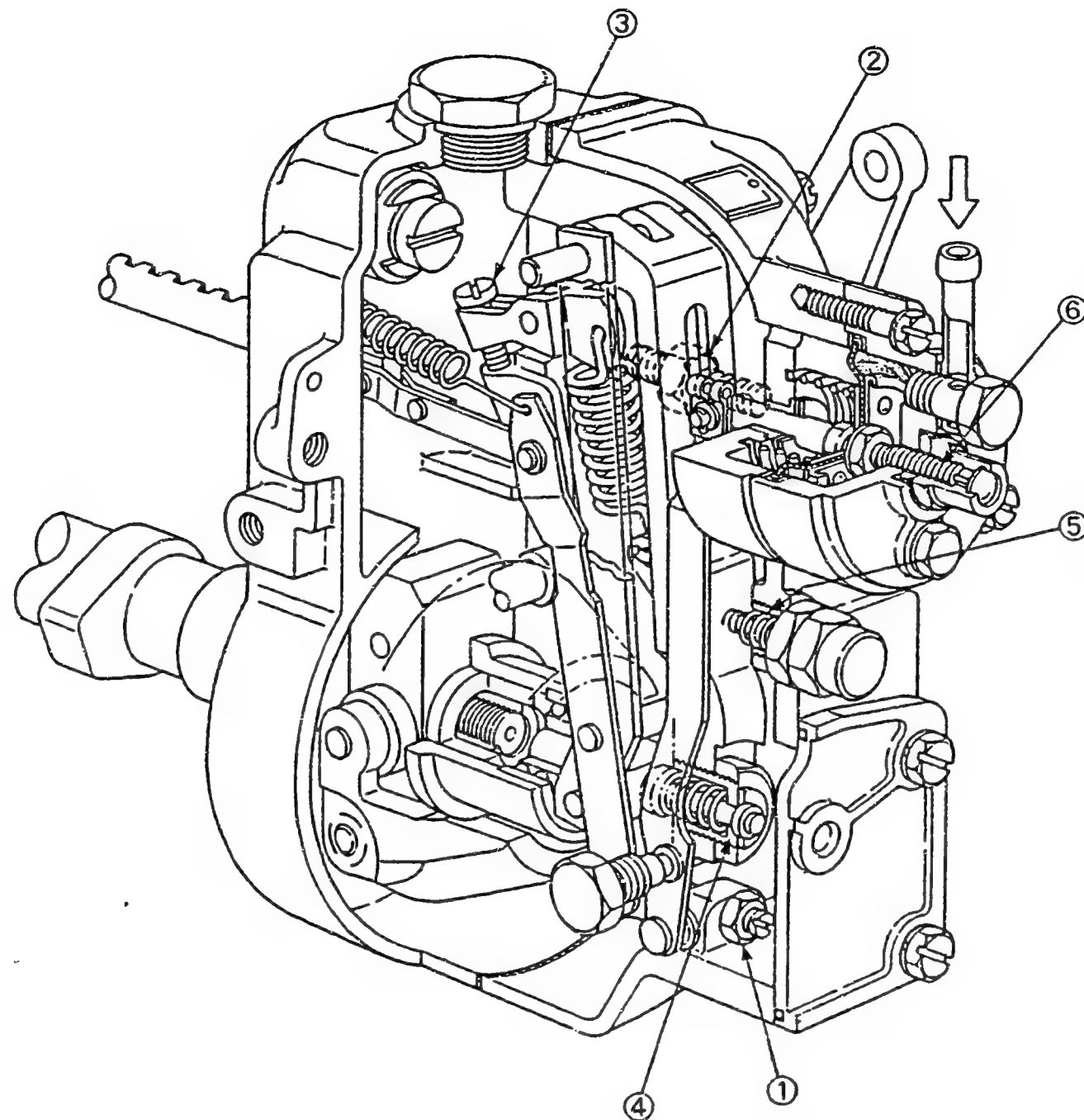

Figure 46

- 1 = Screw
- 2 = Screw
- 3 = Screw
- 4 = Spring capsule
- 5 = Spring capsule
- 6 = Screw

J8

ZEXEL - Test values
Injection pumps



J9

ZEXEL - Test values
Injection pumps



ZEXEL - TEST VALUES
Injection pumps

BOSCH No.	:	9 400 610 208	1/4
ZEXEL No.	:	101602-3860	
Date	:	31.10.1992	[1]
Company	:	KOMATSU	
Engine	:	6D105 / 6136-72-1321	

IP-Type number : 101060-2470 / PE6A
Governor type number : 105410-7220 / EP/RSV

TEST PREREQUISITES

Test oil : ISO-4113
Test oil inlet temperature °C : 40.00...45.00
Inlet pressure bar : 1.6
Test nozzle holder combination : 1 688 901 013
Opening pressure bar : 175
Test pressure line
Inner x Outer Dia - Length mm : 2.00 x 6.00 x 600

PORT CLOSING

Prestroke mm : 3.3 ± 0.05
Rod position mm : -
Port closing mark Cyl. No. : -
Cam sequence : 1-5-3-6-2-4

Port closing mark Cyl. No. : -
Port closing difference °NW : 0-60-120-180-240-300

Tolerance +- °C: 0.50 (0.75)

J10

ZEXEL - Test values

Injection pumps



Injection Quantity :

Adjusting Point	Rack Pos. (mm)	P. Speed (rpm)	Injection Q'ty (cm ³ /1000 str.)	Difference (%)	Fixed	Remarks
A	10.4	950	50.5 ± 1.0	± 2.0	Rack	Basic
H	approx. 8.7	400	9.2 ± 1.0	± 10.0	Rack	
A	10.4	950	50.5 ± 1.0	-	Lever	Basic

Timing Advance Specification :

Pump Speed (rpm)						
Advance Angle (deg)						

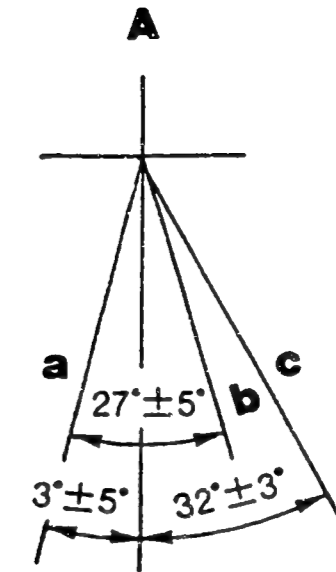
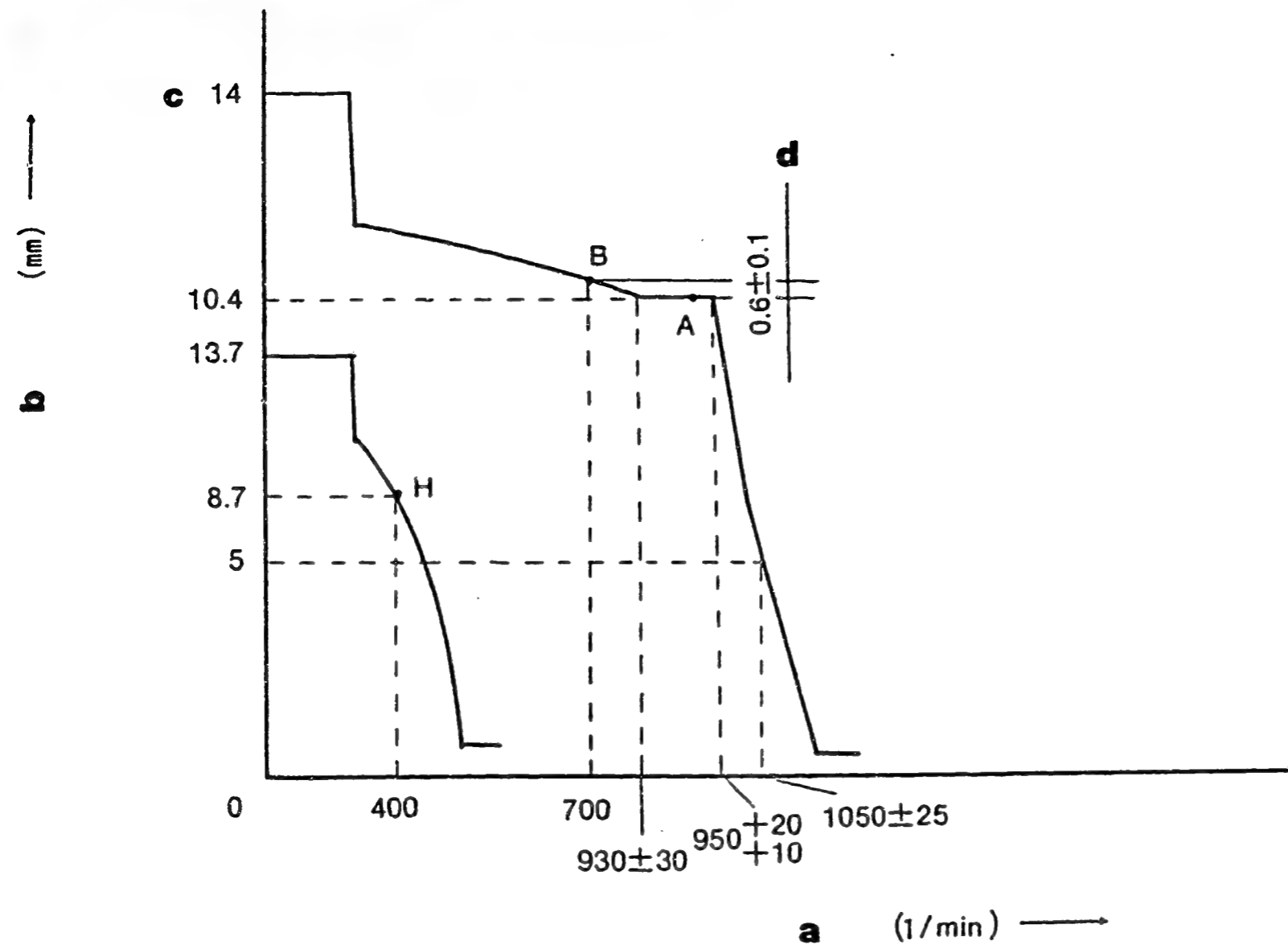

Figure 47

GOVERNOR ADJUSTMENT

101602-3860 2/4

Recommended speed droop adjustment screw position: 13

- a = Pump speed
- b = Control rack position
- c = Above
- d = Difference in control rack position between 950 rpm and 700 rpm

A = Speed Control Lever Angle

- a = Full-speed
- b = Idling
- c = Stop

J13

ZEXEL - Test values
Injection pumps



J14

ZEXEL - Test values
Injection pumps



■ Note

- Before adjustment, remove the idling sub spring.
- Move the control lever fully in the stop direction, and set the minimum-speed stopper bolt so that the control rack position is 0.5 - 1.0 mm.

■ ADJUSTMENT

	Pump speed (rpm)	Rack position (mm)	Remarks
Full-load Adjustment (Temporary)	1150 600	10.4 10.4	<ul style="list-style-type: none"> • Adjust using screw (2) • Adjust using screw (1)
Torque Control spring Adjustment	700 930 ± 30	11.0 10.4	<ul style="list-style-type: none"> • Adjust using spring capsule (4) • Confirm • Confirm the torque control stroke is 0.6 ± 0.1 mm
Idling Adjustment	0 400	13.7 8.7	<ul style="list-style-type: none"> • Fix the control lever • Adjust using spring capsule (5) • Confirm
Maximum-speed Adjustment	950+20 +10 1050 ± 25	10.4 5.0	<ul style="list-style-type: none"> • Fix the control lever • Confirm speed droop - adjust using screw (3) • Confirm
Full-load Adjustment	1100	10.4	<ul style="list-style-type: none"> • Confirm
Control Lever Angle Measurement	<ul style="list-style-type: none"> • Measure the control lever angle at the "idling" and "full" positions. • When the control lever is depressed toward the "full" position, replace the shifter's shim with a thicker one. • When the control lever is depressed toward the "idling" position, replace the shifter's shim with a thinner one. 		
Rack Limiter Adjustment	-	-	<ul style="list-style-type: none"> • Adjust using screw

J15

ZEXEL - Test values
Injection pumps



J16

ZEXEL - Test values
Injection pumps



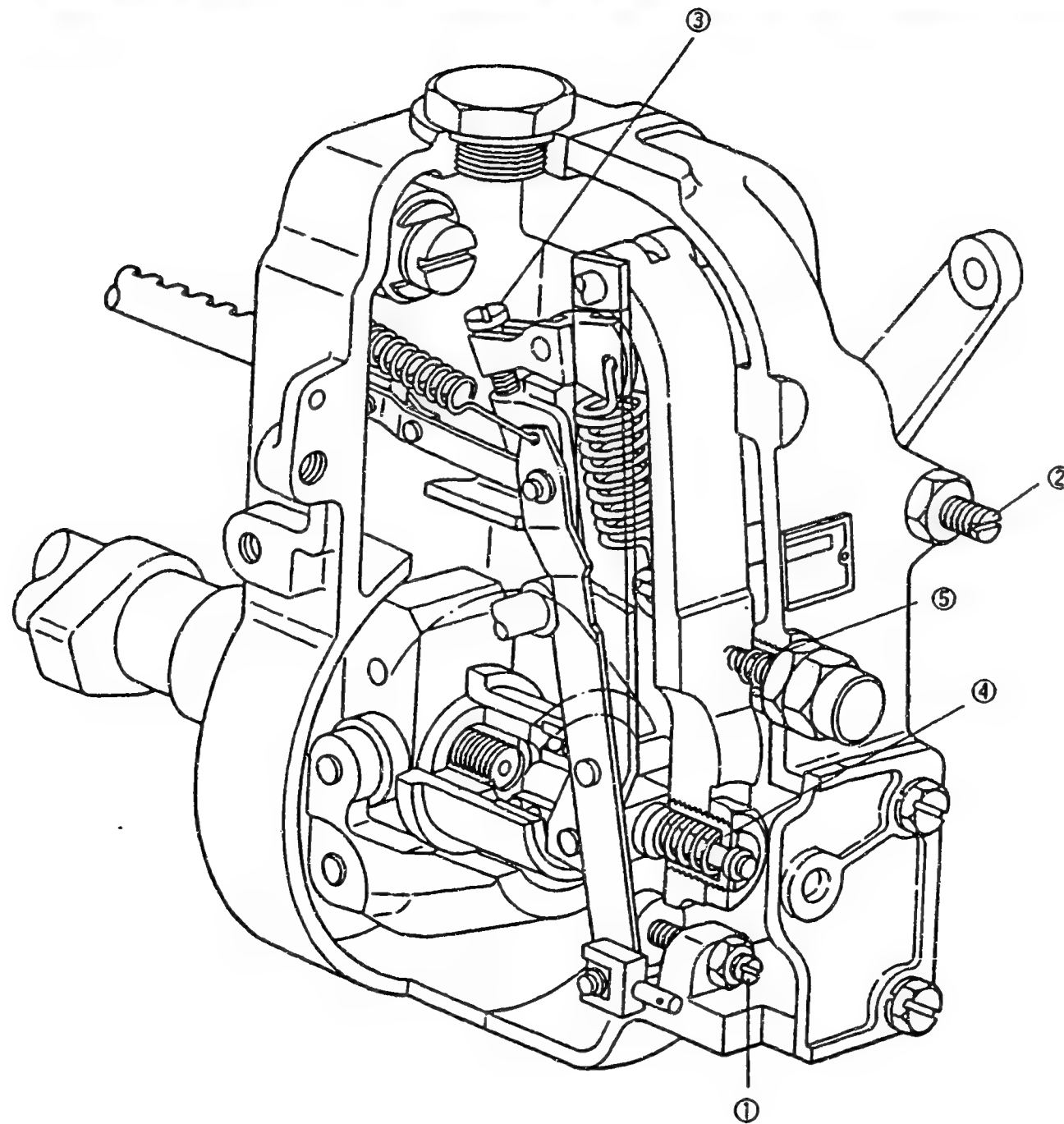

Figure 48

- 1 = Screw
- 2 = Screw
- 3 = Screw
- 4 = Spring capsule
- 5 = Spring capsule

101602-3860 4/4

J17

ZEXEL - Test values
Injection pumps



J18

ZEXEL - Test values
Injection pumps



ZEXEL - TEST VALUES
Injection pumps

BOSCH No.	:	9 400 610 209	1/4
ZEXEL No.	:	101602-3982	
Date	:	31.10.1992	[5]
Company	:	KOMATSU	
Engine	:	S6D105 / 6137-72-1321	
IP-Type number	:	101060-2470 / PE6A	
Governor type number	:	105410-7630 / EP/RSV	

TEST PREREQUISITES

Test oil	:	ISO-4113
Test oil inlet temperature °C	:	40.00...45.00
Inlet pressure bar	:	1.6
Test nozzle holder combination	:	1 688 901 013
Opening pressure bar	:	175
Test pressure line	:	
Inner x Outer Dia - Length mm	:	2.00 x 6.00 x 600

PORT CLOSING

Prestroke mm	:	3.3 ± 0.05
Rod position mm	:	-
Port closing mark Cyl. No.	:	-
Cam sequence	:	1-5-3-6-2-4
Port closing mark Cyl. No.	:	-
Port closing difference °NW	:	0-60-120-180-240-300
Tolerance +- °C	:	0.50 (0.75)

J19

ZEXEL - Test values
Injection pumps



Injection Quantity :

Adjusting Point	Rack Pos. (mm)	P. Speed (rpm)	Injection Q'ty (cm ³ /1000 str.)	Difference (%)	Fixed	Remarks
A	10.3	1050	54.5 ± 1.0	± 2.0	Rack	Basic
H	approx. 7.0	425	7.0 ± 1.0	± 10.0	Rack	
A	10.3	1050	54.5 ± 1.0	-	Lever	Basic

Timing Advance Specification :

Pump Speed (rpm)						
Advance Angle (deg)						



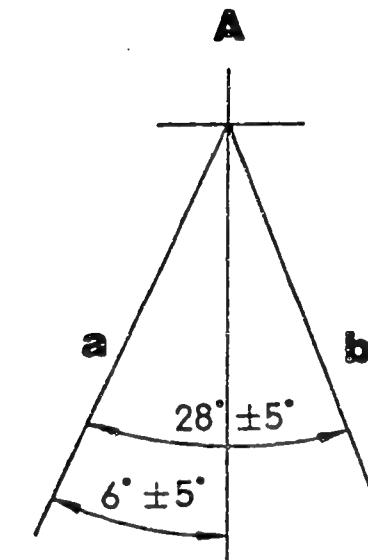
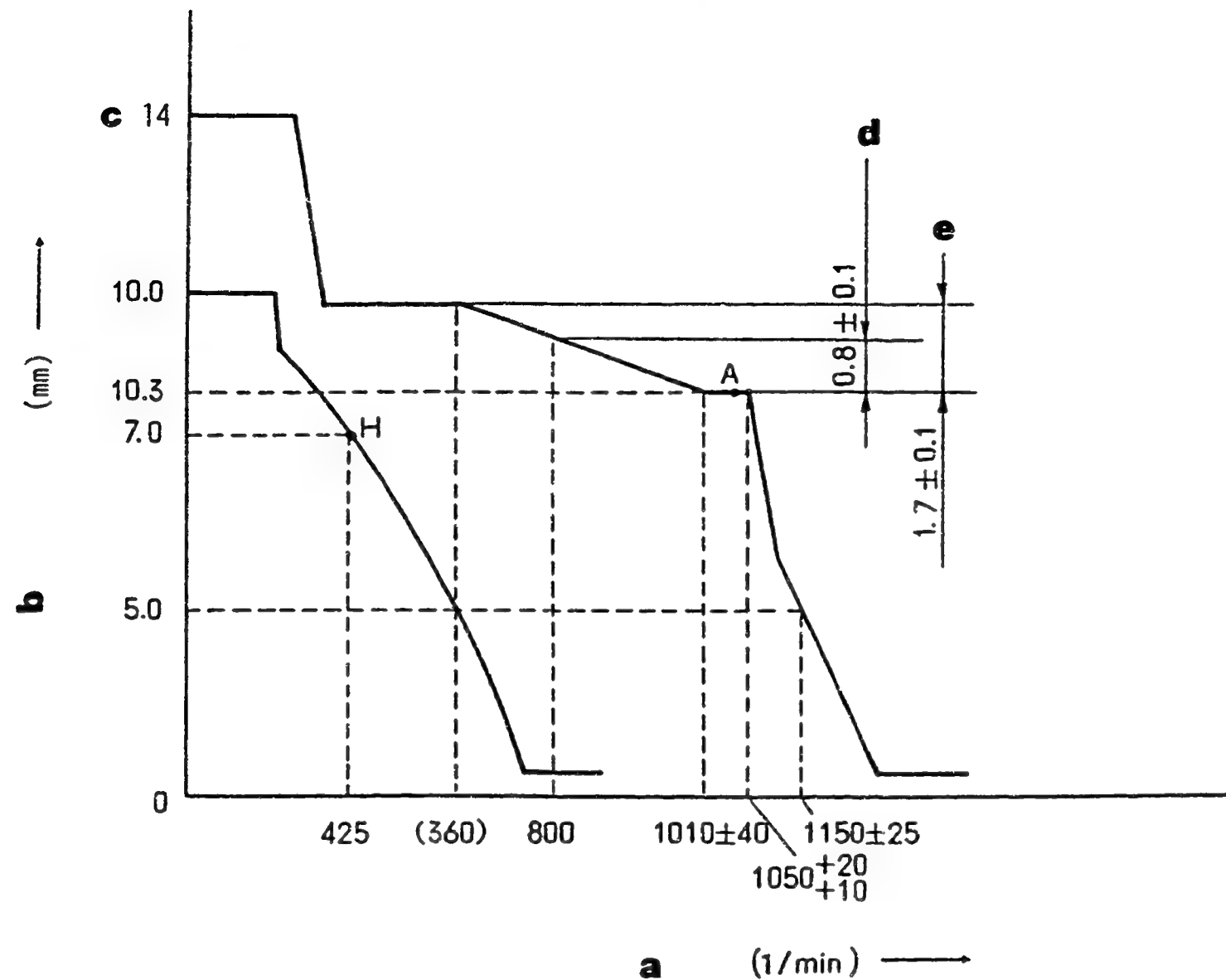

Figure 49

GOVERNOR ADJUSTMENT

101602-3982 2/4

Recommended speed droop adjustment screw position: 7

- a = Pump speed
- b = Control rack position
- c = Above
- d = Difference in control rack position between 1050 rpm and 800 rpm
- e = Difference in control rack position between 1050 rpm and 300 rpm

A = Speed Control Lever Angle

- a = Full-speed
- b = Idling

J22

ZEXEL - Test values
Injection pumps



J23

ZEXEL - Test values
Injection pumps



■ Note

- Before adjustment, remove the idling sub spring.
- Move the control lever fully in the stop direction, and set the minimum-speed stopper bolt so that the control rack position is 0.5 - 1.0 mm.

■ ADJUSTMENT

	Pump speed (rpm)	Rack position (mm)	Remarks
Full-load Adjustment (Temporary)	1250	10.3	<ul style="list-style-type: none"> • Adjust using screw (2) • Adjust using screw (1)
	600	10.3	
Torque Control spring Adjustment	260	12.0	<ul style="list-style-type: none"> • Adjust using spring capsule (4) • Confirm • Confirm the torque control stroke is 1.7 ± 0.1 mm
	approx. 360	12.0	
	800	11.1	
	1010 ± 40	10.3	
Idling Adjustment	0	10.0	<ul style="list-style-type: none"> • Fix the control lever • Adjust using spring capsule (5) • Confirm
	425	7.0	
Maximum-speed Adjustment	$1050+20$	10.3	<ul style="list-style-type: none"> • Fix the control lever • Confirm speed droop - adjust using screw (3) • Confirm
	$+10$ 1150 ± 25	5.0	
Full-load Adjustment	1050	10.3	<ul style="list-style-type: none"> • Confirm
Control Lever Angle Measurement	<ul style="list-style-type: none"> • Measure the control lever angle at the "idling" and "full" positions. • When the control lever is depressed toward the "full" position, replace the shifter's shim with a thicker one. • When the control lever is depressed toward the "idling" position, replace the shifter's shim with a thinner one. 		
Rack Limiter Adjustment	-	-	<ul style="list-style-type: none"> • Adjust using screw

J24

ZEXEL - Test values

Injection pumps



J25

ZEXEL - Test values

Injection pumps



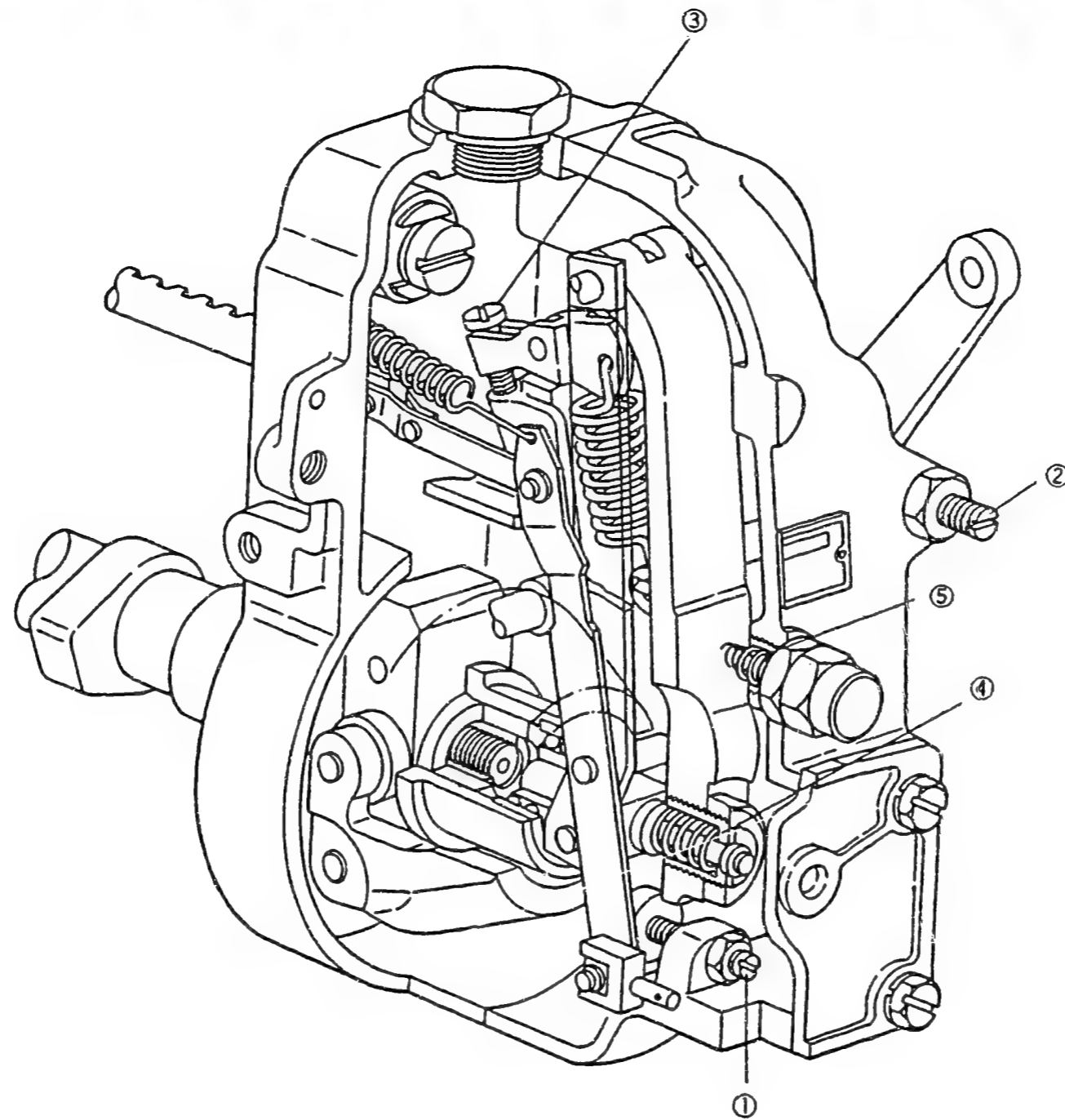

Figure 50

- 1 = Screw
- 2 = Screw
- 3 = Screw
- 4 = Spring capsule
- 5 = Spring capsule

101602-3982 4/4

J26

ZEXEL - Test values
Injection pumps



J27

ZEXEL - Test values
Injection pumps



ZEXEL - TEST VALUES
Injection pumps

BOSCH No.	:	9 400 610 210	1/4
ZEXEL No.	:	101602-3991	
Date	:	31.10.1992	[3]
Company	:	KOMATSU	
Engine	:	S6D105 / 6137-72-1331	

IP-Type number : 101060-2470 / PE6A
Governor type number : 105410-7640 / EP/RSV

TEST PREREQUISITES

Test oil : ISO-4113
Test oil inlet temperature °C : 40.00...:45.00
Inlet pressure bar : 1.6
Test nozzle holder combination : 1 688 901 013
Opening pressure bar : 175
Test pressure line
Inner x Outer Dia - Length mm : 2.00 x 6.00 x 600

PORT CLOSING

Prestroke mm : 3.3 ± 0.05
Rod position mm : -
Port closing mark Cyl. No. : -
Cam sequence : 1-5-3-6-2-4

Port closing mark Cyl. No. : -
Port closing difference °NW : 0-60-120-180-240-300

Tolerance +- °C: 0.50 (0.75)

K1

ZEXEL - Test values
Injection pumps



Injection Quantity :

Adjusting Point	Rack Pos. (mm)	P. Speed (rpm)	Injection Q'ty (cm ³ /1000 str.)	Difference (%)	Fixed	Remarks
A	11.5	1050	72.5 ± 1.0	± 2.0	Rack	Basic
H	approx. 7.0	425	7.0 ± 1.0	± 10.0	Rack	
A	11.5	1050	72.5 ± 1.0	-	Lever	Basic

Timing Advance Specification :

Pump Speed (rpm)						
Advance Angle (deg)						

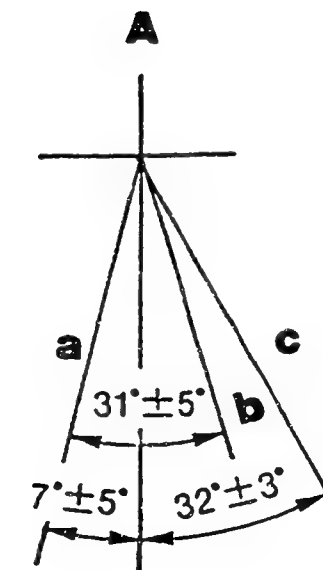
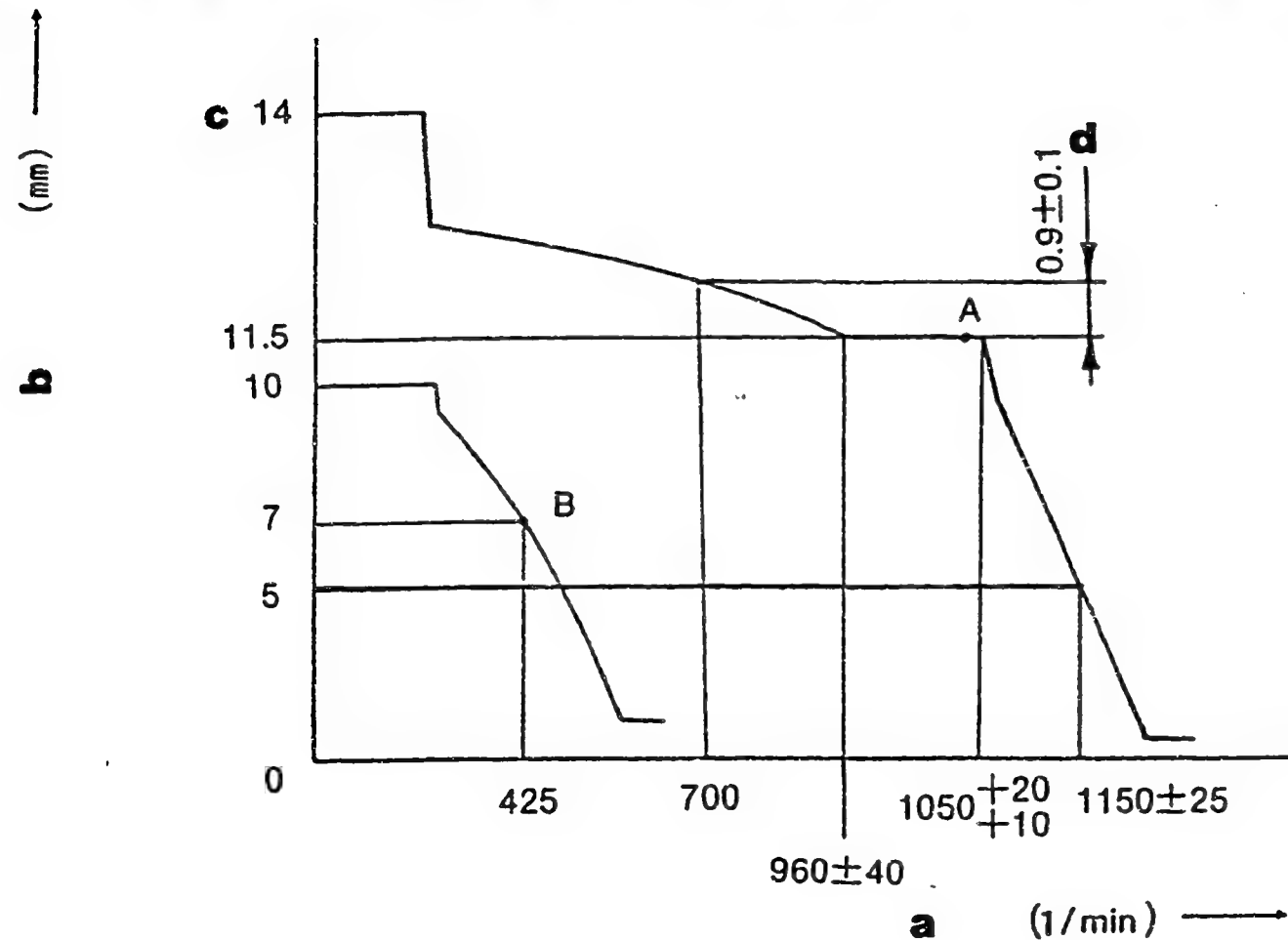

Figure 51

GOVERNOR ADJUSTMENT

101602-3991 2/4

Recommended speed droop adjustment screw position: 15

- a = Pump speed
- b = Control rack position
- c = Above
- d = Difference in control rack position between 1050 rpm and 700 rpm

A = Speed Control Lever Angle

- a = Full-speed
- b = Idling
- c = Stop

K4

ZEXEL - Test values
Injection pumps



K5

ZEXEL - Test values
Injection pumps



■ Note

- Before adjustment, remove the idling sub spring.
- Move the control lever fully in the stop direction, and set the minimum-speed stopper bolt so that the control rack position is 0.5 - 1.0 mm.

■ ADJUSTMENT

	Pump speed (rpm)	Rack position (mm)	Remarks
Full-load Adjustment (Temporary)	1250	11.5	<ul style="list-style-type: none"> • Adjust using screw (2) • Adjust using screw (1)
	600	11.5	
Torque Control spring Adjustment	700	12.4	<ul style="list-style-type: none"> • Adjust using spring capsule (4) • Confirm • Confirm the torque control stroke is 0.9 ± 0.1 mm
	960 ± 40	11.5	
Idling Adjustment	0	10.0	<ul style="list-style-type: none"> • Fix the control lever • Adjust using spring capsule (5) • Confirm
	425	7.0	
Maximum-speed Adjustment	$1050+20$	11.5	<ul style="list-style-type: none"> • Fix the control lever • Confirm speed droop - adjust using screw (3) • Confirm
	$+10$ 1150 ± 25	5.0	
Full-load Adjustment	1050	11.5	<ul style="list-style-type: none"> • Confirm
Control Lever Angle Measurement	<ul style="list-style-type: none"> • Measure the control lever angle at the "idling" and "full" positions. • When the control lever is depressed toward the "full" position, replace the shifter's shim with a thicker one. • When the control lever is depressed toward the "idling" position, replace the shifter's shim with a thinner one. 		
Rack Limiter Adjustment	-	-	<ul style="list-style-type: none"> • Adjust using screw

K6

ZEXEL - Test values
Injection pumps



K7

ZEXEL - Test values
Injection pumps



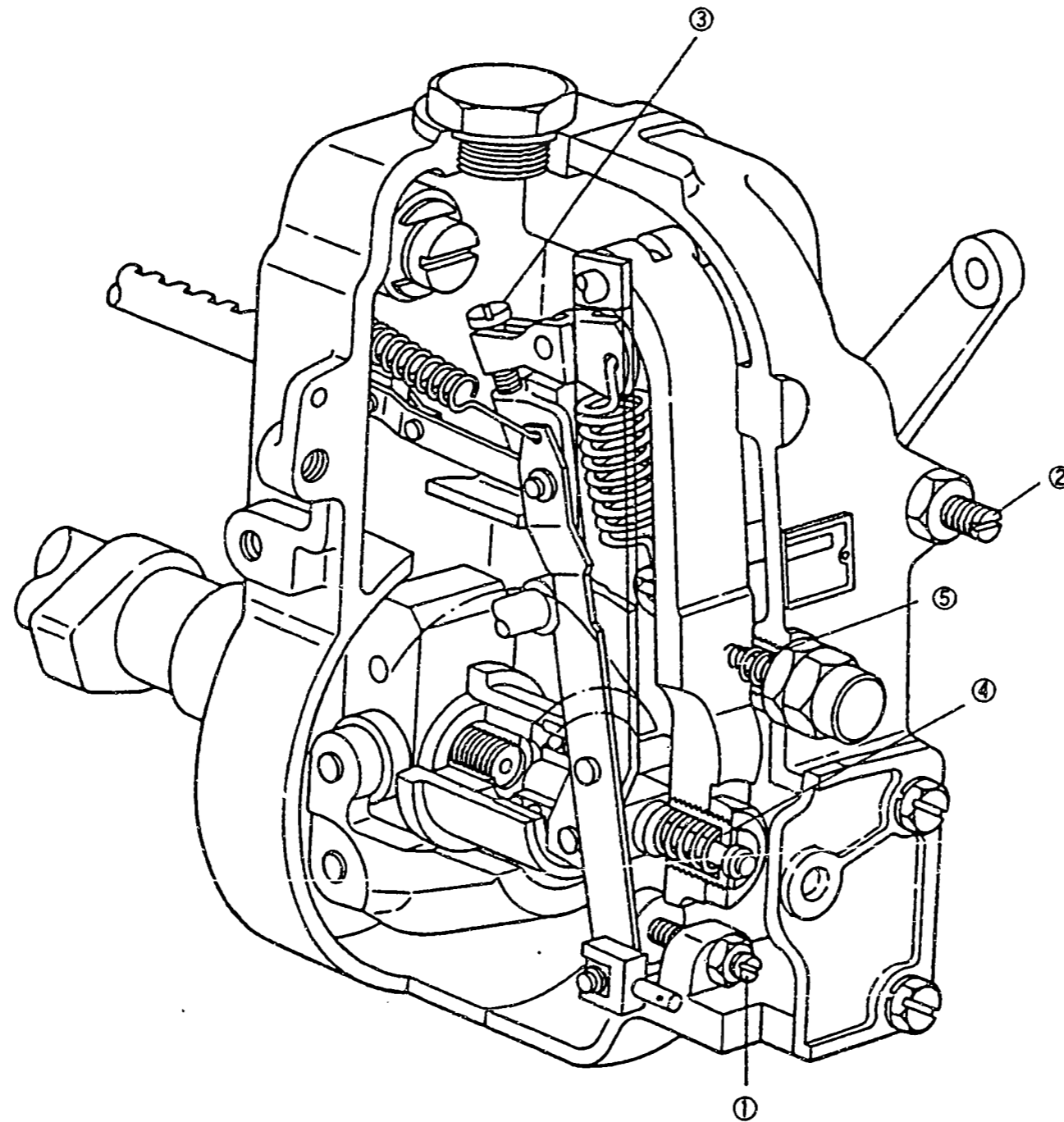

Figure 52

- 1 = Screw
- 2 = Screw
- 3 = Screw
- 4 = Spring capsule
- 5 = Spring capsule

K8

ZEXEL - Test values
Injection pumps



K9

ZEXEL - Test values
Injection pumps



ZEXEL - TEST VALUES
Injection pumps

BOSCH No.	:	9 400 610 139	1/4
ZEXEL No.	:	101605-3001	
Date	:	31.10.1992	[6]
Company	:	KOMATSU	
Engine	:	S6D105 / 6137-72-1190	

IP-Type number : 101060-2470 / PE 6A
Governor type number : 105411-0930 / EP/RSV

TEST PREREQUISITES

Test oil : ISO-4113
Test oil inlet temperature °C : 40.00...45.00
Inlet pressure bar : 1.6
Test nozzle holder combination : 1 688 901 013
Opening pressure bar : 175
Test pressure line
Inner x Outer Dia - Length mm : 2.00 x 6.00 x 600

PORT CLOSING

Prestroke mm : 3.3 ± 0.05
Rod position mm : -
Port closing mark Cyl. No. : -
Cam sequence : 1-5-3-6-2-4

Port closing mark Cyl. No. : -
Port closing difference °NW : 0-60-120-180-240-300

Tolerance +- °C: 0.50 (0.75)

K10

ZEXEL - Test values
Injection pumps



Injection Quantity :

Adjusting Point	Rack Pos. (mm)	P. Speed (rpm)	Injection Q'ty (cm ³ /1000 str.)	Difference (%)	Fixed	Remarks
A	10.5	1150	70.5 ± 1.0	± 2.0	Lever	
H	approx. 8.0	365	9.6 ± 1.5	± 10.0	Rack	
A	10.5	1150	70.5 ± 1.0	-	Lever	Basic Boost press. kPa (mmHg) above 33.3 (above 250)

Timing Advance Specification :

Pump Speed (rpm)					
Advance Angle (deg)					



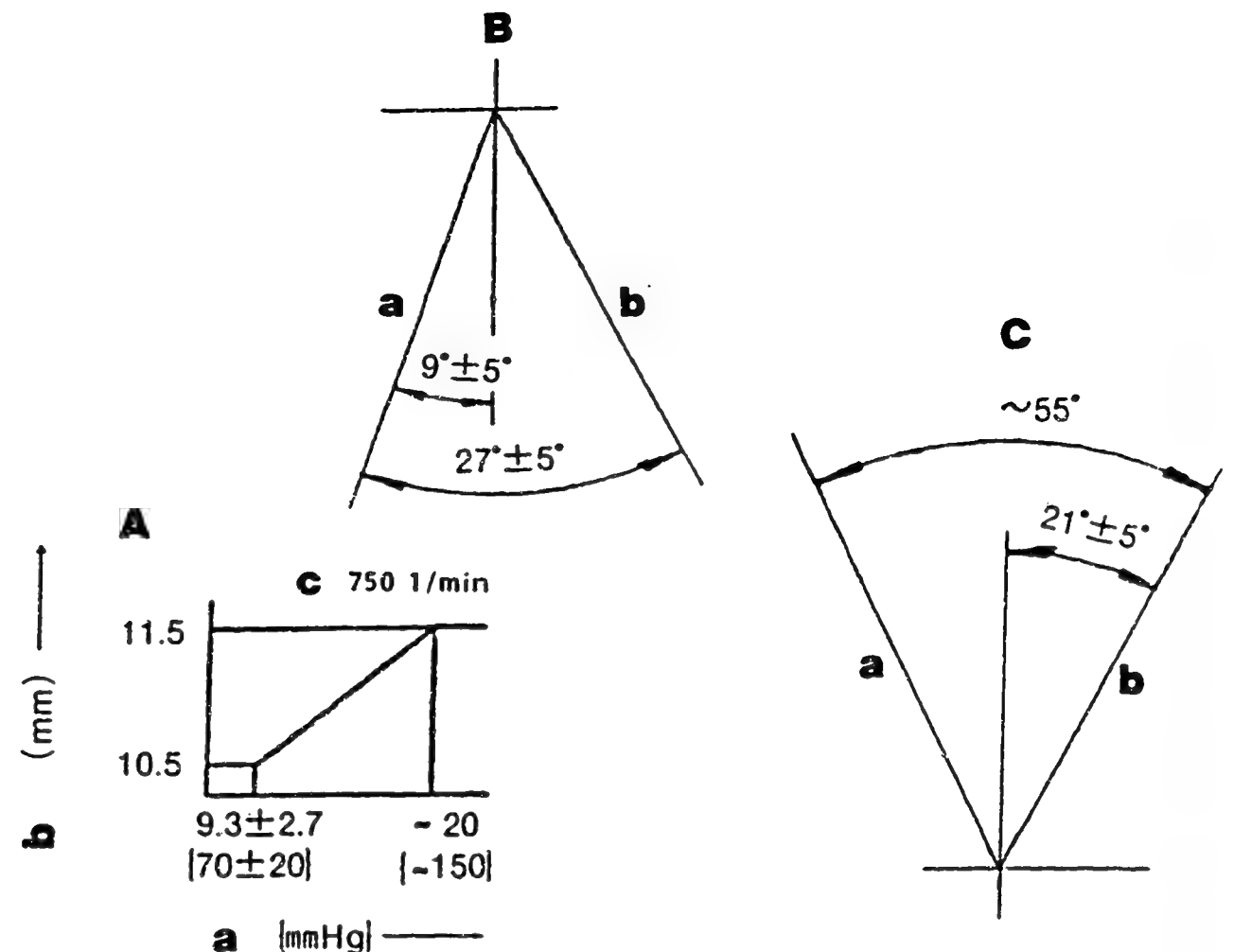
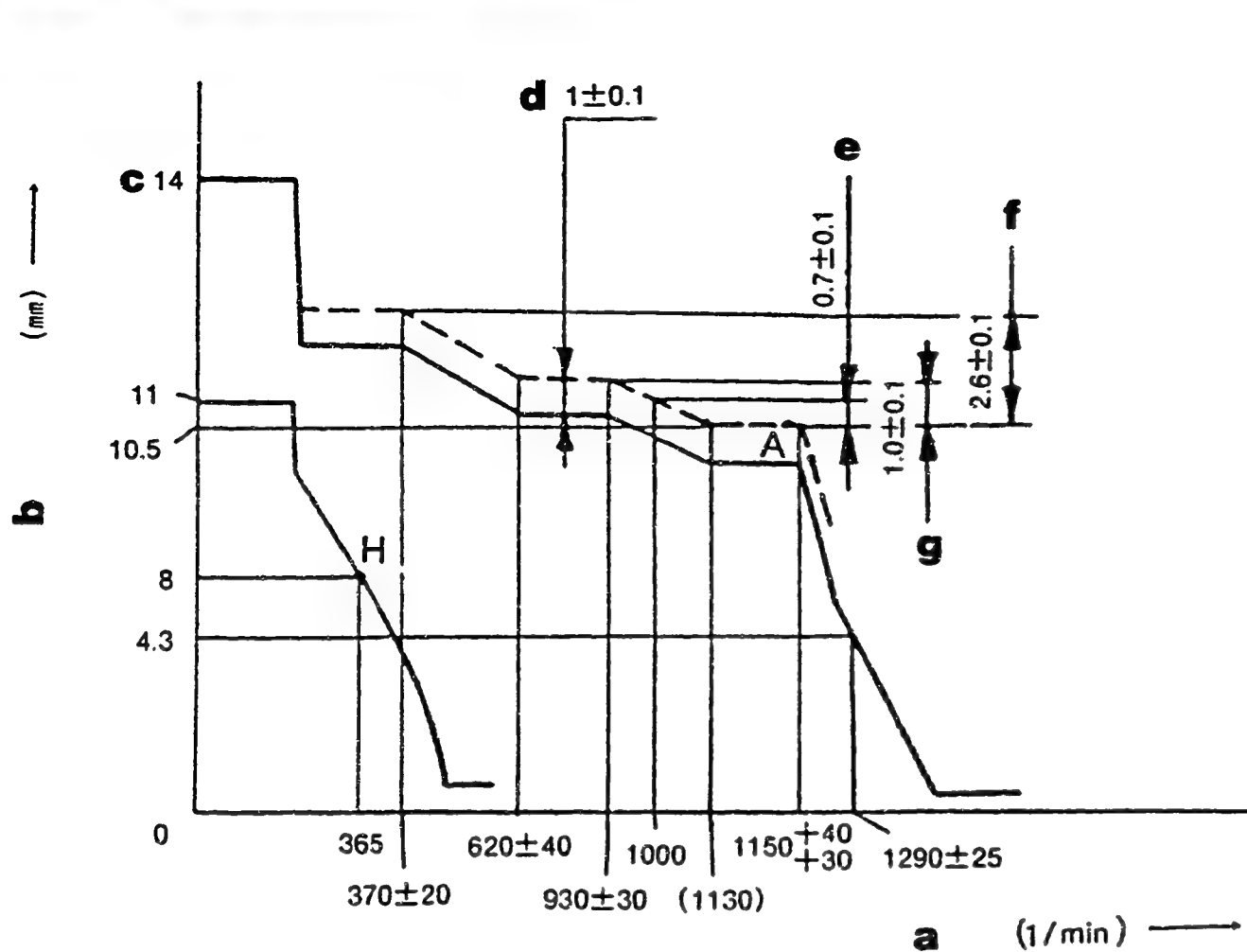

Figure 53 GOVERNOR ADJUSTMENT

Recommended speed droop adjustment screw position: 10

101605-3001 2/4

- a = Pump speed
- b = Control rack position
- c = Above
- d = Boost compensator stroke:
- e = Difference in control rack position between 1150 rpm and 1000 rpm
- f = Difference in control rack position between 1150 rpm and 350 rpm
- g = Difference in control rack position between 1150 rpm and 800 rpm

- A** = BOOST COMPENSATOR ADJUSTMENT
- a = Boost pressure
- b = Control rack position
- c = Pump speed:
- B** = Speed Control Lever Angle
- a = Full-speed
- b = Idling
- C** = Stop Lever Angle
- a = Normal
- b = Stop

K13

ZEXEL - Test values
Injection pumps



K14

ZEXEL - Test values
Injection pumps



■ Note

- Before adjustment, remove the idling sub spring.
- Move the control lever fully in the stop direction, and set the minimum-speed stopper bolt so that the control rack position is 0.5 - 1.0 mm.

■ ADJUSTMENT

		Pump Speed (rpm)	Rack Position (mm)	Boost pressure kPa (mmHg)	Remarks
Full-load Adjustment (Temporary)		1350 600	10.5 10.5	0 0	<ul style="list-style-type: none"> • Adjust using screw (2) • Adjust using screw (1)
Torque Control Spring Adjust- ment	1.st stroke	approx. 270	13.1	0	<ul style="list-style-type: none"> • Adjust using spring capsule (4) • Confirm • Confirm the torque control stroke is: 1.6 ± 0.1 mm
		370 ± 20	13.1	0	
		620 ± 40	11.5	0	
	2.st stroke	approx. 830	11.5	0	<ul style="list-style-type: none"> • Adjust using spring capsule (4) • Confirm • Confirm the torque control stroke is: 1.0 ± 0.1 mm
		1000	11.2	0	
		approx. 1130	10.5	0	
Maximum Speed Adjustment		1150+40 +30 1290 ± 25	10.5 4.3	0 0	<ul style="list-style-type: none"> • Fix the control lever • Confirm speed droop - adjust using screw (3) • Confirm
Boost Compensator System		750 750	10.5 11.5	9.3 ± 2.7 (70 ± 20) approx. 20 (approx. 150)	<ul style="list-style-type: none"> • Fix the control lever • Adjust using screw (6) • Confirm the boost compensator stroke is: 1.0 ± 0.1 mm
Idling Adjustment		0	11.0	0	<ul style="list-style-type: none"> • Fix the control lever • Adjust using spring capsule (5) • Confirm • Adjust using the control lever
1. Idling Sub Spring	H	365	8.0	0	
2. Control Lever	-	-	-	-	
Full-load Adjustment		1150	10.5	above 33.3 (above 250)	<ul style="list-style-type: none"> • Confirm
Control Lever Angle Measurement		<ul style="list-style-type: none"> • Measure the control lever angle at the "idling" and "full" positions. • When the control lever is depressed toward the "full" position, replace the shifter's shim with a thicker one. • When the control lever is depressed toward the "idling" position, replace the shifter's shim with a thinner one. 			
Control Rack Limiter Adjustment		-	-	-	<ul style="list-style-type: none"> • Adjust using screw

K15

ZEXEL - Test values

Injection pumps



K16

ZEXEL - Test values

Injection pumps



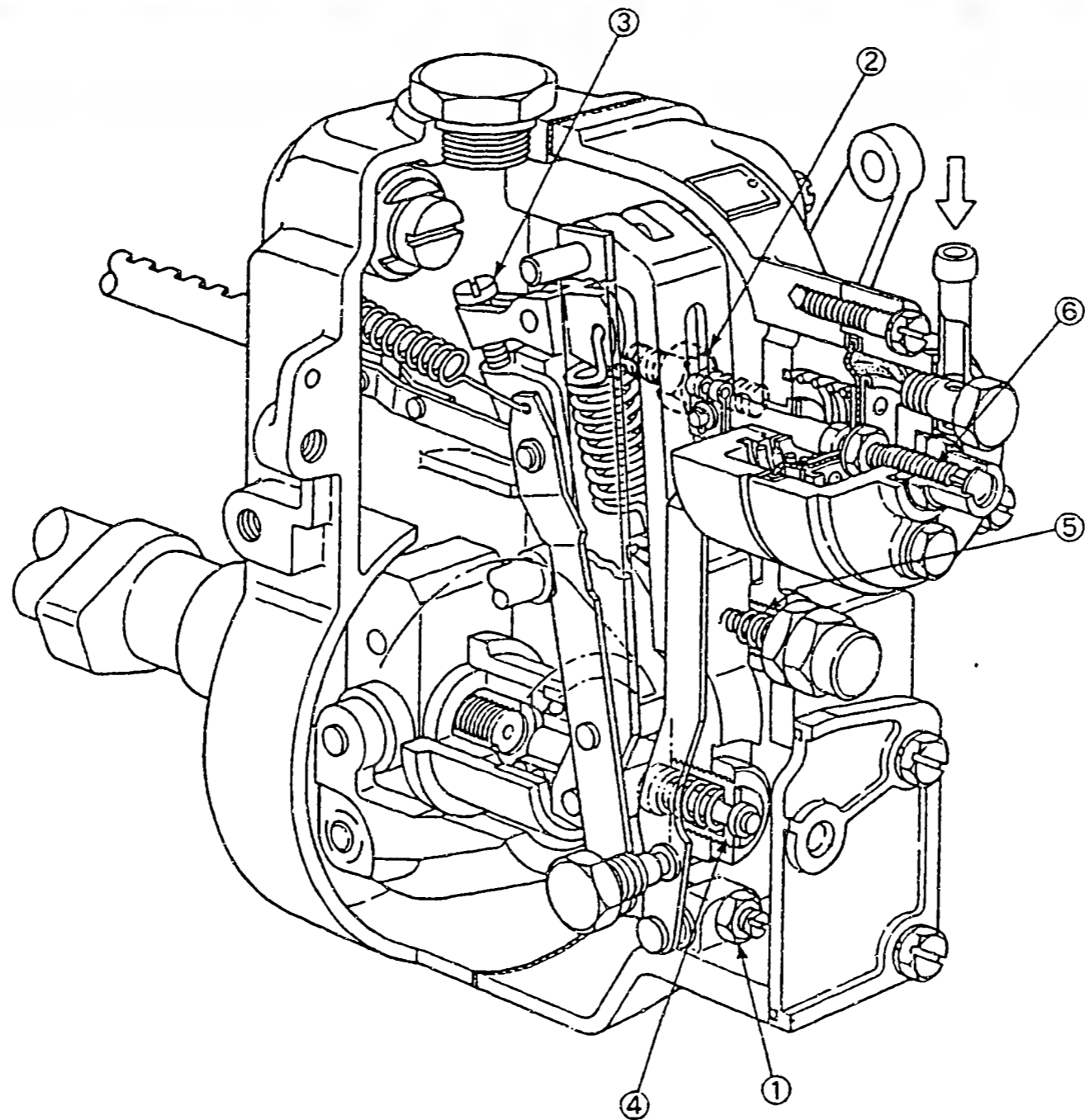

Figure 54

- 1 = Screw
- 2 = Screw
- 3 = Screw
- 4 = Spring capsule
- 5 = Spring capsule
- 6 = Screw

101605-3001 4/4

K17

ZEXEL - Test values
Injection pumps



K18

ZEXEL - Test values
Injection pumps

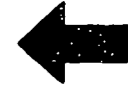

ZEXEL - TEST VALUES
Injection pumps

BOSCH No.	:	9 400 610 211	1/4
ZEXEL No.	:	101605-3101	
Date	:	31.10.1992	[1]
Company	:	KOMATSU	
Engine	:	SA6D110 / 6138-72-1440	

IP-Type number : 101060-4110 / PE 6AD
Governor type number : 105410-7771 / EP/RSV

TEST PREREQUISITES

Test oil : ISO-4113
Test oil inlet temperature °C : 40.00...45.00
Inlet pressure bar : 1.6
Test nozzle holder combination : 1 688 901 013
Opening pressure bar : 175
Test pressure line
Inner x Outer Dia - Length mm : 2.00 x 6.00 x 600

PORT CLOSING

Prestroke mm : 4.0 ± 0.05
Rod position mm : -
Port closing mark Cyl. No. : -
Cam sequence : 1-5-3-6-2-4

Port closing mark Cyl. No. : -
Port closing difference °NW : 0-60-120-180-240-300

Tolerance +- °C: 0.50 (0.75)

K19

ZEXEL - Test values
Injection pumps



Injection Quantity :

Adjusting Point	Rack Pos. (mm)	P. Speed (rpm)	Injection Q'ty (cm ³ /1000 str.)	Difference (%)	Fixed	Remarks
A	9.6	900	88.5 ± 1.0	± 2.0	Rack	Basic
H	approx. 7.3	375	13.0	-	Rack	
A	9.6	900	88.5 ± 1.0	-	Lever	Basic
B	(6.5)	930	20.0 ± 2.0	± 10.0	Lever	

Timing Advance Specification :

Pump Speed (rpm)						
Advance Angle (deg)						

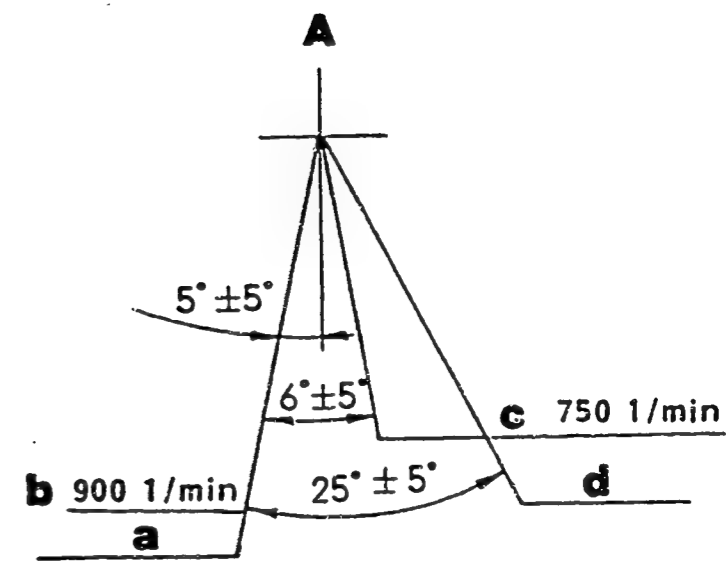
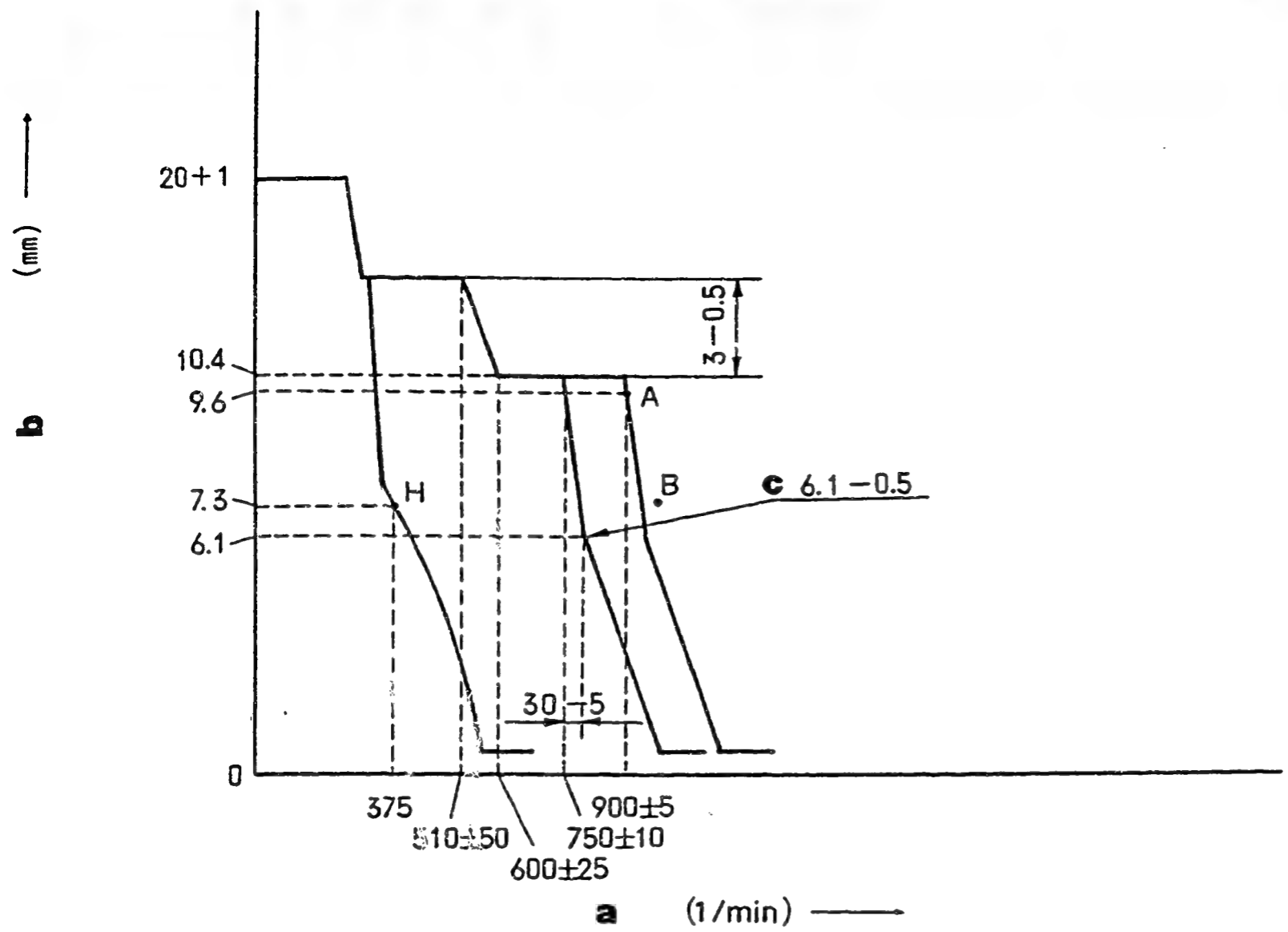

Figure 55

GOVERNOR ADJUSTMENT

101605-3101 2/4

Recommended speed droop adjustment screw position: 16

- a = Pump speed
- b = Control rack position
- c = Idle-sub spring setting:

A = Speed Control Lever Angle

- a = Full-speed
- b = Setting:
(on our shipment)
- c = Setting:
- d = Idling

K22

ZEXEL - Test values
Injection pumps



K23

ZEXEL - Test values
Injection pumps



■ Note

- Before adjustment, remove the idling sub spring.
- Move the control lever fully in the stop direction, and set the minimum-speed stopper bolt so that the control rack position is 0.5 - 1.0 mm.

■ ADJUSTMENT

	Pump speed (rpm)	Rack position (mm)	Remarks
Full-load Adjustment (Temporary)	1100	9.6	<ul style="list-style-type: none"> • Adjust using screw (2) • Adjust using screw (1)
	600	10.4	
Torque Control spring Adjustment	400	13.4	<ul style="list-style-type: none"> • Adjust using spring capsule (4) • Confirm • Confirm the torque control stroke is: 3.0 -0.5 mm
	510 ± 50	13.4	
	600 ± 25	10.4	
Idling Adjustment	375	7.3	<ul style="list-style-type: none"> • Adjust using control lever
Maximum-speed Adjustment	750 ± 10	9.6	<ul style="list-style-type: none"> • Fix the control lever • Confirm speed droop - adjust using screw (3) • Confirm • Adjust using screw (2)
	750+30	6.1	
	+25		
	900 ± 5	9.6	
Full-load Adjustment	850	10.4	<ul style="list-style-type: none"> • Confirm
Control Lever Angle Measurement	<ul style="list-style-type: none"> • Measure the control lever angle at the "idling" and "full" positions. • When the control lever is depressed toward the "full" position, replace the shifter's shim with a thicker one. • When the control lever is depressed toward the "idling" position, replace the shifter's shim with a thinner one. 		
Rack Limiter Adjustment	-	-	<ul style="list-style-type: none"> • Adjust using screw

K24

ZEXEL - Test values
Injection pumps



K25

ZEXEL - Test values
Injection pumps



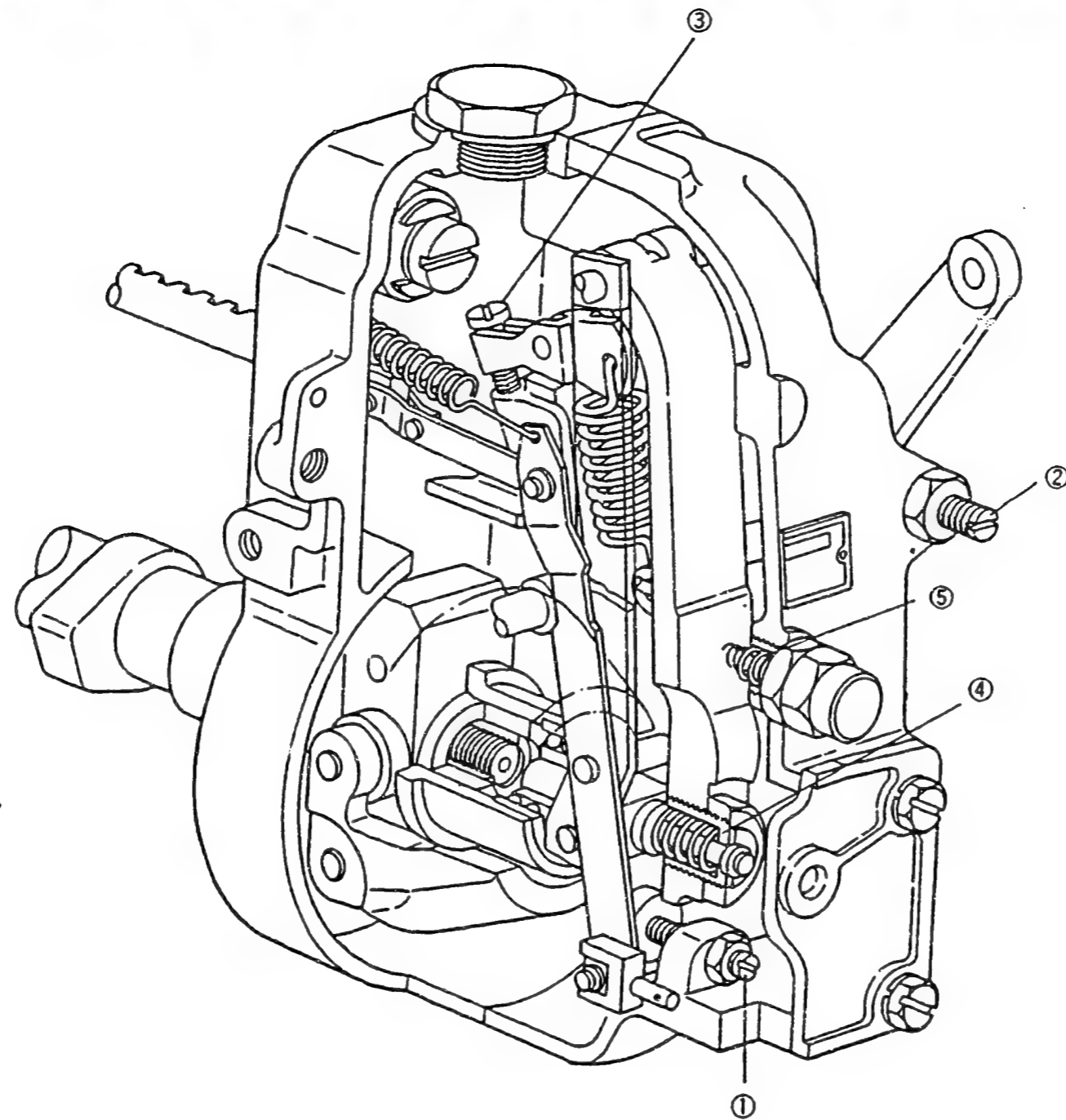

Figure 56

- 1 = Screw
- 2 = Screw
- 3 = Screw
- 4 = Spring capsule
- 5 = Spring capsule

101605-3101 4/4

K 26

ZEXEL - Test values
Injection pumps



K 27

ZEXEL - Test values
Injection pumps



ZEXEL - TEST VALUES
Injection pumps

BOSCH No.	: 9 400 610 212	1/4
ZEXEL No.	: 101605-3140	
Date	: 31.10.1992	[1]
Company	: KOMATSU	
Engine	: S6D105 / 6137-72-1660	

IP-Type number : 101060-2530 / PE 6A
Governor type number : 105410-7880 / EP/RSV

TEST PREREQUISITES

Test oil : ISO-4113
Test oil inlet temperature °C : 40.00...45.00
Inlet pressure bar : 1.6
Test nozzle holder combination : 1 688 901 013
Opening pressure bar : 175
Test pressure line
Inner x Outer Dia - Length mm : 2.00 x 6.00 x 600

PORT CLOSING

Prestroke mm : 3.3 ± 0.05
Rod position mm : -
Port closing mark Cyl. No. : -
Cam sequence : 1-5-3-6-2-4

Port closing mark Cyl. No. : -
Port closing difference °NW : 0-60-120-180-240-300

Tolerance +- °C: 0.50 (0.75)



Injection Quantity :

Adjusting Point	Rack Pos. (mm)	P. Speed (rpm)	Injection Q'ty (cm ³ /1000 str.)	Difference (%)	Fixed	Remarks
A	11.5	750	104.0 ± 1.0	± 2.0	Rack	Basic
H	approx. 8.0	350	10.0 ± 1.5	± 10.0	Rack	
A	11.5	750	104.0 ± 1.0	-	Lever	Basic

Timing Advance Specification :

Pump Speed (rpm)						
Advance Angle (deg)						

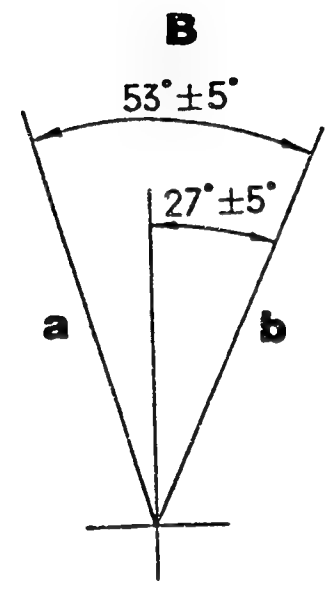
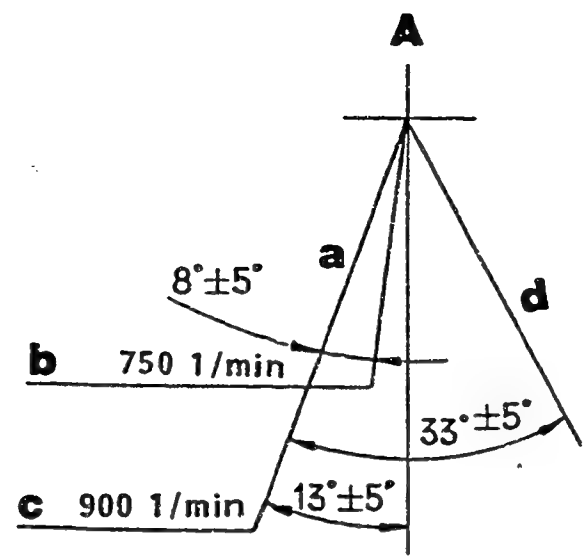
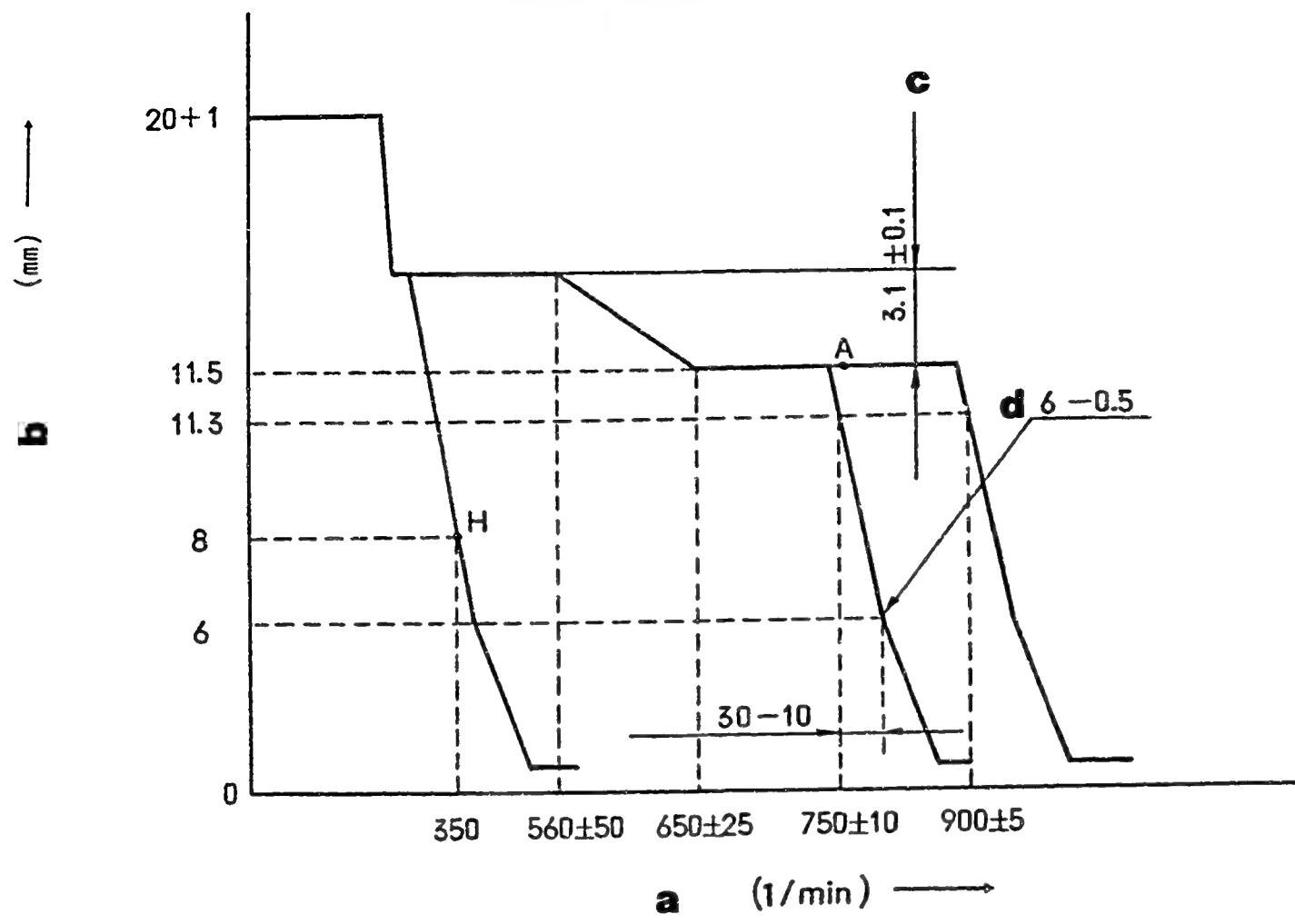

Figure 57

GOVERNOR ADJUSTMENT

101605-3140 2/4

Recommended speed droop adjustment screw position: 15

- a = Pump speed
- b = Control rack position
- c = Difference in control rack position between 800 rpm and 500 rpm
- d = Idle-sub spring setting:

- A = Speed Control Lever Angle
- a = Full-speed
- b = Setting:
- c = Setting: (On our shipment)
- d = Idling

- B = Stop Lever Angle
- a = Stop
- b = Normal

■ Note

- Before adjustment, remove the idling sub spring.
- Move the control lever fully in the stop direction, and set the minimum-speed stopper bolt so that the control rack position is 0.5 - 1.0 mm.

■ ADJUSTMENT

	Pump speed (rpm)	Rack position (mm)	Remarks
Full-load Adjustment (Temporary)	1100	11.3	<ul style="list-style-type: none"> • Adjust using screw (2) • Adjust using screw (1)
	600	11.5	
Torque Control spring Adjustment	450	14.6	<ul style="list-style-type: none"> • Adjust using spring capsule (4) • Confirm • Confirm the torque control stroke is: 3.1 ± 0.1 mm
	560 ± 50	14.6	
	650 ± 25	11.5	
Idling Adjustment	350	8.0	<ul style="list-style-type: none"> • Adjust using control lever
Maximum-speed Adjustment	750 ± 10	11.3	<ul style="list-style-type: none"> • Fix the control lever • Confirm speed droop - adjust using screw (3) • Confirm
	750+30	6 -0.5	
	+20		
	900 ± 5		
Full-load Adjustment	850	11.5	<ul style="list-style-type: none"> • Confirm
Control Lever Angle Measurement	<ul style="list-style-type: none"> • Measure the control lever angle at the "idling" and "full" positions. • When the control lever is depressed toward the "full" position, replace the shifter's shim with a thicker one. • When the control lever is depressed toward the "idling" position, replace the shifter's shim with a thinner one. 		
Rack Limiter Adjustment	-	-	<ul style="list-style-type: none"> • Adjust using screw

L6

ZEXEL - Test values

Injection pumps



L7

ZEXEL - Test values

Injection pumps



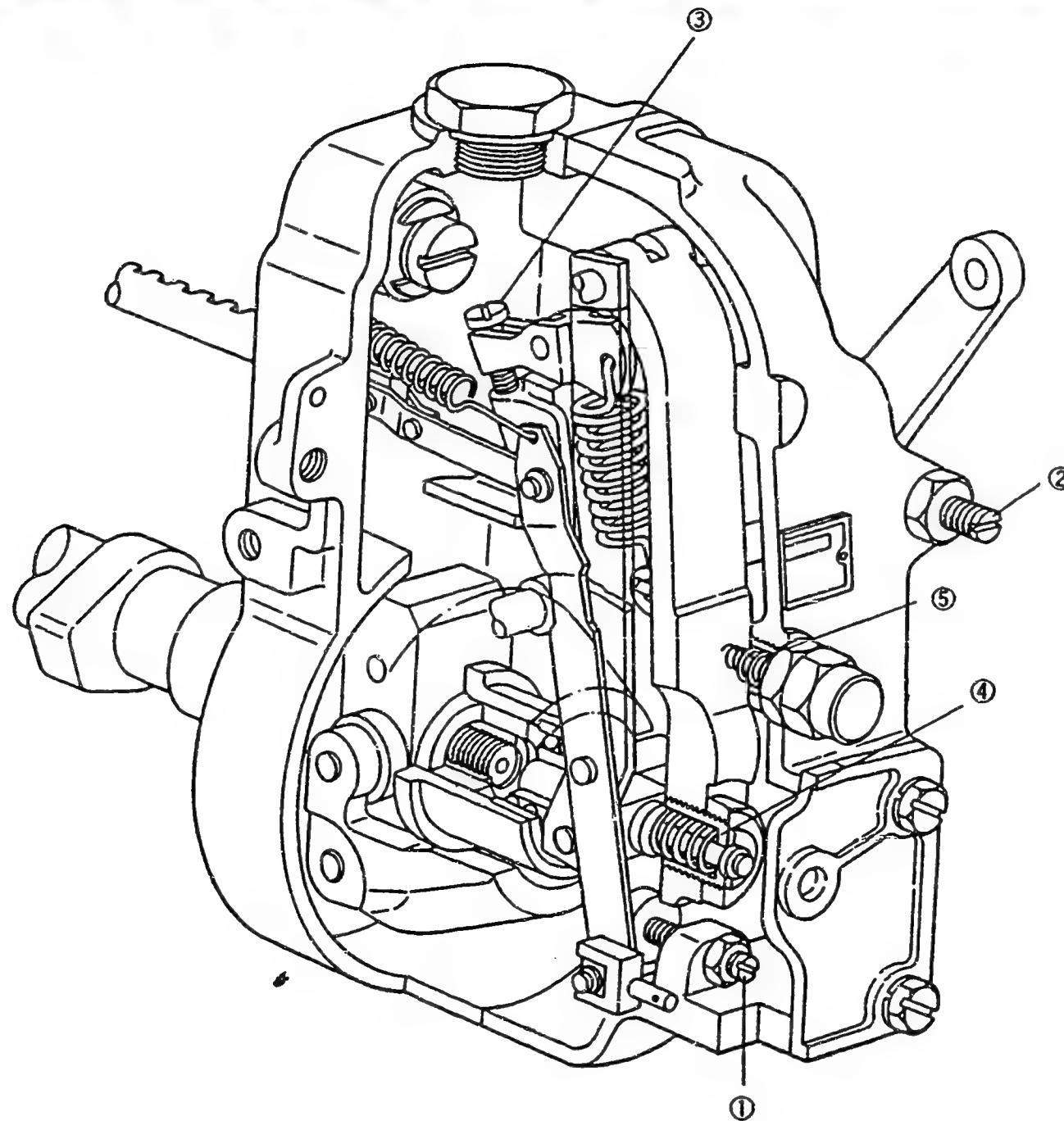

Figure 58

- 1 = Screw
- 2 = Screw
- 3 = Screw
- 4 = Spring capsule
- 5 = Spring capsule

101605-3140 4/4

L8

ZEXEL - Test values
Injection pumps



L9

ZEXEL - Test values
Injection pumps



ZEXEL - TEST VALUES

Injection pumps

BOSCH No.	: 9 400 610 213	1/4
ZEXEL No.	: 101605-3401	
Date	: 31.10.1992	[3]
Company	: KOMATSU	
Engine	: S6D110 / 6138-72-1330	

IP-Type number : 101060-4370 / PE 6AD
 Governor type number : 105411-1171 / EP/RSV

TEST PREREQUISITES

Test oil : ISO-4113
 Test oil inlet temperature °C : 40.00...45.00
 Inlet pressure bar : 1.6
 Test nozzle holder combination : 1 688 901 013
 Opening pressure bar : 175
 Test pressure line
 Inner x Outer Dia - Length mm : 2.00 x 6.00 x 600

PORT CLOSING

Prestroke mm : 4.0 ± 0.05
 Rod position mm : -
 Port closing mark Cyl. No. : -
 Cam sequence : 1-5-3-6-2-4

 Port closing mark Cyl. No. : -
 Port closing difference °NW : 0-60-120-180-240-300

 Tolerance +- °C: 0.50 (0.75)

Injection Quantity :

Adjusting Point	Rack Pos. (mm)	P. Speed (rpm)	Injection Q'ty (cm ³ /1000 str.)	Difference (%)	Fixed	Remarks
A	10.2	1100	80.9 ± 1.0	± 2.0	Rack	Basic
	approx. 8.0	350	12.3 ± 1.2	± 10.0	Rack	
A	10.2	1100	80.9 ± 1.0	-	Lever	Basic Boost press. kPa (mmHg) above 40.7 (above 300)
B	11.5	750	92.9 ± 2.0	-	Lever	Boost press. kPa (mmHg) above 40.7 (above 300)

Timing Advance Specification :

Pump Speed (rpm)					
Advance Angle (deg)					



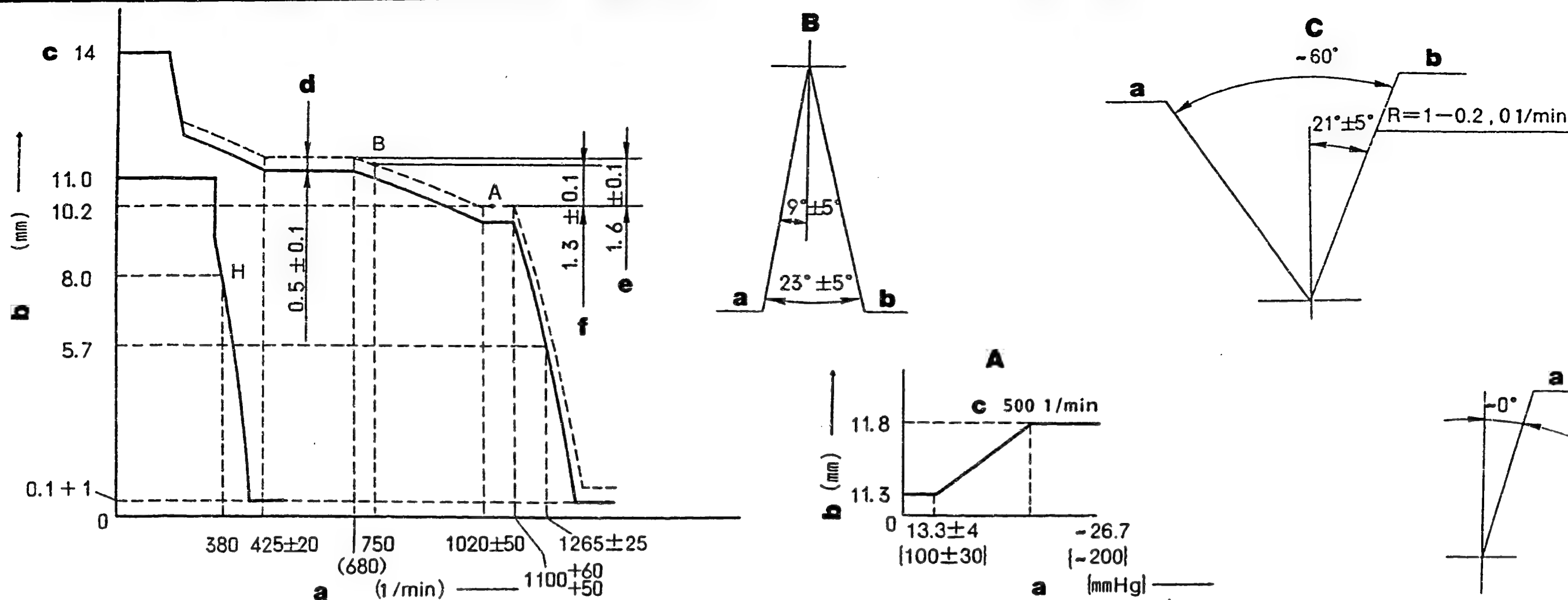

Figure 59 GOVERNOR ADJUSTMENT

Recommended speed droop adjustment screw position: 16

101605-3401 2/4

- a = Pump speed
- b = Control rack position
- c = Above
- d = Boost compensator stroke:
- e = Difference in control rack position between 1100 rpm and 500 rpm
- f = Difference in control rack position between 1100 rpm and 750 rpm

A = BOOST COMPENSATOR ADJUSTMENT

- a = Boost pressure
- b = Control rack position
- c = Perform at:

B = Speed Control Lever Angle

- a = Full-speed
- b = Idling

C = Stop Lever Angle

- a = Normal
- b = Stop

■ TIMING SETTING

At No. 1 plunger's beginning of injection position.

a = Coupling key groove position

L13

ZEXEL - Test values
Injection pumps



L14

ZEXEL - Test values
Injection pumps



■ Note

- Before adjustment, remove the idling sub spring.
- Move the control lever fully in the stop direction, and set the minimum-speed stopper bolt so that the control rack position is 0.5 - 1.0 mm.

■ ADJUSTMENT

		Pump Speed (rpm)	Rack Position (mm)	Boost pressure kPa (mmHg)	Remarks
Full-load Adjustment (Temporary)		1300	10.2	-	• Adjust using screw (2)
		600	10.2		• Adjust using screw (1)
Torque Control Spring Adjust- ment	1.st stroke	580	11.8	-	• Adjust using spring capsule (4)
		approx. 680	11.8		• Confirm
		750	11.5		• Confirm the torque control stroke is: 1.6 ± 0.1 mm
	1020 \pm 50	10.2			
					• Adjust using spring capsule (4)
					• Confirm
					• Confirm the torque control stroke is: (mm)
Maximum Speed Adjustment		1100 \pm 60	10.2	0	• Fix the control lever
		+50			• Confirm speed droop - adjust using screw (3)
		1265 \pm 25	5.7		• Confirm
Boost Compensator System		500	13.3 \pm 4 (100 \pm 30)	11.3	• Adjust using screw (6)
		500	approx. 26.7 (approx. 200)	11.8	• Confirm the boost compensator stroke is: 0.5 ± 0.1 mm
Idling Adjustment		0	11.4		• Fix the control lever
1. Idling Sub Spring	H	380	8.0		• Adjust using spring capsule (5)
		above 450	0.1+1		• Confirm
2. Control Lever					• Adjust using the control lever
Full-load Adjustment		1100	10.2		• Confirm
Control Lever Angle Measurement		<ul style="list-style-type: none"> • Measure the control lever angle at the "idling" and "full" positions. • When the control lever is depressed toward the "full" position, replace the shifter's shim with a thicker one. • When the control lever is depressed toward the "idling" position, replace the shifter's shim with a thinner one. 			
Control Rack Limiter Adjustment		-	-	-	• Adjust using screw

L15

ZEXEL - Test values
Injection pumps



L16

ZEXEL - Test values
Injection pumps



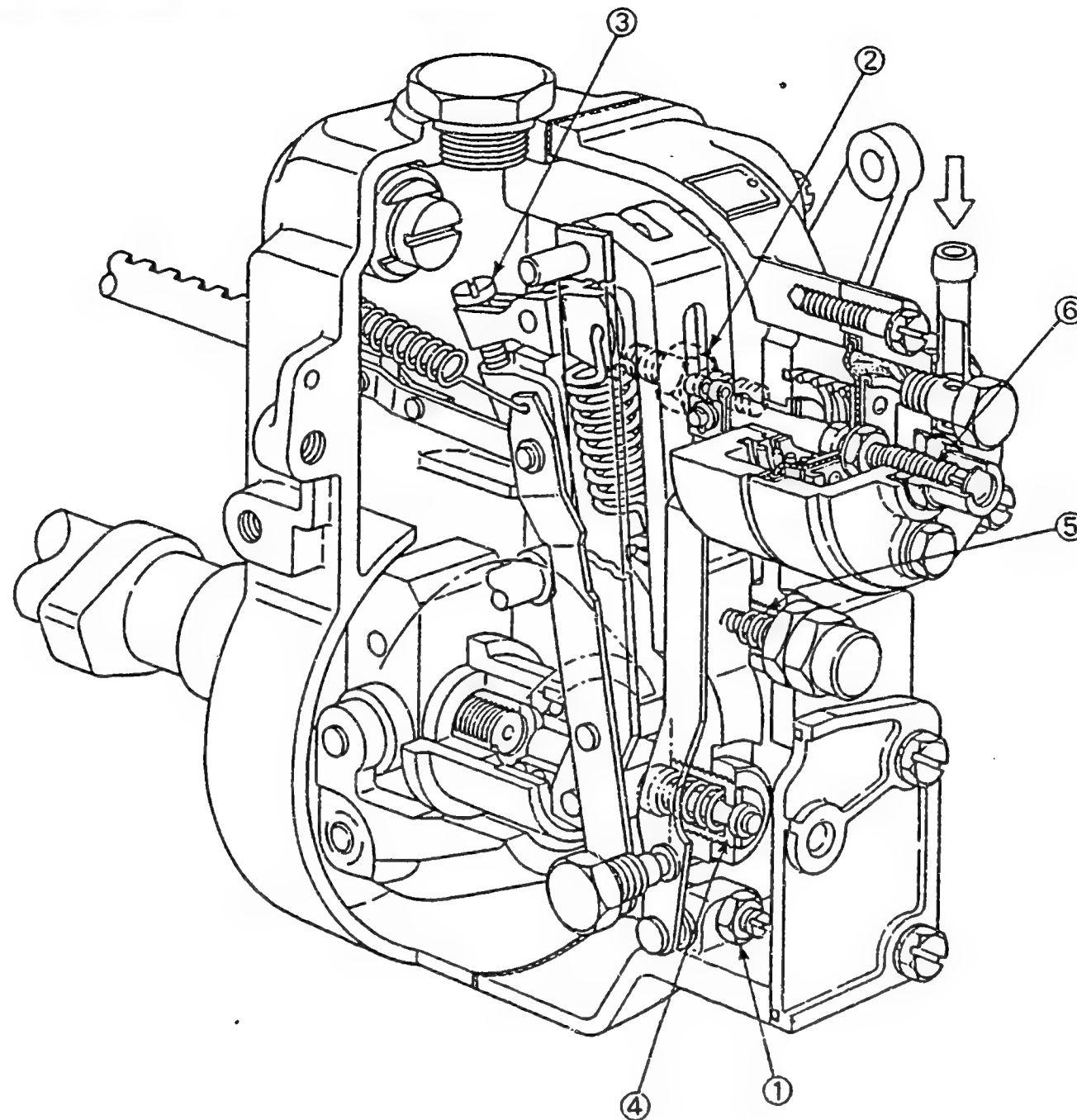

Figure 60

- 1 = Screw
- 2 = Screw
- 3 = Screw
- 4 = Spring capsule
- 5 = Spring capsule
- 6 = Screw

101605-3401 4/4

L17

ZEXEL - Test values
Injection pumps



L18

ZEXEL - Test values
Injection pumps



ZEXEL - TEST VALUES
Injection pumps

BOSCH No.	:	9 400 610 214	1/4
ZEXEL No.	:	101605-3561	
Date	:	31.10.1992	[2]
Company	:	KOMATSU	
Engine	:	S6D110 / 6138-72-1340	

IP-Type number : 101060-4480 / PE 6AD
Governor type number : 105410-9271 / EP/RSV

TEST PREREQUISITES

Test oil : ISO-4113
Test oil inlet temperature °C : 40.00...45.00
Inlet pressure bar : 1.6
Test nozzle holder combination : 1 688 901 013
Opening pressure bar : 175
Test pressure line
Inner x Outer Dia - Length mm : 2.00 x 6.00 x 600

PORT CLOSING

Prestroke mm : 4.0 ± 0.05
Rod position mm : -
Port closing mark Cyl. No. : -
Cam sequence : 1-5-3-6-2-4

Port closing mark Cyl. No. : -
Port closing difference °NW : 0-60-120-180-240-300

Tolerance +- °C: 0.50 (0.75)



Injection Quantity :

Adjusting Point	Rack Pos. (mm)	P. Speed (rpm)	Injection Q'ty (cm ³ /1000 str.)	Difference (%)	Fixed	Remarks
A	9.8	1050	78.7 ± 1.0	± 2.0	Rack	Basic
H	approx. 8.0	425	13.1 ± 1.2	± 10.0	Rack	
A	9.8	1050	78.7 ± 1.0	-	Lever	Basic
B	10.3	700	(80.5 ± 2.0)	-	Lever	

Timing Advance Specification :

Pump Speed (rpm)						
Advance Angle (deg)						

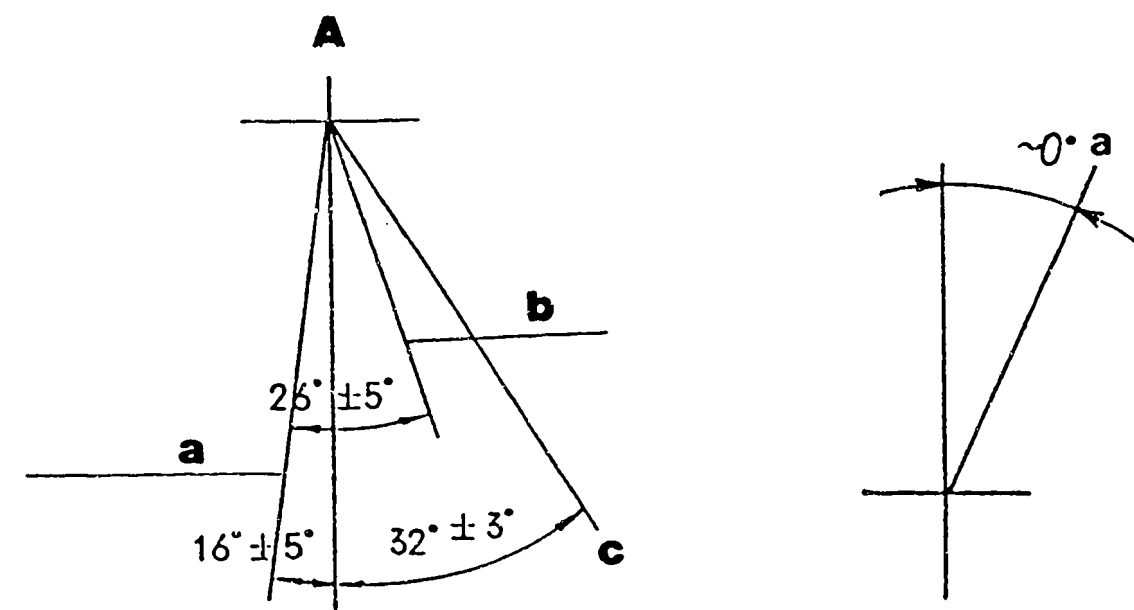
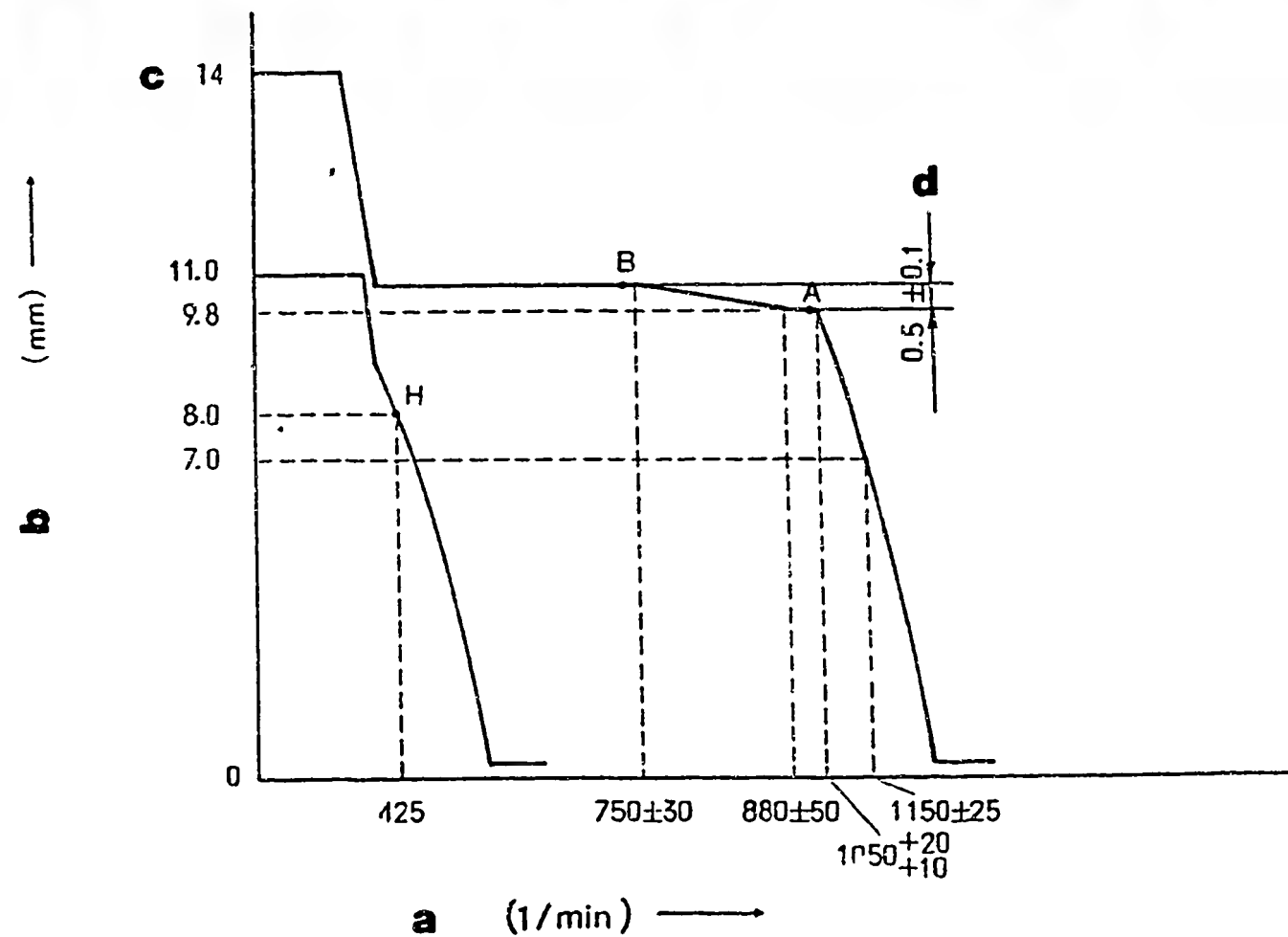

Figure 61

GOVERNOR ADJUSTMENT

101605-3561 2/4

Recommended speed droop adjustment screw position: above 18

- a = Pump speed
- b = Control rack position
- c = Above
- d = Difference in control rack position between 1050 rpm and 700 rpm

A = Speed Control Lever Angle

- a = Full-speed
- b = Idling
- c = Stop

■ TIMING SETTING

At No. 1 plunger's beginning of injection position.

a = Coupling key groove position

L22

ZEXEL - Test values
Injection pumps



L23

ZEXEL - Test values
Injection pumps

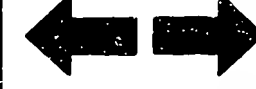

■ Note

- Before adjustment, remove the idling sub spring.
- Move the control lever fully in the stop direction, and set the minimum-speed stopper bolt so that the control rack position is 0.5 - 1.0 mm.

■ ADJUSTMENT

	Pump speed (rpm)	Rack position (mm)	Remarks
Full-load Adjustment (Temporary)	1250	9.8	<ul style="list-style-type: none"> • Adjust using screw (2) • Adjust using screw (1)
	600	9.8	
Torque Control spring Adjustment	650	10.3	<ul style="list-style-type: none"> • Adjust using spring capsule (4) • Confirm • Confirm the torque control stroke is: 0.7 ± 0.1 mm
	750 ± 30	10.3	
	880 ± 50	9.8	
Idling Adjustment	0	11.0	<ul style="list-style-type: none"> • Fix the control lever • Adjust using spring capsule (5) • Confirm
	425	8.0	
Maximum-speed Adjustment	$1050+20$	9.8	<ul style="list-style-type: none"> • Fix the control lever • Confirm speed droop - adjust using screw (3) • Confirm
	$+10$ 1150 ± 25	7.0	
Full-load Adjustment	1050	9.8	<ul style="list-style-type: none"> • Confirm
Control Lever Angle Measurement	<ul style="list-style-type: none"> • Measure the control lever angle at the "idling" and "full" positions. • When the control lever is depressed toward the "full" position, replace the shifter's shim with a thicker one. • When the control lever is depressed toward the "idling" position, replace the shifter's shim with a thinner one. 		
Rack Limiter Adjustment	-	-	<ul style="list-style-type: none"> • Adjust using screw

L24

ZEXEL - Test values
Injection pumps



L25

ZEXEL - Test values
Injection pumps



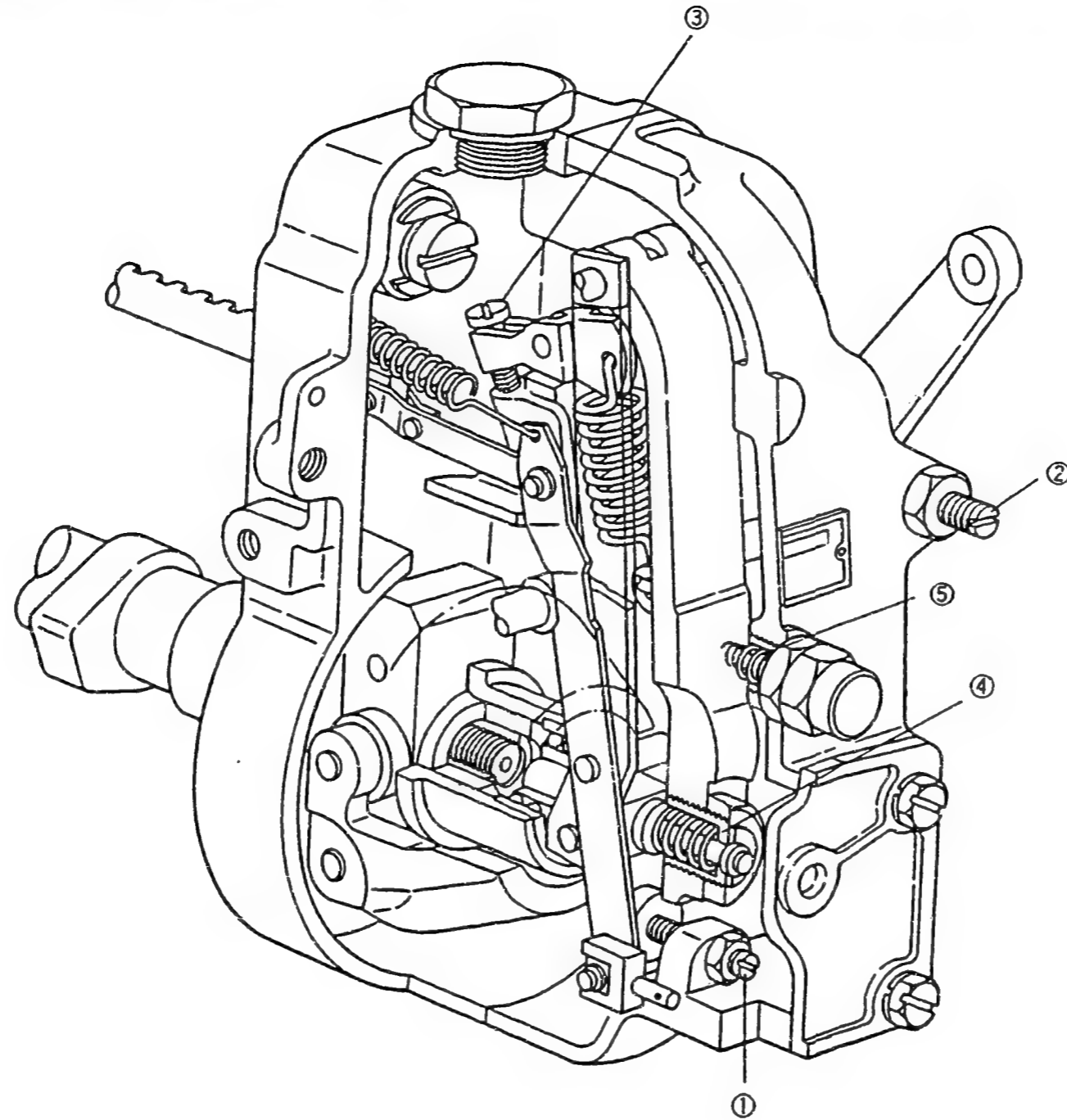

Figure 62

- 1 = Screw
- 2 = Screw
- 3 = Screw
- 4 = Spring capsule
- 5 = Spring capsule

101605-3561 4/4

L26

ZEXEL - Test values
Injection pumps



L27

ZEXEL - Test values
Injection pumps



ZEXEL - TEST VALUES
Injection pumps

BOSCH No.	:	9 400 610 215	1/4
ZEXEL No.	:	101605-3590	
Date	:	31.10.1992	[1]
Company	:	KOMATSU	
Engine	:	6D105 / 6136-72-1460	

IP-Type number : 101060-2470 / PE6A
Governor type number : 105410-6280 / EP/RSV

TEST PREREQUISITES

Test oil : ISO-4113
Test oil inlet temperature °C : 40.00...45.00
Inlet pressure bar : 1.6
Test nozzle holder combination : 1 688 901 013
Opening pressure bar : 175
Test pressure line
Inner x Outer Dia - Length mm : 2.00 x 6.00 x 600

PORT CLOSING

Prestroke mm : 3.3 ± 0.05
Rod position mm : -
Port closing mark Cyl. No. : -
Cam sequence : 1-5-3-6-2-4

Port closing mark Cyl. No. : -
Port closing difference °NW : 0-60-120-180-240-300

Tolerance +- °C: 0.50 (0.75)

M1

ZEXEL - Test values
Injection pumps



Continued (Test values)

Injection Quantity :

Adjusting Point	Rack Pos. (mm)	P. Speed (rpm)	Injection Q'ty (cm ³ /1000 str.)	Difference (%)	Fixed	Remarks
A	7.6	1750	31.9 ± 1.0	± 2.0	Rack	Basic
H	approx. 8.0	350	9.5 ± 1.0	± 10.0	Rack	
A	7.6	1750	31.9 ± 1.0	-	Lever	Basic

Timing Advance Specification :

Pump Speed (rpm)						
Advance Angle (deg)						

M2

ZEXEL - Test values
Injection pumps



M3

ZEXEL - Test values
Injection pumps



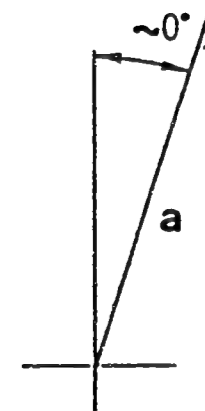
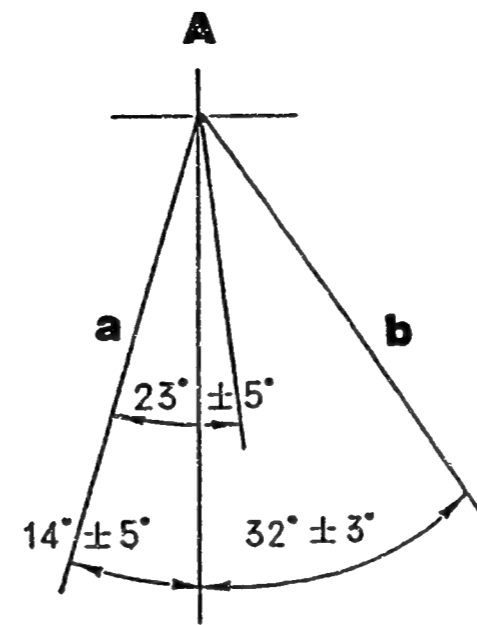
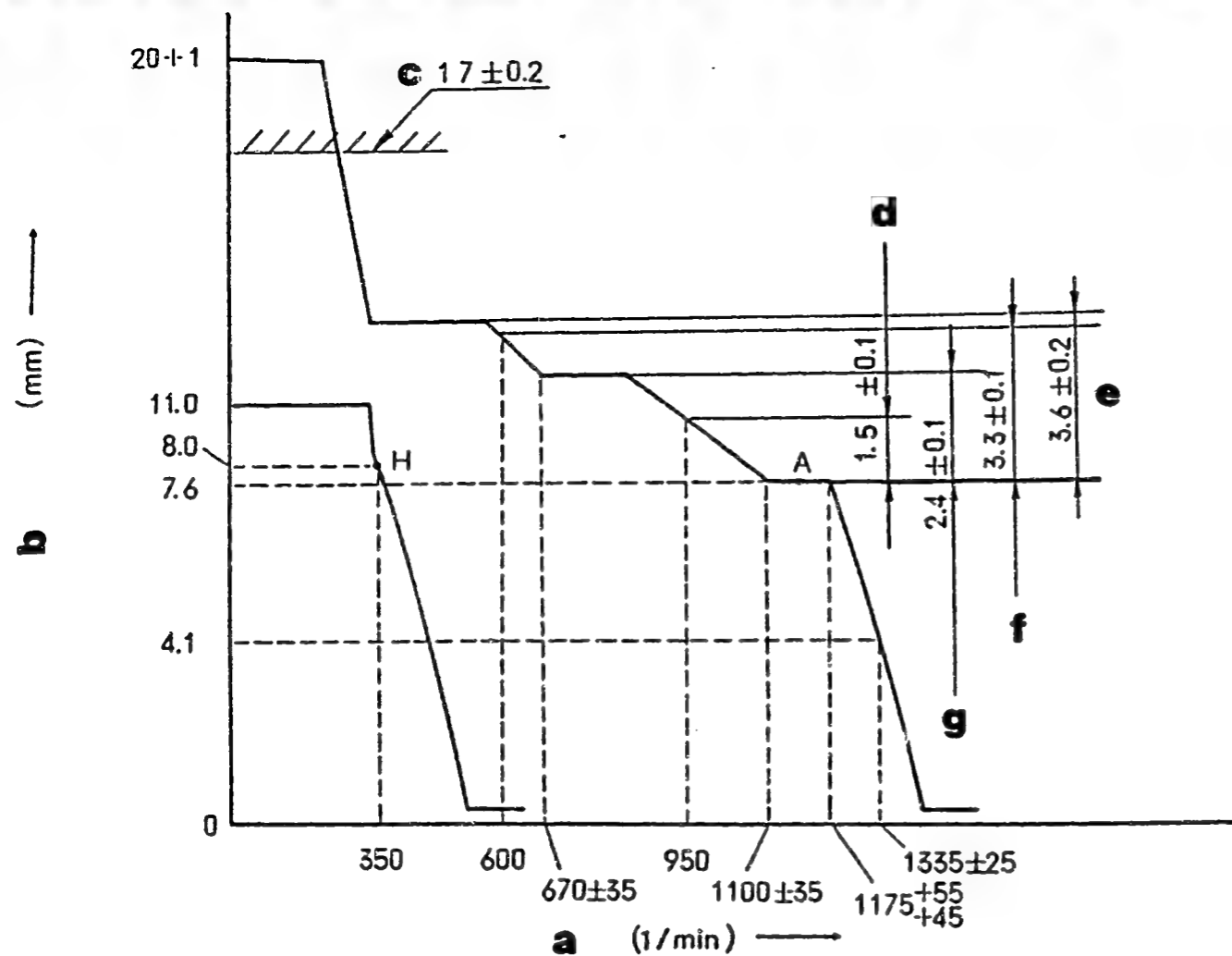

Figure 63

- a = Pump speed
- b = Control rack position
- c = Control rack limit:
- d = Difference in control rack position between 1175 rpm and 950 rpm
- e = Difference in control rack position between 1175 rpm and 550 rpm
- f = Difference in control rack position between 1175 rpm and 600 rpm
- g = Difference in control rack position between 1175 rpm and 750 rpm

GOVERNOR ADJUSTMENT

Recommended speed droop adjustment screw position: 14

101605-3590 2/4

A = Speed Control Lever Angle

- a = Full-speed
- b = Idling
- c = Stop

■ TIMING SETTING

At No. 1 plunger's beginning of injection position.

a = Camshaft key groove position

M4

ZEXEL - Test values
Injection pumps



M5

ZEXEL - Test values
Injection pumps



■ Note

- Before adjustment, remove the idling sub spring.
- Move the control lever fully in the stop direction, and set the minimum-speed stopper bolt so that the control rack position is 0.5 - 1.0 mm.

■ ADJUSTMENT

		Pump Speed (rpm)	Rack Position (mm)	Remarks
Full-load Adjustment (Temporary)		1375 600	7.6 7.6	<ul style="list-style-type: none"> • Adjust using screw (2) • Adjust using screw (1)
Torque Control Spring Adjustment	1st stroke	500 600 670 ± 35	11.2 10.9 10.0	<ul style="list-style-type: none"> • Adjust using spring capsule (4) • Confirm • Confirm the torque control stroke is 1.2 ± 0.1 mm
	2st stroke	720 950 1100 ± 35	10.0 9.1 7.6	<ul style="list-style-type: none"> • Adjust using spring capsule (4) • Confirm • Confirm the torque control stroke is 2.4 ± 0.1 mm
Idling Adjustment		0 350	11.0 8.0	<ul style="list-style-type: none"> • Fix the control lever • Adjust using spring capsule (5) • Confirm
Maximum Speed Adjustment		1175+55 +45 1335 ± 25	7.6 4.1	<ul style="list-style-type: none"> • Fix the control lever • Confirm speed droop - adjust using screw (3) • Confirm
Full-load Adjustment		1175	7.6	<ul style="list-style-type: none"> • Confirm
Control Lever Angle Measurement		<ul style="list-style-type: none"> • Measure the control lever angle at the "idling" and "full" positions. • When the control lever is depressed toward the "full" position, replace the shifter's shim with a thicker one. • When the control lever is depressed toward the "idling" position, replace the shifter's shim with a thinner one. 		
Rack Limiter Adjustment		-	-	<ul style="list-style-type: none"> • Adjust using screw

M6

ZEXEL - Test values
Injection pumps



M7

ZEXEL - Test values
Injection pumps



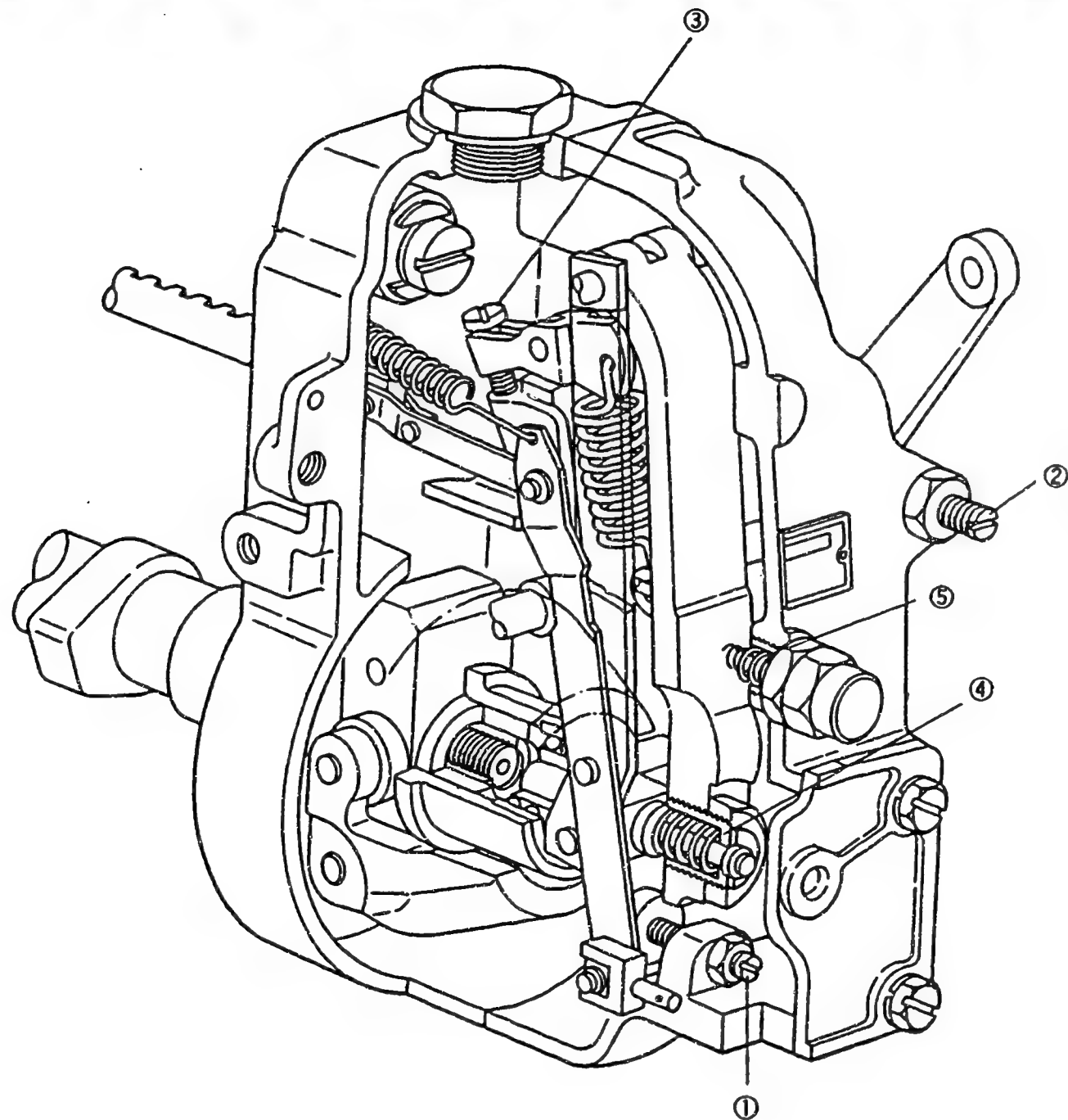

Figure 64

- 1 = Screw
- 2 = Screw
- 3 = Screw
- 4 = Spring capsule
- 5 = Spring capsule

101605-3590 4/4

M8

ZEXEL - Test values
Injection pumps



M9

ZEXEL - Test values
Injection pumps



ZEXEL - TEST VALUES
Injection pumps

BOSCH No.	:	9 400 610 216	1/4
ZEXEL No.	:	101692-3112	
Date	:	31.10.1992	[6]
Company	:	KOMATSU	
Engine	:	S6D95L / 6207-71-1320	
IP-Type number	:	101069-9210	/ PES6A
Governor type number	:	105400-3301	/ EP/RSV

TEST PREREQUISITES

Test oil	:	ISO-4113
Test oil inlet temperature °C	:	40.00...45.00
Inlet pressure bar	:	1.6
Test nozzle holder combination	:	1 688 901 013
Opening pressure bar	:	175
Test pressure line	:	
Inner x Outer Dia - Length mm	:	2.00 x 6.00 x 600

PORT CLOSING

Prestroke mm	:	3.6 ± 0.05
Rod position mm	:	-
Port closing mark Cyl. No.	:	-
Cam sequence	:	1-5-3-6-2-4
Port closing mark Cyl. No.	:	-
Port closing difference °NW	:	0-60-120-180-240-300
Tolerance +- °C	:	0.50 (0.75)

M10

ZEXEL - Test values
Injection pumps



Continued (Test values)

Injection Quantity :

Adjusting Point	Rack Pos. (mm)	P. Speed (rpm)	Injection Q'ty (cm ³ /1000 str.)	Difference (%)	Fixed	Remarks
A	10.8	1100	42.5 ± 1.0	± 2.5	Rack	Basic
	approx.10.4	425	12.5 ± 1.0	± 15.0	Rack	
A	10.8	1100	42.5 ± 1.0	-	Lever ‡	Basic

Timing Advance Specification :

Pump Speed (rpm)						
Advance Angle (deg)						

M11

ZEXEL - Test values
Injection pumps



M12

ZEXEL - Test values
Injection pumps



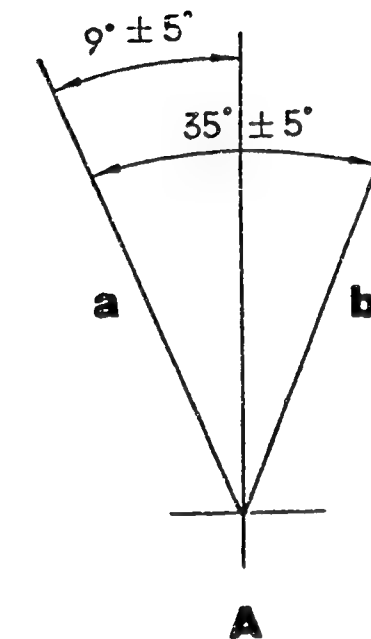
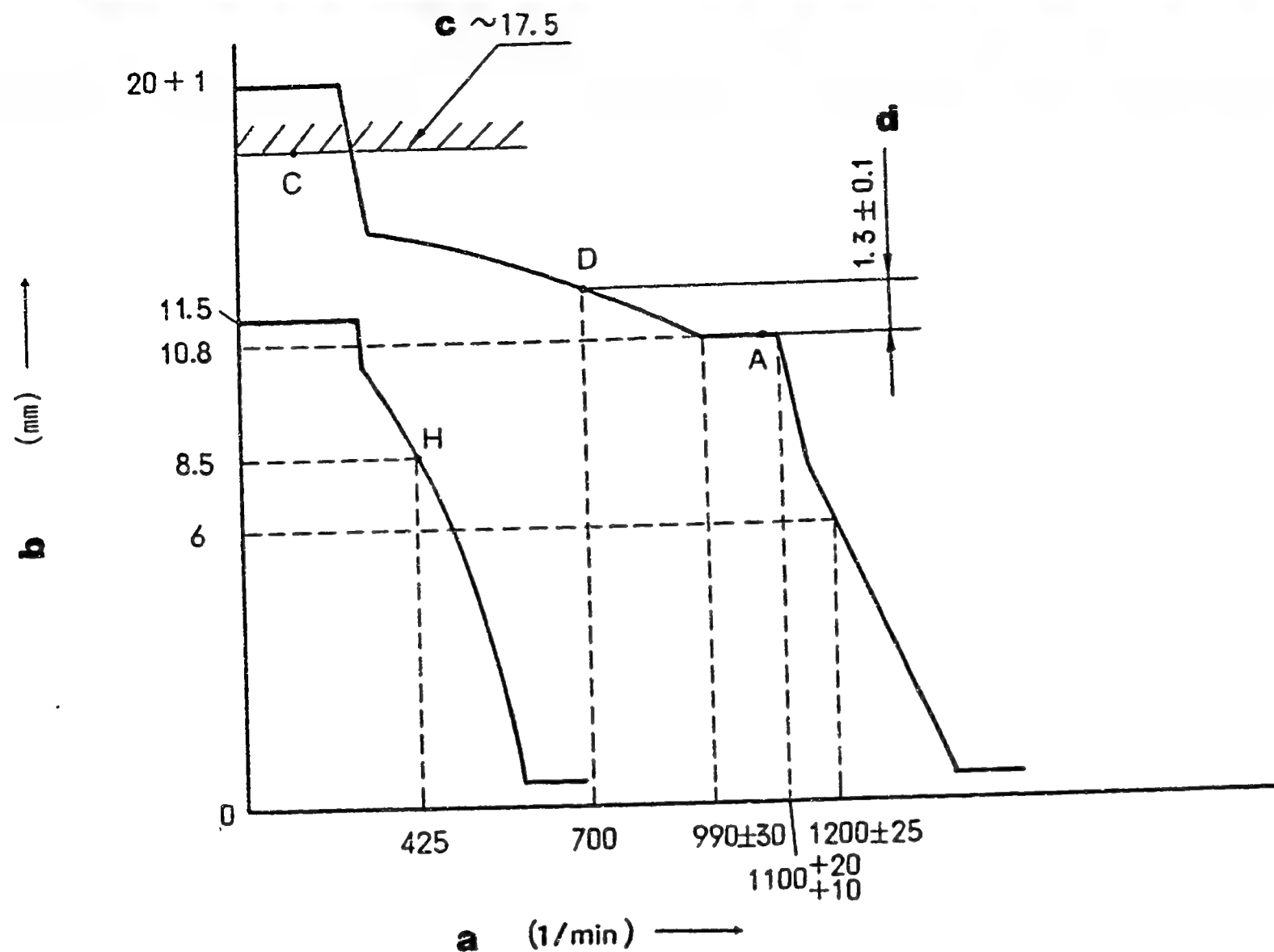

Figure 65

GOVERNOR ADJUSTMENT

101692-3112 2/4

Recommended speed droop adjustment screw position: 4

- a = Pump speed
- b = Control rack position
- c = Control rack limit:
- d = Difference in control rack position between 1100 rpm and 700 rpm

A = Speed Control Lever Angle

- a = Full-speed
- b = Idling

■ Note

- Before adjustment, remove the idling sub spring.
- Move the control lever fully in the stop direction, and set the minimum-speed stopper bolt so that the control rack position is 0.5 - 1.0 mm.

■ ADJUSTMENT

	Pump speed (rpm)	Rack position (mm)	Remarks
Full-load Adjustment (Temporary)	1300	10.8	<ul style="list-style-type: none"> • Adjust using screw (2) • Adjust using screw (1)
	600	10.8	
Torque Control spring Adjustment	700	12.1	<ul style="list-style-type: none"> • Adjust using spring capsule (4) • Confirm • Confirm the torque control stroke is: 1.3 ± 0.1 mm
	990 ± 30	10.8	
Idling Adjustment	0	11.5	<ul style="list-style-type: none"> • Fix the control lever • Adjust using spring capsule (5) • Confirm
	425	8.5	
Maximum-speed Adjustment	1100 ± 20	10.8	<ul style="list-style-type: none"> • Fix the control lever • Confirm speed droop - adjust using screw (3) • Confirm
	1200 ± 25 +10	6.0	
Full-load Adjustment	1100	10.8	<ul style="list-style-type: none"> • Confirm
Control Lever Angle Measurement	<ul style="list-style-type: none"> • Measure the control lever angle at the "idling" and "full" positions. • When the control lever is depressed toward the "full" position, replace the shifter's shim with a thicker one. • When the control lever is depressed toward the "idling" position, replace the shifter's shim with a thinner one. 		
Rack Limiter Adjustment	0	17.5	<ul style="list-style-type: none"> • Adjust using screw

M15

ZEXEL - Test values
Injection pumps



M16

ZEXEL - Test values
Injection pumps



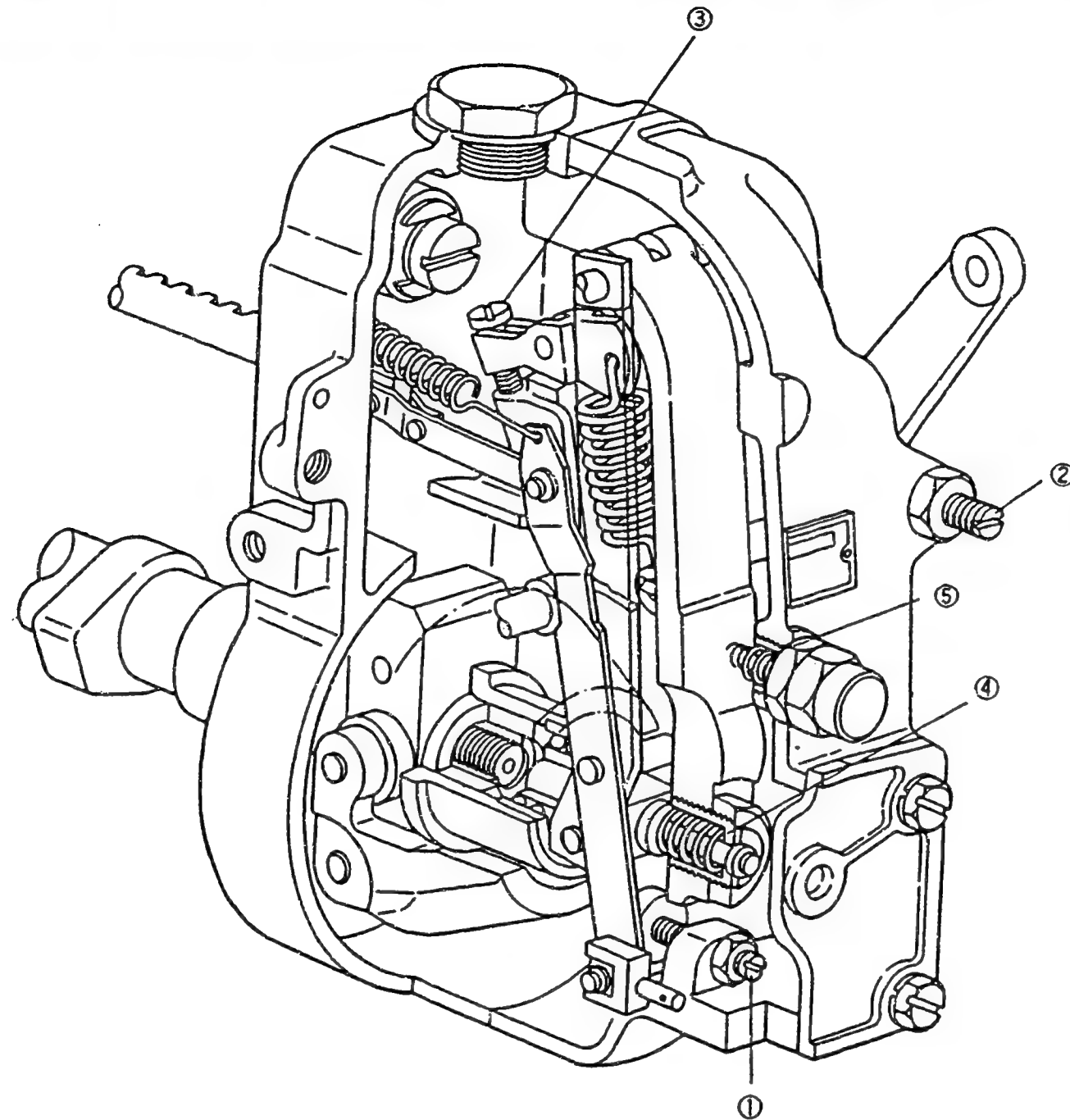

Figure 66

- 1 = Screw
- 2 = Screw
- 3 = Screw
- 4 = Spring capsule
- 5 = Spring capsule



ZEXEL - TEST VALUES
Injection pumps

BOSCH No.	:	9 400 610 217	1/4
ZEXEL No.	:	101692-3161	
Date	:	31.10.1992	[1]
Company	:	KOMATSU	
Engine	:	6D95L / 6206-71-1420	

IP-Type number : 101069-9141 / PES6A
Governor type number : 105400-3550 / EP/RSV

TEST PREREQUISITES

Test oil : ISO-4113
Test oil inlet temperature °C : 40.00...45.00
Inlet pressure bar : 1.6
Test nozzle holder combination : 1 688 901 013
Opening pressure bar : 175
Test pressure line
Inner x Outer Dia - Length mm : 2.00 x 6.00 x 600

PORT CLOSING

Prestroke mm : 3.6 ± 0.05
Rod position mm : -
Port closing mark Cyl. No. : -
Cam sequence : 1-5-3-6-2-4

Port closing mark Cyl. No. : -
Port closing difference °NW : 0-60-120-180-240-300

Tolerance +- °C: 0.50 (0.75)

M19

ZEXEL - Test values
Injection pumps



Injection Quantity :

Adjusting Point	Rack Pos. (mm)	P. Speed (rpm)	Injection Q'ty (cm ³ /1000 str.)	Difference (%)	Fixed	Remarks
A	10.3	900	52.0 ± 1.0	± 2.5	Rack	Basic
H	approx. 8.0	400	10.5 ± 1.0	± 15.0	Rack	
A	10.3	900	52.0 ± 1.0	-	Lever	Basic

Timing Advance Specification :

Pump Speed (rpm)					
Advance Angle (deg)					

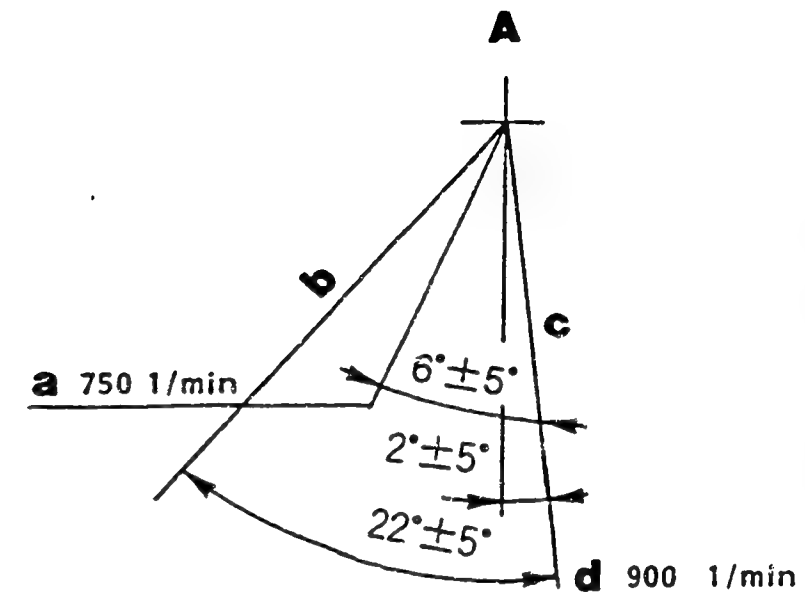
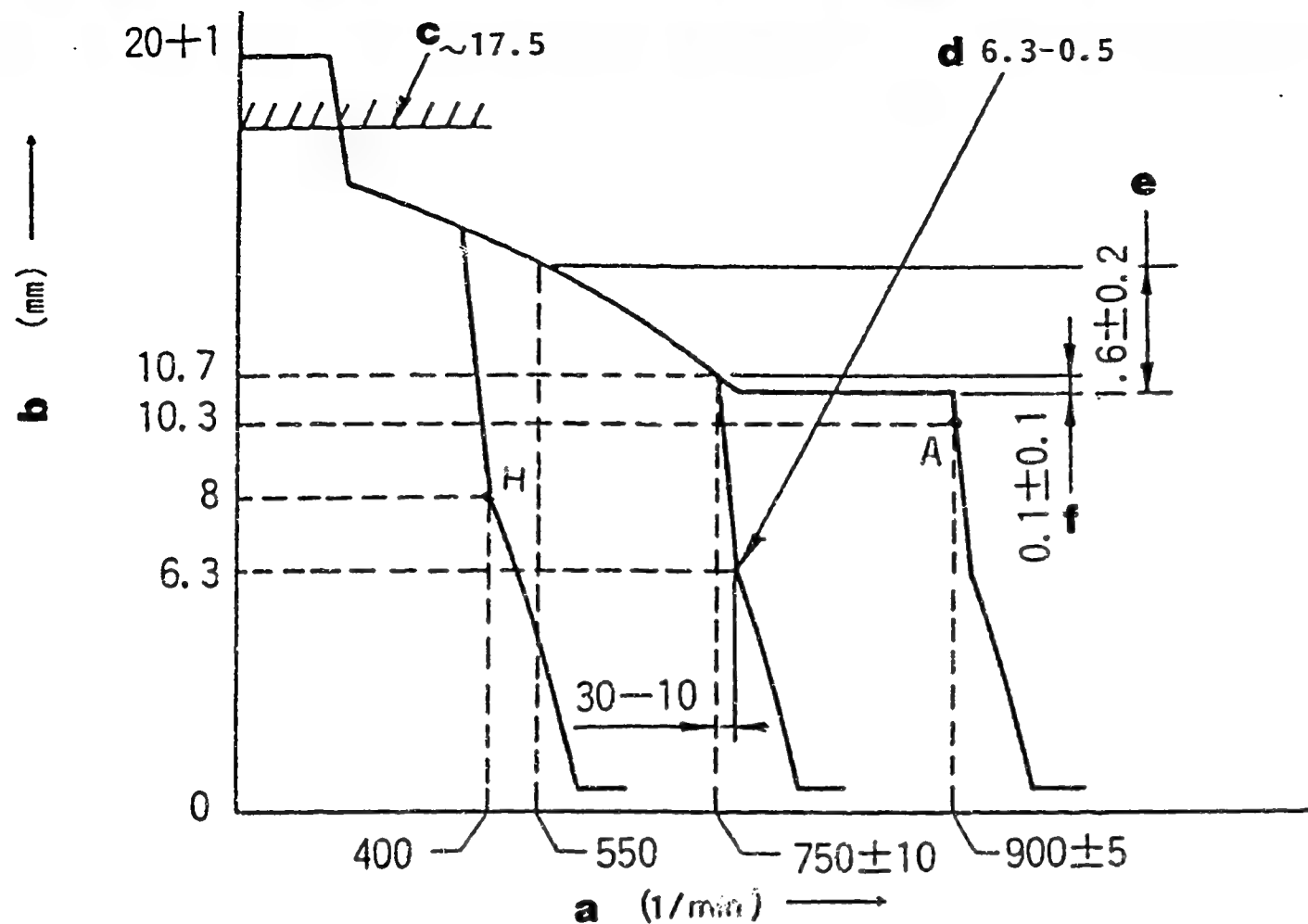

Figure 67

GOVERNOR ADJUSTMENT

101692-3161 2/4

Recommended speed droop adjustment screw position: 12

- a = Pump speed
- b = Control rack position
- c = Control rack limit:
- d = Idle-sub spring setting:
- e = Difference in control rack position at 800 rpm
- f = Difference in control rack position between 800 rpm and 750 rpm

A = Speed Control Lever Angle

- a = Setting:
- b = Idling
- c = Full-speed
- b = Setting:
(On our shipment)

M 22

ZEXEL - Test values
Injection pumps



M 23

ZEXEL - Test values
Injection pumps



■ Note

- Before adjustment, remove the idling sub spring.
- Move the control lever fully in the stop direction, and set the minimum-speed stopper bolt so that the control rack position is 0.5 - 1.0 mm.

■ ADJUSTMENT

		Pump Speed (rpm)	Rack Position (mm)	Boost pressure kPa (mmHg)	Remarks
Full-load Adjustment (Temporary)		1100 600	10.7 10.7	-	<ul style="list-style-type: none"> • Adjust using screw (2) • Adjust using screw (1)
Torque Control Spring Adjust- ment	1.st stroke	550 750 ± 10	12.3 10.7	-	<ul style="list-style-type: none"> • Adjust using spring capsule (4) • Confirm • Confirm the torque control stroke is: 1.6 ± 0.1 mm
	2.st stroke	-	-	-	<ul style="list-style-type: none"> • Adjust using spring capsule (4) • Confirm • Confirm the torque control stroke is: (mm)
Maximum-speed Adjustment		750 ± 10 750+30 +20 900 ± 5	10.7 6.3 10.3	-	<ul style="list-style-type: none"> • Fix the control lever • Confirm speed droop - adjust using screw (3) • Confirm
Boost Compensator System		-	-	-	<ul style="list-style-type: none"> • Fix the control lever • Adjust using screw (6) • Confirm the boost compensator stroke is: (mm)
Idling Adjustment		750+30 +20	6.3	-	<ul style="list-style-type: none"> • Fix the control lever • Adjust using spring capsule (5) • Confirm
1. Idling Sub Spring					
2. Control Lever	H	400	8.0	-	<ul style="list-style-type: none"> • Adjust using the control lever
Full-load Adjustment		800	10.6	-	<ul style="list-style-type: none"> • Adjust using screw (1)
Control Lever Angle Measurement		<ul style="list-style-type: none"> • Measure the control lever angle at the "idling" and "full" positions. • When the control lever is depressed toward the "full" position, replace the shifter's shim with a thicker one. • When the control lever is depressed toward the "idling" position, replace the shifter's shim with a thinner one. 			
Control Rack Limiter Adjustment		0	approx. 17.5	-	<ul style="list-style-type: none"> • Adjust using screw

M 24

ZEXEL - Test values
Injection pumps



M 25

ZEXEL - Test values
Injection pumps



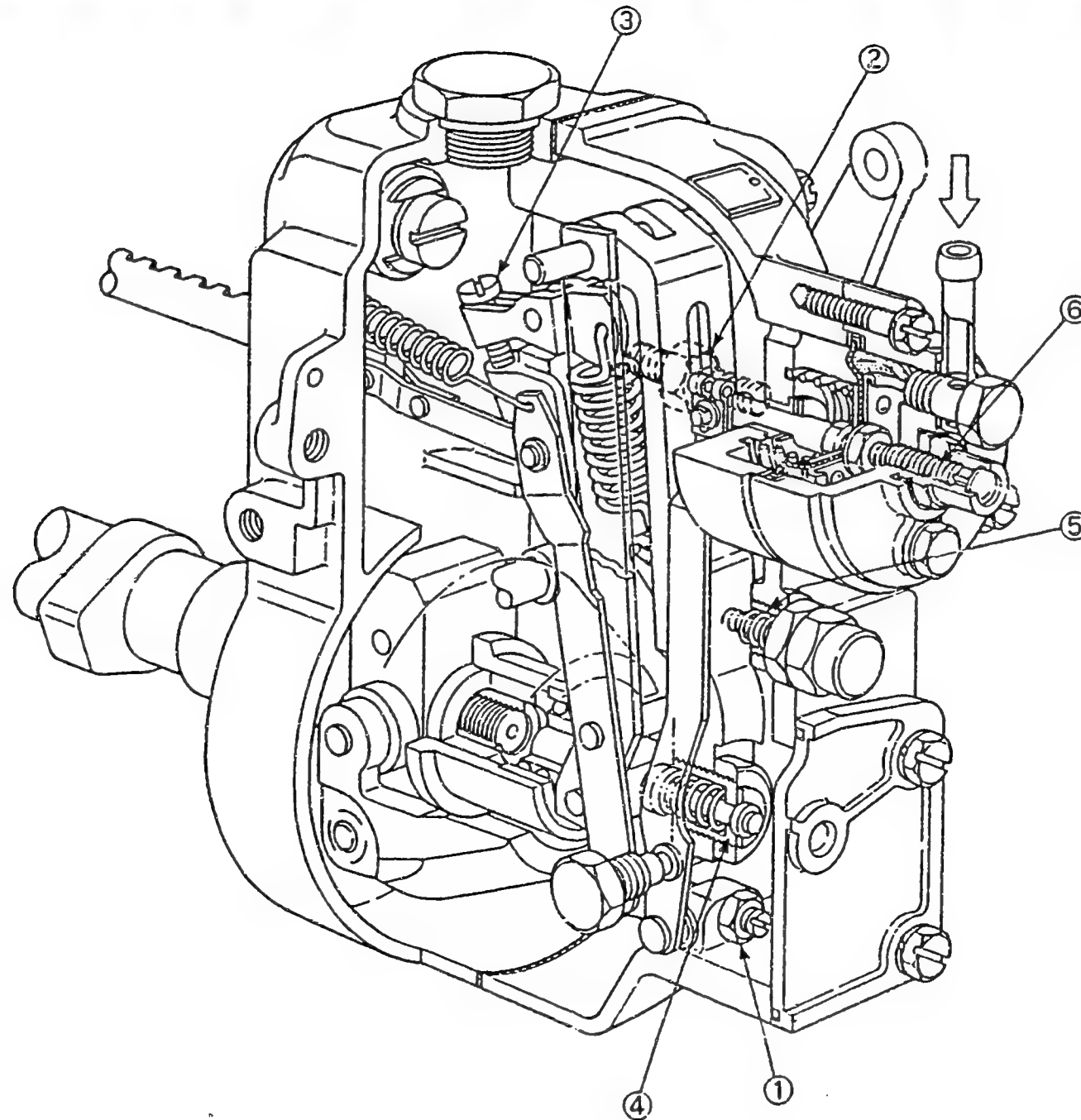

Figure 68

- 1 = Screw
- 2 = Screw
- 3 = Screw
- 4 = Spring capsule
- 5 = Spring capsule
- 6 = Screw

101692-3161 4/4

M 26

ZEXEL - Test values
Injection pumps



M 27

ZEXEL - Test values
Injection pumps



ZEXEL - TEST VALUES
Injection pumps

BOSCH No.	:	9 400 610 218	1/4
ZEXEL No.	:	101692-3430	
Date	:	31.10.1992	[2]
Company	:	KOMATSU	
Engine	:	S6D95L / 6207-71-1360	

IP-Type number : 101069-9210 / PES6A
Governor type number : 105400-4550 / EP/RSV

TEST PREREQUISITES

Test oil : ISO-4113
Test oil inlet temperature °C : 40.00...45.00
Inlet pressure bar : 1.6
Test nozzle holder combination : 1 688 901 013
Opening pressure bar : 175
Test pressure line
Inner x Outer Dia - Length mm : 2.00 x 6.00 x 600

PORT CLOSING

Prestroke mm : 3.6 ± 0.05
Rod position mm : -
Port closing mark Cyl. No. : -
Cam sequence : 1-5-3-6-2-4

Port closing mark Cyl. No. : -
Port closing difference °NW : 0-60-120-180-240-300

Tolerance +- °C: 0.50 (0.75)

N1

ZEXEL - Test values
Injection pumps



Injection Quantity :

Adjusting Point	Rack Pos. (mm)	P. Speed (rpm)	Injection Q'ty (cm ³ /1000 str.)	Difference (%)	Fixed	Remarks
A	11.1	1100	45.1 ± 1.0	± 2.5	Rack	Basic
	approx.10.4	425	12.5 ± 1.0	± 15.0	Rack	
A	11.1	1100	45.1 ± 1.0	± 2.5	Lever	Basic

Timing Advance Specification :

Pump Speed (rpm)						
Advance Angle (deg)						

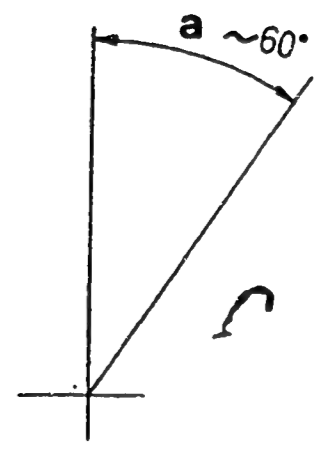
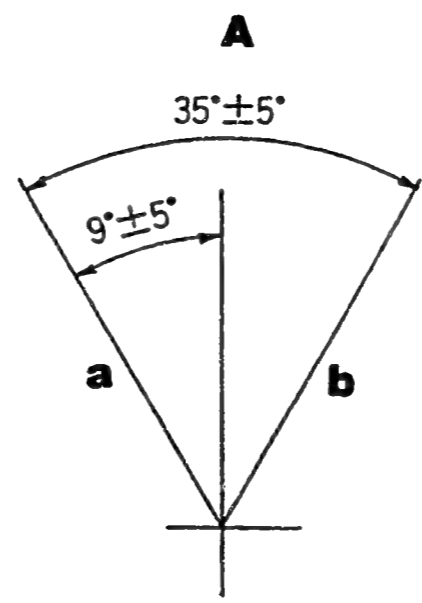
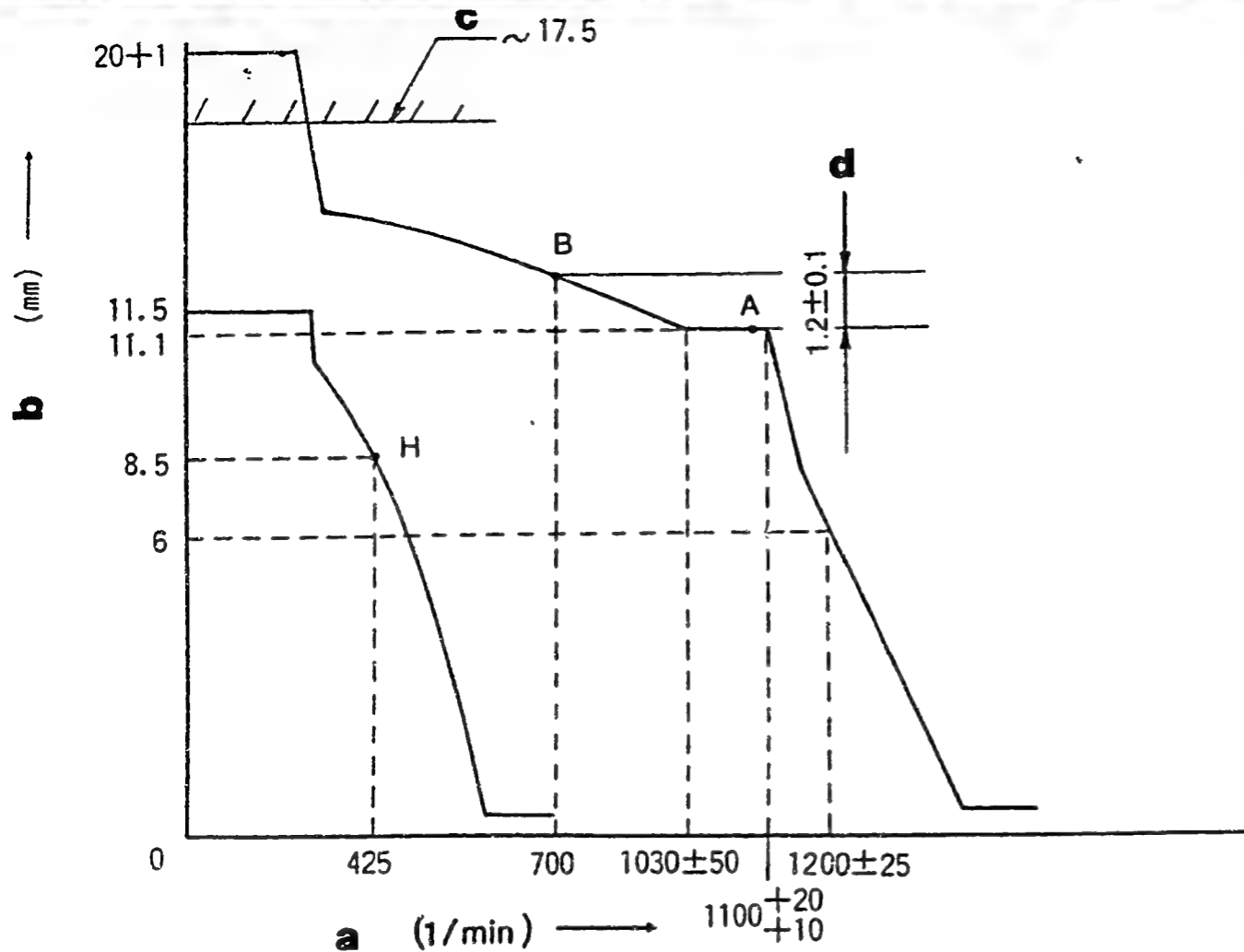

Figure 69

GOVERNOR ADJUSTMENT

101692-3430 2/4

Recommended speed droop adjustment screw position: 4

- a = Pump speed
- b = Control rack position
- c = Control rack limit:
- d = Difference in control rack position between 1100 rpm and 700 rpm

A = Speed Control Lever Angle

- a = Full-speed
- b = Idling

■ TIMING SETTING

At No. 1 plunger's beginning of injection position.

a = Camshaft key groove position

■ Note

- Before adjustment, remove the idling sub spring.
- Move the control lever fully in the stop direction, and set the minimum-speed stopper bolt so that the control rack position is 0.5 - 1.0 mm.

■ ADJUSTMENT

	Pump speed (rpm)	Rack position (mm)	Remarks
Full-load Adjustment (Temporary)	1300 600	11.1 11.1	<ul style="list-style-type: none"> • Adjust using screw (2) • Adjust using screw (1)
Torque Control spring Adjustment	700 1030 ± 50	12.3 11.1	<ul style="list-style-type: none"> • Adjust using spring capsule (4) • Confirm • Confirm the torque control stroke is: 1.2 ± 0.1 mm
Idling Adjustment	0 425	11.5 8.5	<ul style="list-style-type: none"> • Fix the control lever • Adjust using spring capsule (5) • Confirm
Maximum-speed Adjustment	1100+20 +10 1200 ± 25	11.1 6.0	<ul style="list-style-type: none"> • Fix the control lever • Confirm speed droop - adjust using screw (3) • Confirm
Full-load Adjustment	1100	11.1	<ul style="list-style-type: none"> • Confirm
Control Lever Angle Measurement	<ul style="list-style-type: none"> • Measure the control lever angle at the "idling" and "full" positions. • When the control lever is depressed toward the "full" position, replace the shifter's shim with a thicker one. • When the control lever is depressed toward the "idling" position, replace the shifter's shim with a thinner one. 		
Rack Limiter Adjustment	0	17.5	<ul style="list-style-type: none"> • Adjust using screw

N6

ZEXEL - Test values
Injection pumps



N7

ZEXEL - Test values
Injection pumps



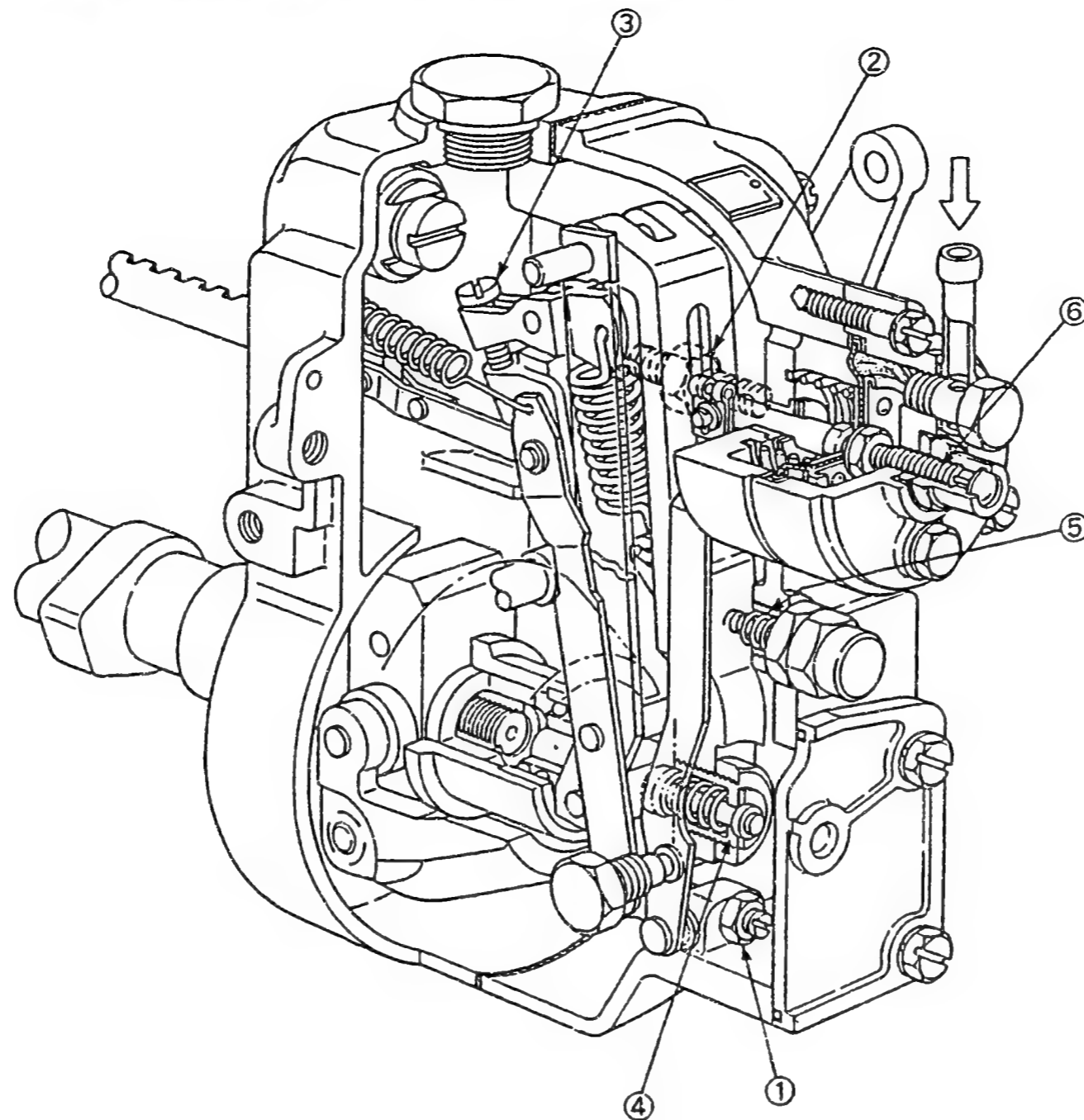

Figure 70

- 1 = Screw
- 2 = Screw
- 3 = Screw
- 4 = Spring capsule
- 5 = Spring capsule
- 6 = Screw

N8

ZEXEL - Test values
Injection pumps



N9

ZEXEL - Test values
Injection pumps



ZEXEL - TEST VALUES
Injection pumps

BOSCH No.	:	9 400 610 219	1/4
ZEXEL No.	:	101692-3451	
Date	:	31.10.1992	[2]
Company	:	KOMATSU	
Engine	:	6D95L / 6206-71-1360	

IP-Type number : 101069-9180 / PES6A
Governor type number : 105400-4601 / EF/RSV

TEST PREREQUISITES

Test oil : ISO-4113
Test oil inlet temperature °C : 40.00...45.00
Inlet pressure bar : 1.6
Test nozzle holder combination : 1 688 901 013
Opening pressure bar : 175
Test pressure line
Inner x Outer Dia - Length mm : 2.00 x 6.00 x 600

PORT CLOSING

Prestroke mm : 3.6 ± 0.05
Rod position mm : -
Port closing mark Cyl. No. : -
Cam sequence : 1-5-3-6-2-4

Port closing mark Cyl. No. : -
Port closing difference °NW : 0-60-120-180-240-300

Tolerance +- °C: 0.50 (0.75)

N10

ZEXEL - Test values
Injection pumps



Injection Quantity :

Adjusting Point	Rack Pos. (mm)	P. Speed (rpm)	Injection Q'ty (cm ³ /1000 str.)	Difference (%)	Fixed	Remarks
A	9.9	1250	31.6 ± 1.0	± 2.5	Rack	Basic
	approx. 10.5	400	10.5 ± 1.0	± 15.0	Rack	
A	9.9	1250	31.6 ± 1.0	-	Lever	Basic
B	11.2	800	(37.9 ± 2.0)	-	Lever	

Timing Advance Specification :

Pump Speed (rpm)						
Advance Angle (deg)						

N11

ZEXEL - Test values
Injection pumps



N12

ZEXEL - Test values
Injection pumps



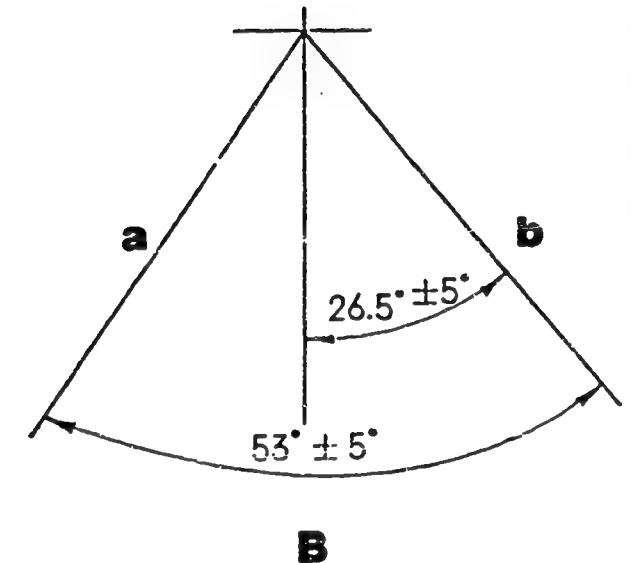
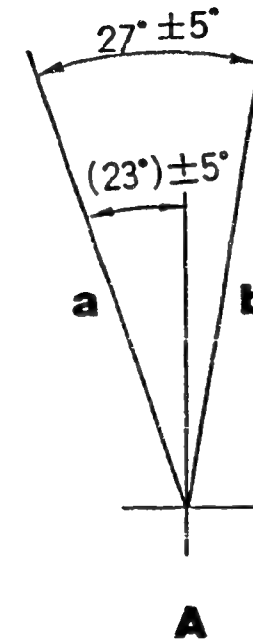
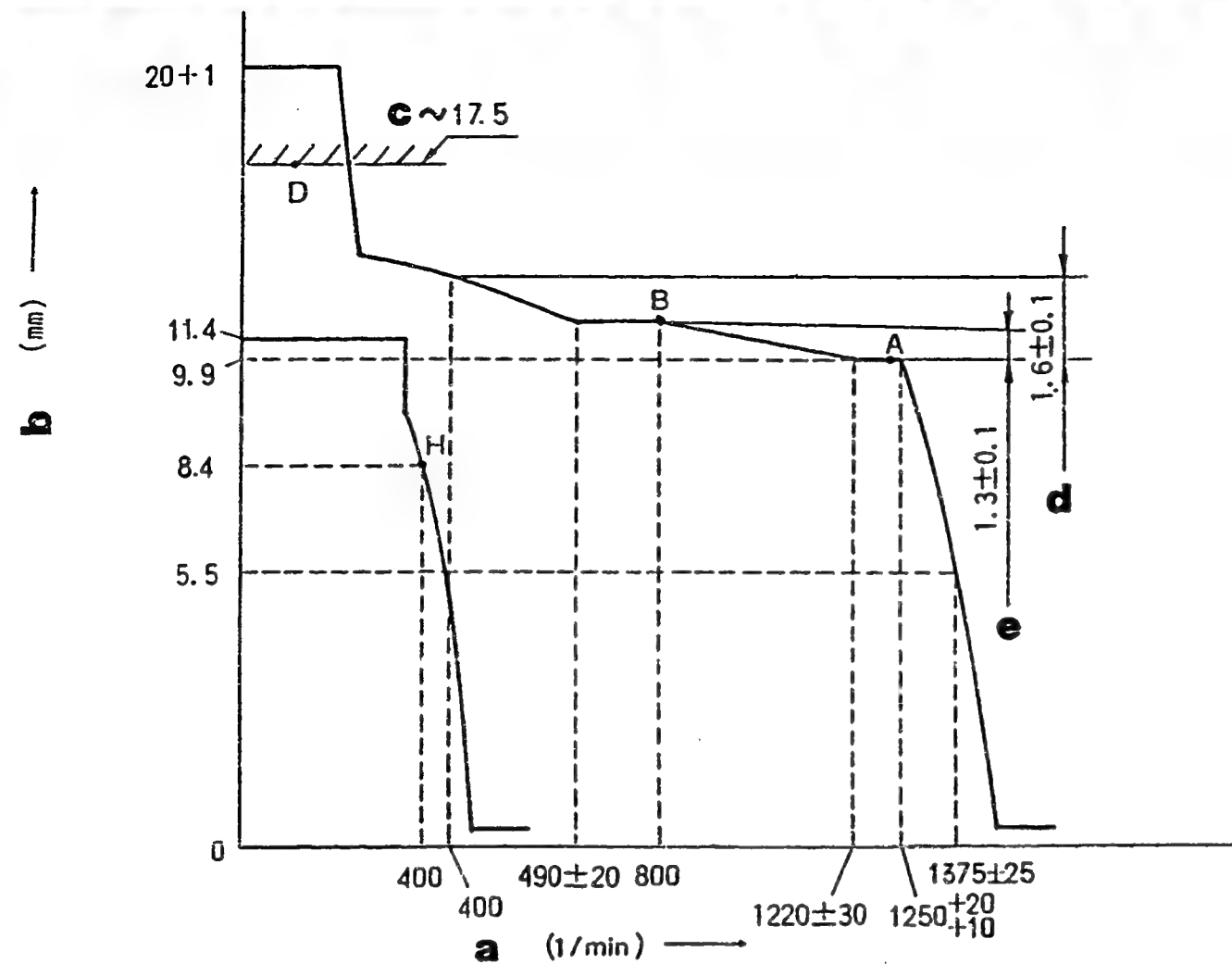

Figure 71

GOVERNOR ADJUSTMENT

101692-3451 2/4

Recommended speed droop adjustment screw position: 16

- a = Pump speed
- b = Control rack position
- c = Control rack limit:
- d = Difference in control rack position between 1250 rpm and 400 rpm
- e = Difference in control rack position between 1250 rpm and 800 rpm

A = Speed Control Lever Angle

A = STOP LEVER ANGLE

a = Full-speed

a = Stop

b = Idling

b = Normal

N13

ZEXEL - Test values
Injection pumps



N14

ZEXEL - Test values
Injection pumps



■ Note

- Before adjustment, remove the idling sub spring.
- Move the control lever fully in the stop direction, and set the minimum-speed stopper bolt so that the control rack position is 0.5 - 1.0 mm.

■ ADJUSTMENT

	Pump Speed (rpm)	Rack Position (mm)	Remarks
Full-load Adjustment (Temporary)	1450 600	9.9 9.9	<ul style="list-style-type: none"> • Adjust using screw (2) • Adjust using screw (1)
Torque Control Spring Adjustment	400 490 ± 20	11.5 11.2	<ul style="list-style-type: none"> • Adjust using spring capsule (4) • Confirm • Confirm the torque control stroke is 0.3 ± 0.1 mm
	700 800 1220 ± 30	11.2 11.2 9.9	<ul style="list-style-type: none"> • Adjust using spring capsule (4) • Confirm • Confirm the torque control stroke is 1.3 ± 0.1 mm
Idling Adjustment	0 400	11.4 8.4	<ul style="list-style-type: none"> • Fix the control lever • Adjust using spring capsule (5) • Confirm
	1250+20 +10 1375 ± 25	9.9 5.5	<ul style="list-style-type: none"> • Fix the control lever • Confirm speed droop - adjust using screw (3) • Confirm
Full-load Adjustment	1250	9.9	<ul style="list-style-type: none"> • Confirm
Control Lever Angle Measurement	<ul style="list-style-type: none"> • Measure the control lever angle at the "idling" and "full" positions. • When the control lever is depressed toward the "full" position, replace the shifter's shim with a thicker one. • When the control lever is depressed toward the "idling" position, replace the shifter's shim with a thinner one. 		
Rack Limiter Adjustment	0	approx. 17.5	<ul style="list-style-type: none"> • Adjust using screw

N15

ZEXEL - Test values
Injection pumps



N16

ZEXEL - Test values
Injection pumps



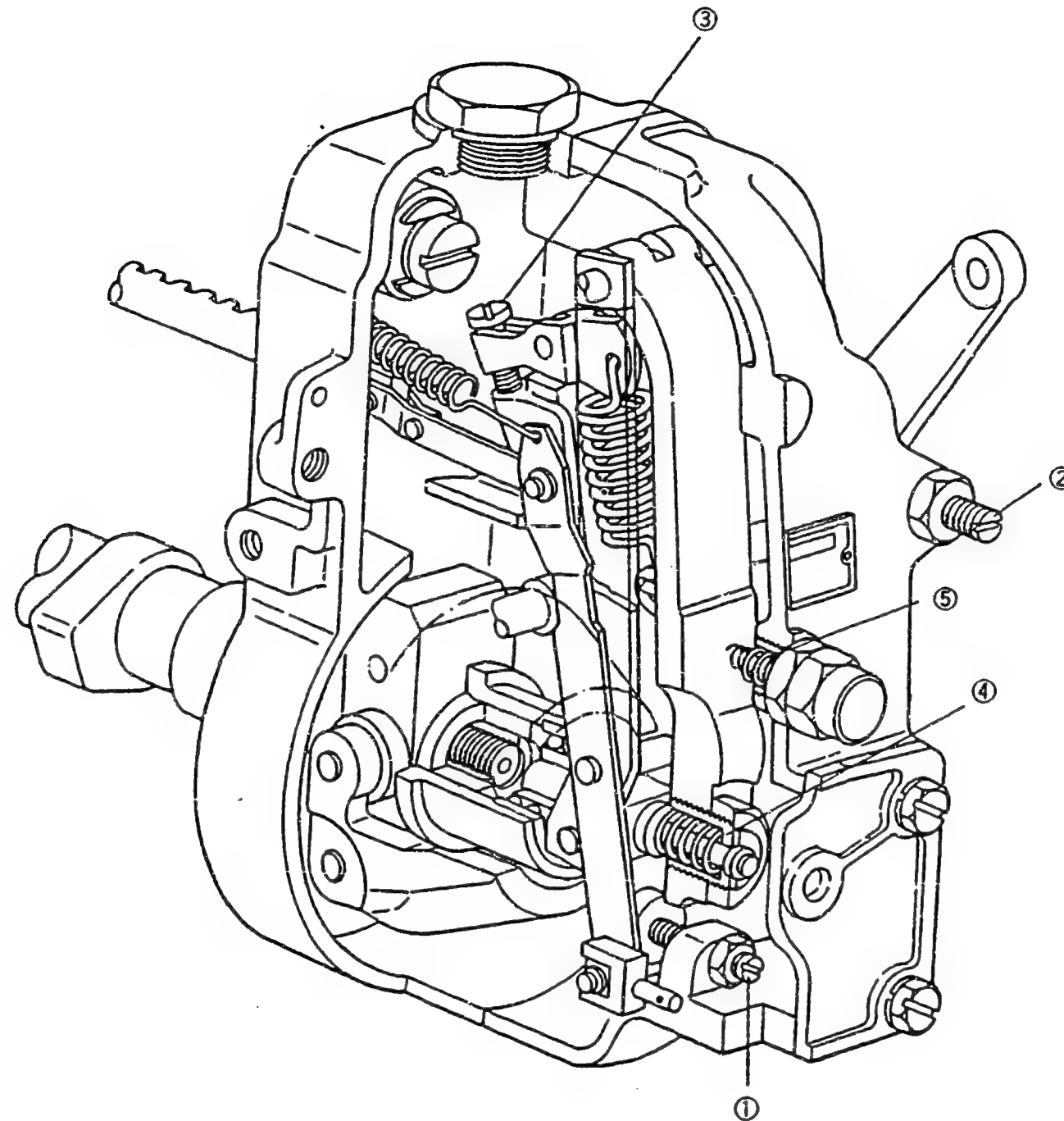

Figure 72

- 1 = Screw
- 2 = Screw
- 3 = Screw
- 4 = Spring capsule
- 5 = Spring capsule

101692-3451 4/4

N17

ZEXEL - Test values
Injection pumps



N18

ZEXEL - Test values
Injection pumps



ZEXEL - TEST VALUES
Injection pumps

BOSCH No.	:	9 400 610 220	1/4
ZEXEL No.	:	101692-3461	
Date	:	31.10.1992	[3]
Company	:	KOMATSU	
Engine	:	S6D95L / 6207-71-1380	

IP-Type number : 101069-9210 / PES6A
Governor type number : 105400-4610 / EP/RSV

TEST PREREQUISITES

Test oil : ISO-4113
Test oil inlet temperature °C : 40.00...45.00
Inlet pressure bar : 1.6
Test nozzle holder combination : 1 688 901 013
Opening pressure bar : 175
Test pressure line
Inner x Outer Dia - Length mm : 2.00 x 6.00 x 600

PORT CLOSING

Prestroke mm : 3.6 ± 0.05
Rod position mm : -
Port closing mark Cyl. No. : -
Cam sequence : 1-5-3-6-2-4

Port closing mark Cyl. No. : -
Port closing difference °NW : 0-60-120-180-240-300

Tolerance +- °C: 0.50 (0.75)

N19

ZEXEL - Test values
Injection pumps



Injection Quantity :

Adjusting Point	Rack Pos. (mm)	P. Speed (rpm)	Injection Q'ty (cm ³ /1000 str.)	Difference (%)	Fixed	Remarks
A	10.6	1250	40.4 ± 1.0	± 2.5	Rack	Basic
	approx.10.5	400	12.5 ± 1.0	± 15.0	Rack	
A	10.6	1250	40.4 ± 1.0	-	Lever	Basic

Timing Advance Specification :

Pump Speed (rpm)						
Advance Angle (deg)						

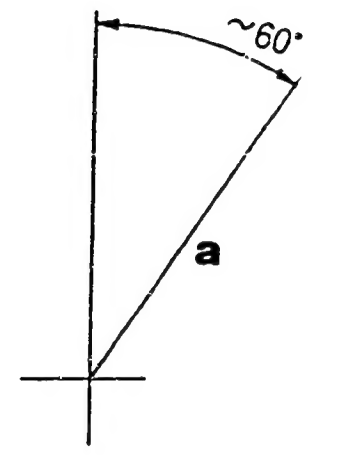
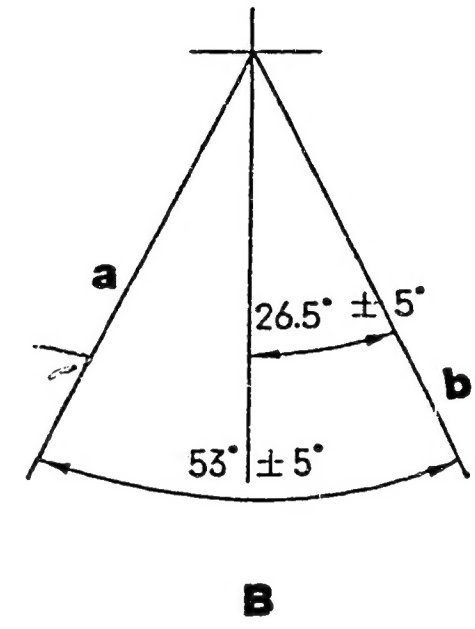
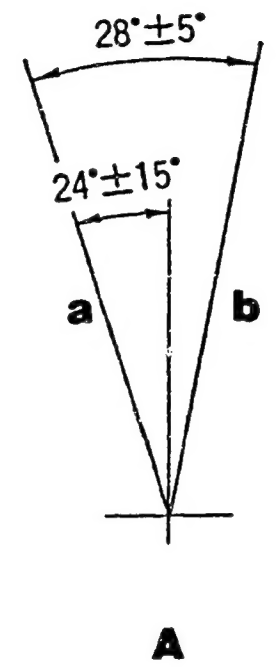
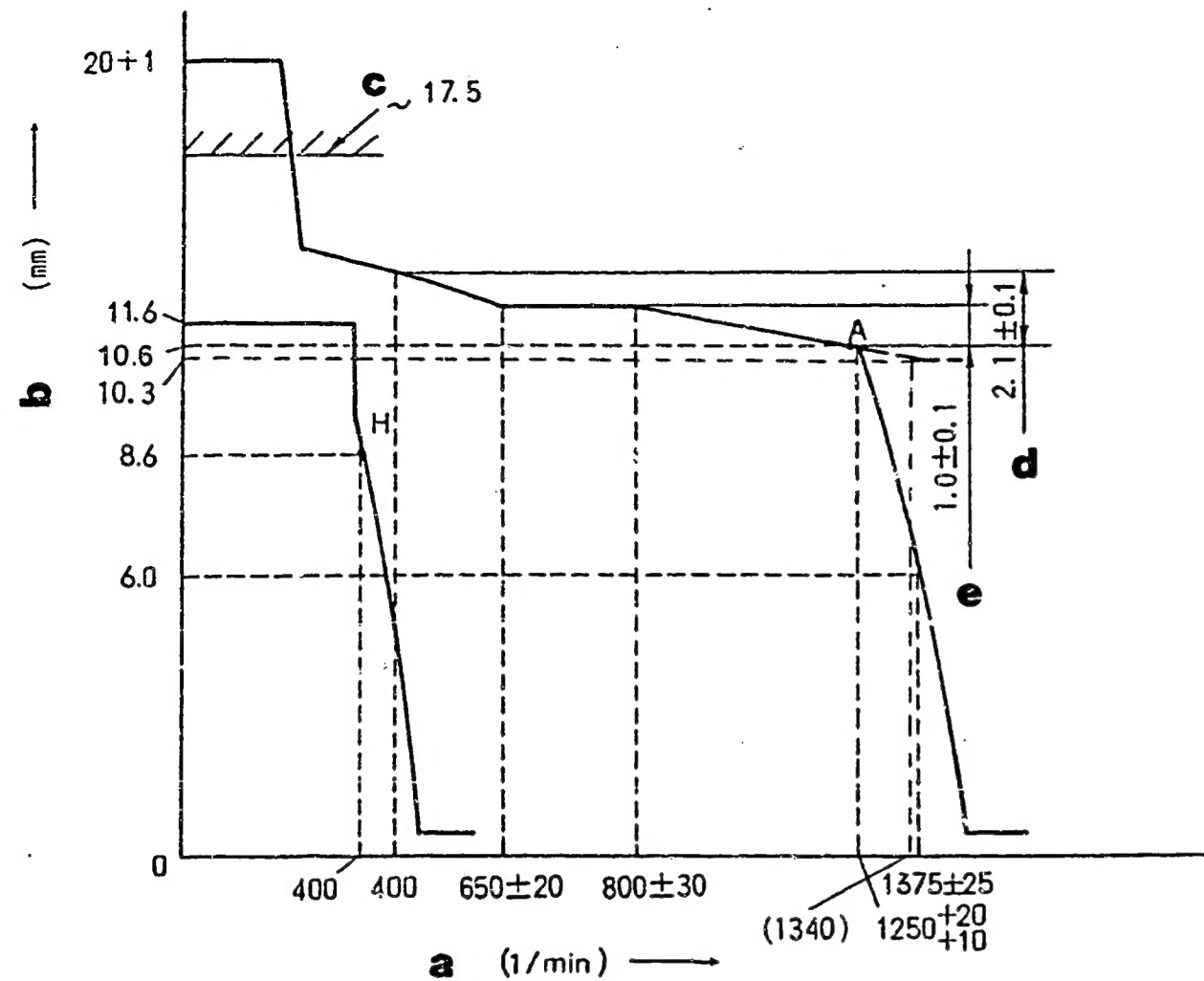

Figure 73

GOVERNOR ADJUSTMENT

101692-3461 2/4

Recommended speed droop adjustment screw position: 16

- a = Pump speed
- b = Control rack position
- c = Control rack limit:
- d = Difference in control rack position between 1250 rpm and 400 rpm
- e = Difference in control rack position between 1250 rpm and 750 rpm

- A = Speed Control Lever Angle**
- a = Full-speed
- b = Idling
- B = STOP LEVER ANGLE**
- a = Stop
- b = Normal

■ TIMING SETTING

At No.1 plunger's beginning of injection position.

a = Camshaft key groove position

■ Note

- Before adjustment, remove the idling sub spring.
- Move the control lever fully in the stop direction, and set the minimum-speed stopper bolt so that the control rack position is 0.5 - 1.0 mm.

■ ADJUSTMENT

	Pump Speed (rpm)	Rack Position (mm)	Remarks
Full-load Adjustment (Temporary)	1450 600	10.6 10.6	<ul style="list-style-type: none"> • Adjust using screw (2) • Adjust using screw (1)
Torque Control Spring Adjustment	400	12.7	<ul style="list-style-type: none"> • Adjust using spring capsule (4) • Confirm • Confirm the torque control stroke is 1.1 ± 0.1 mm
	650 ± 20	11.6	
2st stroke	700	11.6	<ul style="list-style-type: none"> • Adjust using spring capsule (4) • Confirm • Confirm the torque control stroke is 1.0 ± 0.1 mm • Confirm
	800 ± 30	11.6	
	1250+20	10.6	
	+10 approx. 1340	10.3	
Idling Adjustment	0	11.6	<ul style="list-style-type: none"> • Fix the control lever • Adjust using spring capsule (5) • Confirm
	400	8.6	
Maximum Speed Adjustment	1250+20	10.6	<ul style="list-style-type: none"> • Fix the control lever • Confirm speed droop - adjust using screw (3) • Confirm
	+10 1375 ± 25	6.0	
Full-load Adjustment	1250	10.6	<ul style="list-style-type: none"> • Confirm
Control Lever Angle Measurement	<ul style="list-style-type: none"> • Measure the control lever angle at the "idling" and "full" positions. • When the control lever is depressed toward the "full" position, replace the shifter's shim with a thicker one. • When the control lever is depressed toward the "idling" position, replace the shifter's shim with a thinner one. 		
Rack Limiter Adjustment	0	approx. 17.5	<ul style="list-style-type: none"> • Adjust using screw

N24

ZEXEL - Test values
Injection pumps



N25

ZEXEL - Test values
Injection pumps



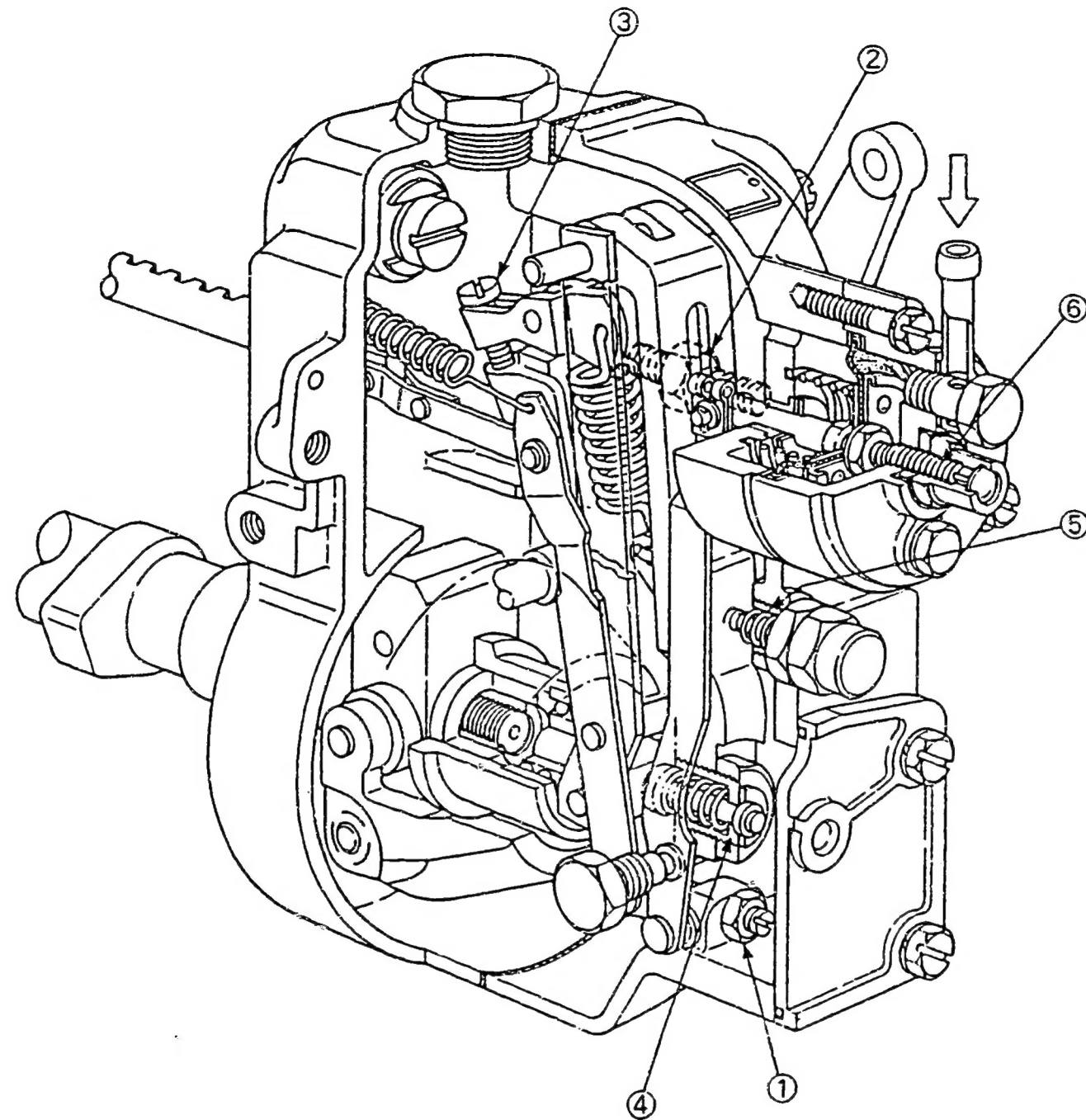

Figure 74

- 1 = Screw
- 2 = Screw
- 3 = Screw
- 4 = Spring capsule
- 5 = Spring capsule
- 6 = Screw

101692-3461 4/4

N 26

ZEXEL - Test values
Injection pumps



N 27

ZEXEL - Test values
Injection pumps

